



**Basic  
Technical Information  
For  
2013 Samsung  
Heat Pump  
Inverter Mini Splits**

**Quietside West  
8750 Pioneer Blvd  
Santa Fe Springs CA 90670  
Tel : 562 699 6066  
Fax : 562 699 4351**

**Quietside Central  
3001 Northern Cross Blvd.  
Suite #361  
Fort Worth, TX 76137  
Tel : 817 838 6066  
Fax : 817 838 8670**

**Quietside East  
6 Pine Hill Dr  
Carlisle PA 17013  
Tel : 717 243 2535  
Fax : 717 243 7917**

**Web : [www.quietside.com](http://www.quietside.com)**

**SAM-BT13-001**



## **CONTENTS**

<b>Page</b>	<b>Description</b>
3	AQV09NSD
4	AQV12NSD
5	AQV18NSD
6	AQV24NSD
7	AQV36JAN
8	AQV12VBE
9	AQV18VBE
10	AQV24VBE
11	AQN09VFUAGM
12	AQN12VFUAGM
13	AQN18VFUAGM
14	AQN24VFUAGM
15	AQN36VFUAGM
16	Max Wired Controller Option
17	MIM-A00A Supplemental Installation Instructions
18	MIM-A00A Supplemental Installation Instructions
19	EH035CAV
20	EH052CAV
21	EH070CAV
22	EH Model Series Rotary & Dip Switch Settings
23	DH105CAV
24	DH140CAV
25	DH Model Series Rotary & Dip Switch Settings
26	CH070CAV1
27	CH105CAV
28	CH140CAV
29	CH Model Series Rotary & Dip Switch Settings
30	MH050FXCA2A
31	MH080FXCA4A
32	MH026FNCA & MH035FNCA
33	MH052FNCA
34	MH026FECA & MH035FECA
35	MH052FECA
36	NJ030MHXCA & NJ035MHXCA
37	NJ052MHXCA
38	NJ0261HXCA & NJ0351HXCA
39	FJM (MH) Model Series Systems Auto Addressing
40	FJM (MH) Model Series Systems Manual Addressing
41	Installation Tips – Refrigeration

Due to Samsung's ongoing development policy specifications and information are subject to change without notice



## AQV09NSD Heat Pump Mini Split

Indoor Unit : **AQV09NSD**

Outdoor Unit : **AQV09NSDX**

### Power

Power Voltage :	208/230V – 1 Ph – 60 Hz
Control Voltage :	DDC Fuzzy Logic
Main Breaker Size :	15 A

### Line Sizes :

“Liquid” (expanded gas) line	1/4”
Suction	3/8”

**BOTH LINES MUST BE INSULATED SEPARATELY**

### Interconnect Length

Maximum / Minimum Length	50 / 10 feet
Vertical lift	26 feet

(Note condenser can be above or below evaporator)

### Charging

Unit is charged for	Maximum line set length (Factory Charge 31.7oz R410A)
Additional Charge of R410A	None required

### Charge for Line Run lengths

Length	25	30	35	40	45	50
Added Charge (oz)	0	0	0	0	0	0

### Interconnecting Wiring

Gauge	14 AWG Power & 16 AWG Shielded Communication
Number of Interconnecting Wires	3x14 AWG Power & 2x16 AWG Control = 5 Total

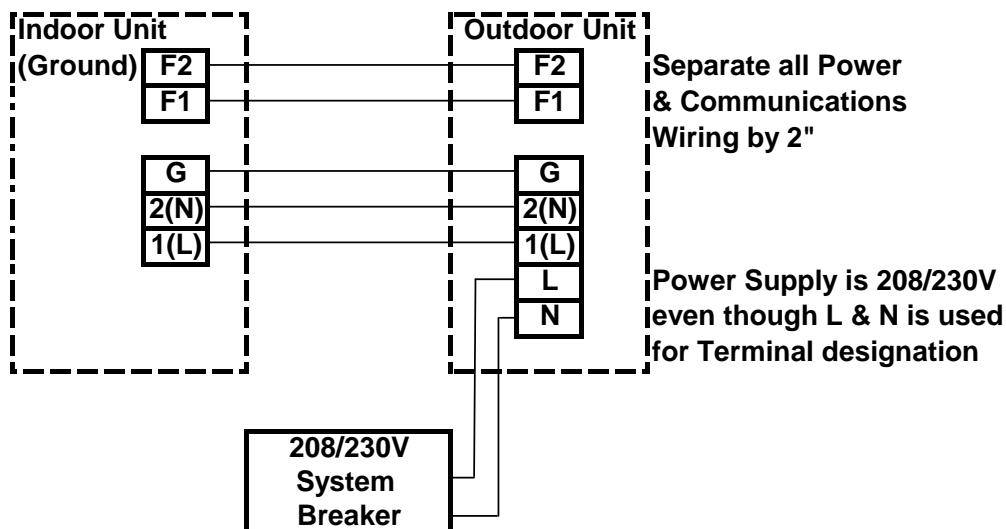



## AQV12NSD Heat Pump Mini Split

Indoor Unit : **AQV12NSD**

Outdoor Unit : **AQV12NSDX**

### Power

Power Voltage :	208/230V – 1 Ph – 60 Hz
Control Voltage :	DDC Fuzzy Logic
Main Breaker Size :	15 A

### Line Sizes :

“Liquid” (expanded gas) line	1/4”
Suction	3/8”

**BOTH LINES MUST BE INSULATED SEPARATELY**

### Interconnect Length

Maximum / Minimum Length	50 / 10 feet
Vertical lift	26 feet

(Note condenser can be above or below evaporator)

### Charging

Unit is charged for	Maximum Line set length (Factory Charge 31.7oz R410A)
Additional Charge of R410A	None required

### Charge for Line Run lengths

Length	25	30	35	40	45	50
Added Charge (oz)	0	0	0	0	0	0

### Interconnecting Wiring

Gauge	14 AWG Power & 16 AWG Shielded Communication
Number of Interconnecting Wires	3x14 AWG Power & 2x16 AWG Control = 5 Total

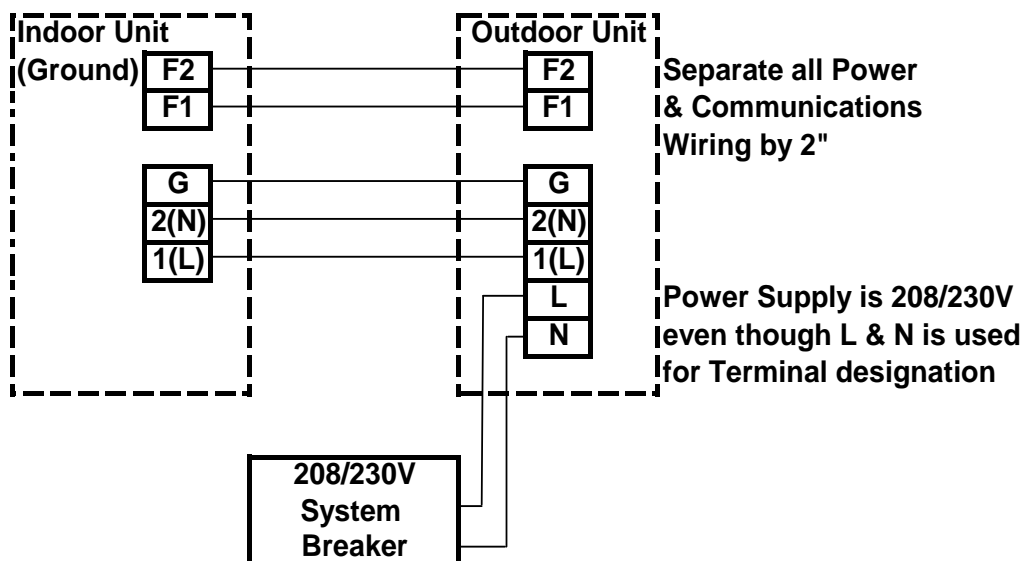



## AQV18NSD Heat Pump Mini Split

Indoor Unit : **AQV18NSD**

Outdoor Unit : **AQV18NSDX**

### Power

Power Voltage :	208/230V – 1 Ph – 60 Hz
Control Voltage :	DDC Fuzzy Logic
Main Breaker Size :	20 A

### Line Sizes :

“Liquid” (expanded gas) line	1/4”
Suction	1/2”

**BOTH LINES MUST BE INSULATED SEPARATELY**

### Interconnect Length

Maximum / Minimum Length	98 / 10 feet
Vertical lift	49 feet (Trap required at 26ft)

(Note condenser can be above or below evaporator)

### Charging

Unit is charged for	25 ft (Factory Charge 51.1oz R410A)
Additional Charge of R410A	0.15oz per ft over 25ft

### Charge for Line Run lengths

Length	25	35	45	55	65	75	85	95	98
Added Charge (oz)	0	1.5	3.0	4.5	6.0	7.5	9.0	10.5	10.95

### Interconnecting Wiring

Gauge	14 AWG Power & 16 AWG Shielded Communication
Number of Interconnecting Wires	3x14 AWG Power & 2x16 AWG Control = 5 Total

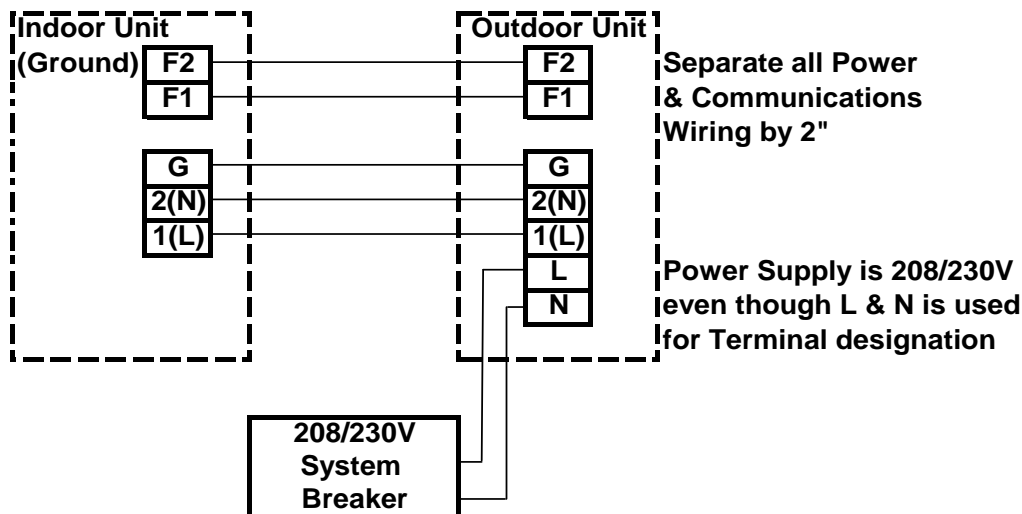



## AQV24NSD Heat Pump Mini Split

Indoor Unit : **AQV24NSD**

Outdoor Unit : **AQV24NSDX**

### Power

Power Voltage :	208/230V – 1 Ph – 60 Hz
Control Voltage :	DDC Fuzzy Logic
Main Breaker Size :	25 A

### Line Sizes :

“Liquid” (expanded gas) line	1/4”
Suction	5/8”

**BOTH LINES MUST BE INSULATED SEPARATELY**

### Interconnect Length

Maximum / Minimum Length	98 / 10 feet
Vertical lift	49 feet (Trap required at 26ft)

(Note condenser can be above or below evaporator)

### Charging

Unit is charged for	25 ft (Factory Charge 51.1oz R410A)
Additional Charge of R410A	0.15oz/ft over 25ft

### Charge for Line Run lengths

Length	25	35	45	55	65	75	85	95	98
Added Charge (oz)	0	1.5	3.0	4.5	6.0	7.5	9.0	10.5	10.95

### Interconnecting Wiring

Gauge	14 AWG Power & 16 AWG Shielded Communication
Number of Interconnecting Wires	3x14 AWG Power & 2x16 AWG Control = 5 Total

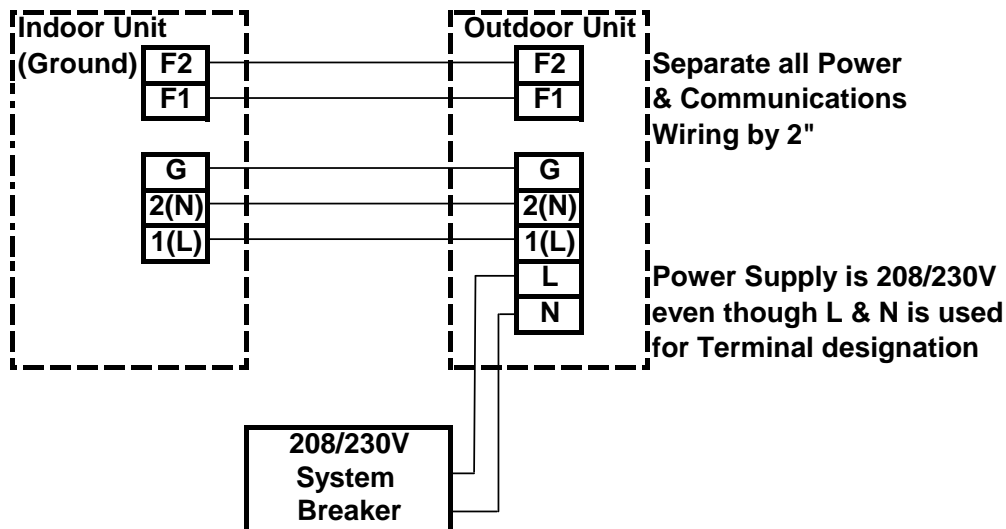



## AQV36JAN Heat Pump Mini Split

Indoor Unit : **AQV36JAN**

Outdoor Unit : **AQV36JAX**

### Power

Power Voltage :	208/230V – 1 Ph – 60 Hz
Control Voltage :	DDC Fuzzy Logic
Main Breaker Size :	35 A

### Line Sizes :

“Liquid” (expanded gas) line	1/4”
Suction	5/8”

**BOTH LINES MUST BE INSULATED SEPARATELY**

### Interconnect Length

Maximum / Minimum Length	165 / 10 feet
Vertical lift	98 feet (Trap required at 50ft)

(Note condenser can be above or below evaporator)

### Charging

Unit is charged for	25 ft (Factory Charge 88.1oz R410A)
Additional Charge of R410A	0.35oz/ft over 25ft

### Charge for Line Run lengths

Length	25	45	65	75	95	110	125	140	160
Added Charge (oz)	0	7	14	17.5	24.5	29.75	35	40.25	47.25

### Interconnecting Wiring

Gauge	14 AWG Power & 16 AWG Shielded Communication
Number of Interconnecting Wires	3x14 AWG Power & 2x16 AWG Control = 5 Total

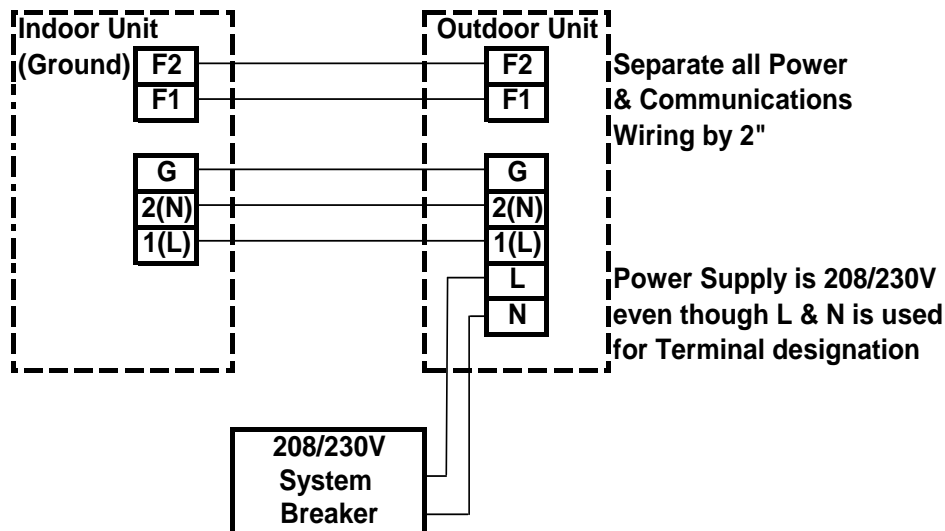



## AQV12VBE Vivace Heat Pump Mini Split

Indoor Unit : **AQV12VBE**

Outdoor Unit : **AQV12VBEX**

### Power

Power Voltage :	208/230V – 1 Ph – 60 Hz
Control Voltage :	DDC Fuzzy Logic
Main Breaker Size :	15 A

### Line Sizes :

“Liquid” (expanded gas) line	1/4”
Suction	3/8”

**BOTH LINES MUST BE INSULATED SEPARATELY**

### Interconnect Length

Maximum / Minimum Length	50 /10 feet
Vertical lift	26 feet

(Note condenser can be above or below evaporator)

### Charging

Unit is charged for	Maximum Line set length (Factory Charge 31.7oz R410A)
Additional Charge of R410A	None required

### Charge for Line Run lengths

Length	25	30	35	40	45	50
Added Charge (oz)	0	0	0	0	0	0

### Interconnecting Wiring

Gauge	14 AWG Power & 16 AWG Shielded Communication
Number of Interconnecting Wires	3x14 AWG Power & 2x16 AWG Control = 5 Total

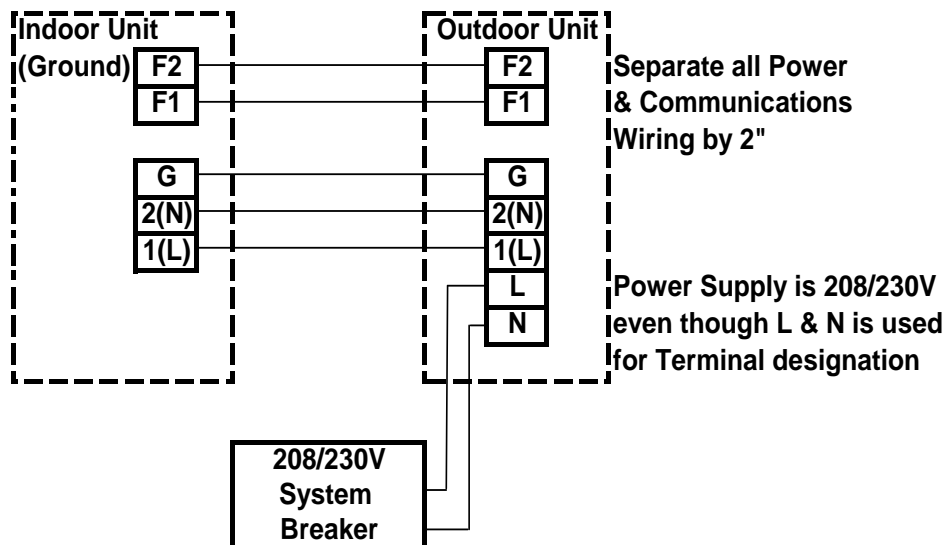





## **AQV18VBE Vivace Heat Pump Mini Split**

Indoor Unit : **AQV18VBE**

Outdoor Unit : **AQV18VBEX**

### **Power**

Power Voltage :	208/230V – 1 Ph – 60 Hz
Control Voltage :	DDC Fuzzy Logic
Main Breaker Size :	20 A

### **Line Sizes :**

“Liquid” (expanded gas) line	1/4”
Suction	1/2”

**BOTH LINES MUST BE INSULATED SEPARATELY**

### **Interconnect Length**

Maximum / Minimum Length	98 / 10 feet
Vertical lift	49 feet (Trap required at 26ft)

(Note condenser can be above or below evaporator)

### **Charging**

Unit is charged for	25 ft (Factory Charge 51.1oz R410A)
Additional Charge of R410A	0.15oz per ft over 25ft

### **Charge for Line Run lengths**

Length	25	35	45	55	65	75	85	95	98
Added Charge (oz)	0	1.5	3.0	4.5	6.0	7.5	9.0	10.5	10.95

### **Interconnecting Wiring**

Gauge	14 AWG Power & 16 AWG Shielded Communication
Number of Interconnecting Wires	3x14 AWG Power & 2x16 AWG Control = 5 Total

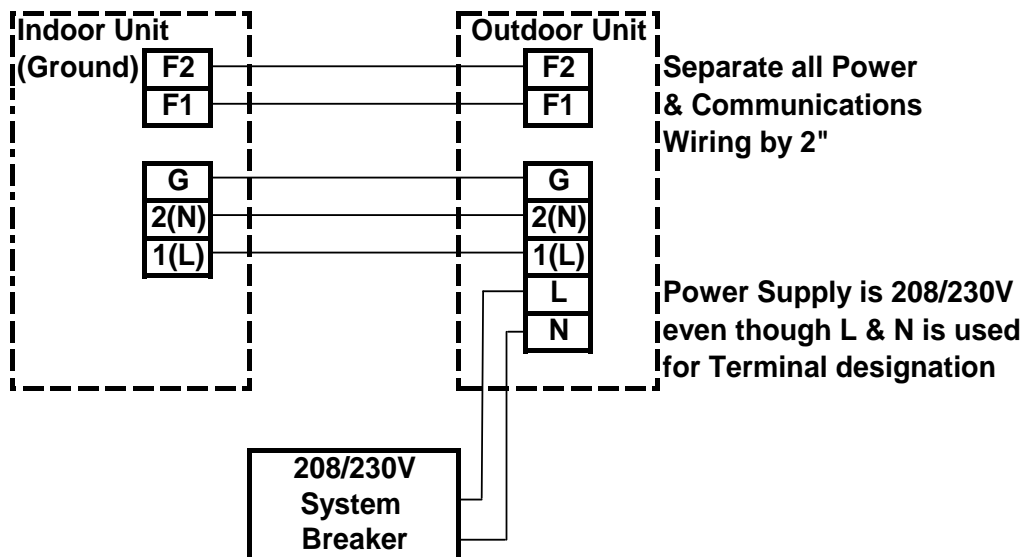



## AQV24VBE Vivace Heat Pump Mini Split

Indoor Unit : **AQV24VBE**

Outdoor Unit : **AQV24VBEX**

### Power

Power Voltage :	208/230V – 1 Ph – 60 Hz
Control Voltage :	DDC Fuzzy Logic
Main Breaker Size :	25 A

### Line Sizes :

“Liquid” (expanded gas) line	1/4”
Suction	5/8”

**BOTH LINES MUST BE INSULATED SEPARATELY**

### Interconnect Length

Maximum / Minimum Length	98 / 10 feet
Vertical lift	49 feet (Trap required at 26ft)

(Note condenser can be above or below evaporator)

### Charging

Unit is charged for	25 ft (Factory Charge 51.1oz R410A)
Additional Charge of R410A	0.15oz/ft over 25ft

### Charge for Line Run lengths

Length	25	35	45	55	65	75	85	95	98
Added Charge (oz)	0	1.5	3.0	4.5	6.0	7.5	9.0	10.5	10.95

### Interconnecting Wiring

Gauge	14 AWG Power & 16 AWG Shielded Communication
Number of Interconnecting Wires	3x14 AWG Power & 2x16 AWG Control = 5 Total

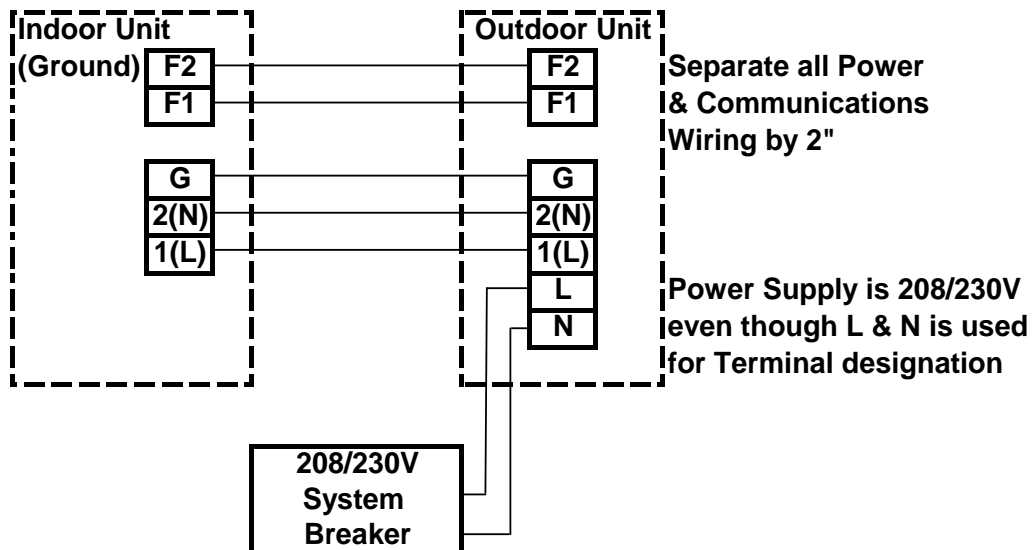



## AQN09VFUAGM Heat Pump Mini Split

Indoor Unit : **AQN09VFUAGM**

Outdoor Unit : **AQX09VFUAGN**

### Power

Power Voltage :	208/230V – 1 Ph – 60 Hz
Control Voltage :	DDC Fuzzy Logic
Main Breaker Size :	15 A

### Line Sizes :

“Liquid” (expanded gas) line	1/4”
Suction	3/8”

**BOTH LINES MUST BE INSULATED SEPARATELY**

### Interconnect Length

Maximum / Minimum Length	50 / 10 feet
Vertical lift	26 feet

(Note condenser can be above or below evaporator)

### Charging

Unit is charged for	25 ft (Factory Charge 31.7oz R410A)
Additional Charge of R410A	0.16oz/ft over 25ft

### Charge for Line Run lengths

Length	25	35	45	50
Added Charge (oz)	0	1.6	3.3	4.0

### Interconnecting Wiring

Gauge	14 AWG Power & 16 AWG Shielded Communication
Number of Interconnecting Wires	3x14 AWG Power & 2x16 AWG Control = 5 Total

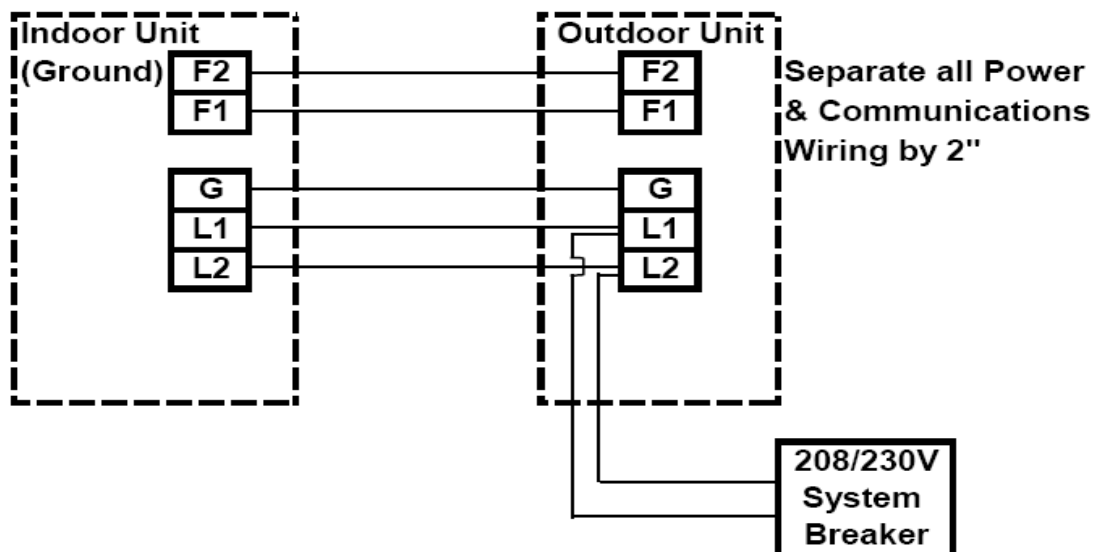



## AQN12VFUAGM Heat Pump Mini Split

Indoor Unit : **AQN12VFUAGM**

Outdoor Unit : **AQX12VFUAGM**

### Power

Power Voltage :	208/230V – 1 Ph – 60 Hz
Control Voltage :	DDC Fuzzy Logic
Main Breaker Size :	15 A

### Line Sizes :

“Liquid” (expanded gas) line	1/4”
Suction	3/8”

**BOTH LINES MUST BE INSULATED SEPARATELY**

### Interconnect Length

Maximum / Minimum Length	50 / 10 feet
Vertical lift	26 feet

(Note condenser can be above or below evaporator)

### Charging

Unit is charged for	25 ft (Factory Charge 31.7oz R410A)
Additional Charge of R410A	0.16oz/ft over 25ft

### Charge for Line Run lengths

Length	25	35	45	50
Added Charge (oz)	0	1.6	3.3	4.0

### Interconnecting Wiring

Gauge	14 AWG Power & 16 AWG Shielded Communication
Number of Interconnecting Wires	3x14 AWG Power & 2x16 AWG Control = 5 Total

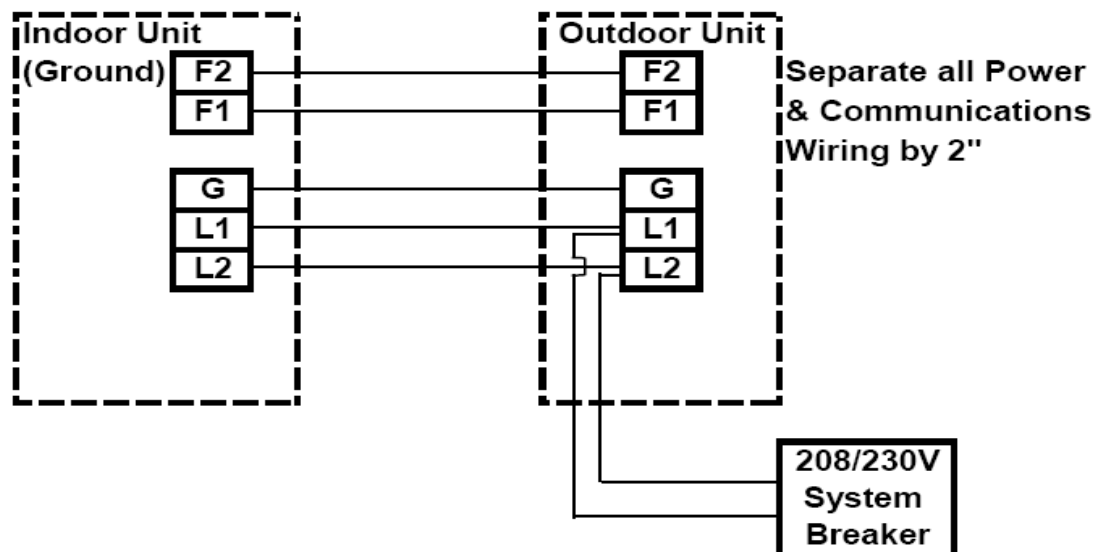



## AQN18VFUAGM Heat Pump Mini Split

Indoor Unit : **AQN18VFUAGM**

Outdoor Unit : **AQX18VFUAGM**

### Power

Power Voltage :	208/230V – 1 Ph – 60 Hz
Control Voltage :	DDC Fuzzy Logic
Main Breaker Size :	15 A

### Line Sizes :

“Liquid” (expanded gas) line	1/4”
Suction	1/2”

**BOTH LINES MUST BE INSULATED SEPARATELY**

### Interconnect Length

Maximum / Minimum Length	98 / 10 feet
Vertical lift	50 feet (Trap required at 26ft)

(Note condenser can be above or below evaporator)

### Charging

Unit is charged for	25 ft (Factory Charge 45.8oz R410A)
Additional Charge of R410A	0.16oz/ft over 25ft

### Charge for Line Run lengths

Length	25	35	45	55	65	75	85	95	98
Added Charge (oz)	0	1.6	3.2	4.8	6.4	8.0	9.6	11.2	11.68

### Interconnecting Wiring

Gauge	14 AWG Power & 16 AWG Shielded Communication
Number of Interconnecting Wires	3x14 AWG Power & 2x16 AWG Control = 5 Total

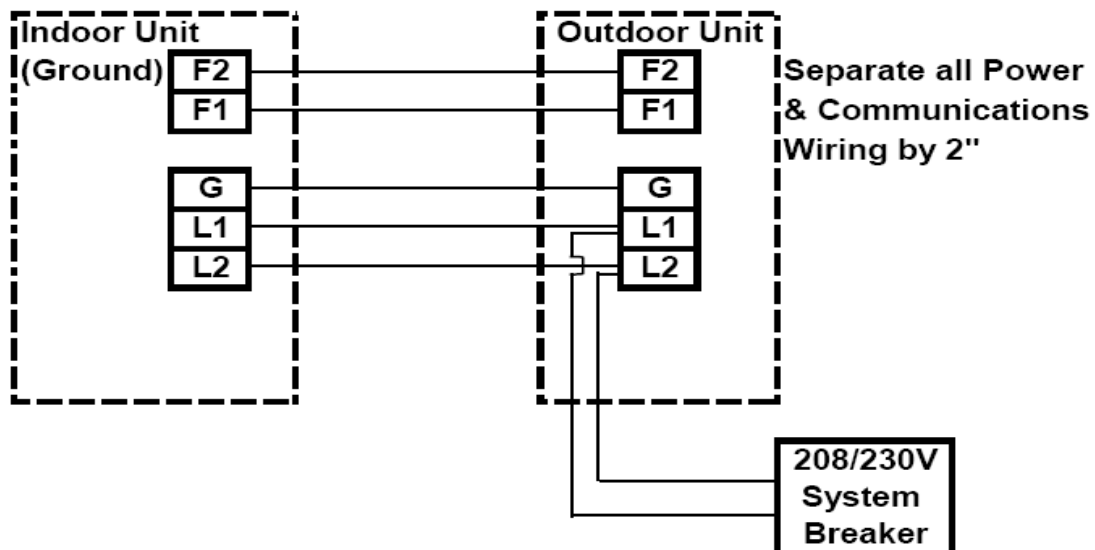



## AQN24VFUAGM Heat Pump Mini Split

Indoor Unit : **AQN24VFUAGM**

Outdoor Unit : **AQX24VFUAGM**

### Power

Power Voltage :	208/230V – 1 Ph – 60 Hz
Control Voltage :	DDC Fuzzy Logic
Main Breaker Size :	20 A

### Line Sizes :

“Liquid” (expanded gas) line	1/4”
Suction	5/8”

**BOTH LINES MUST BE INSULATED SEPARATELY**

### Interconnect Length

Maximum / Minimum Length	98 /10 feet
Vertical lift	50 feet (Trap required at 26ft)

(Note condenser can be above or below evaporator)

### Charging

Unit is charged for	25 ft (Factory Charge 58.1oz R410A)
Additional Charge of R410A	0.16oz/ft over 25ft

### Charge for Line Run lengths

Length	25	35	45	55	65	75	85	95	98
Added Charge (oz)	0	1.6	3.2	4.8	6.4	8.0	9.6	11.2	11.68

### Interconnecting Wiring

Gauge	14 AWG Power &16 AWG Shielded Communication
Number of Interconnecting Wires	3x14 AWG Power & 2x16 AWG Control = 5 Total

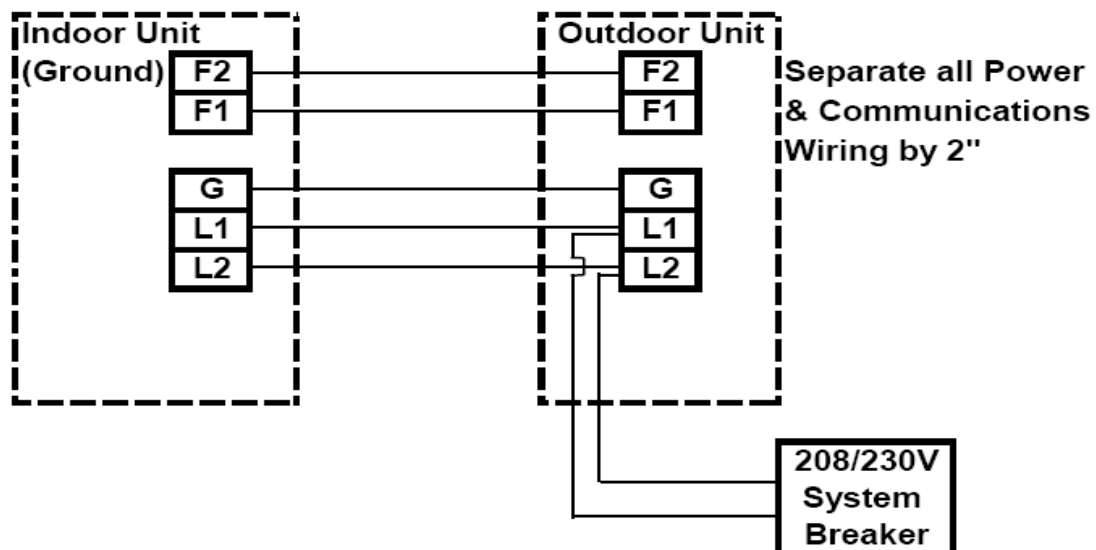



## AQN36VFUAGM Heat Pump Mini Split

Indoor Unit : **AQN36VFUAGM**

Outdoor Unit : **AQX36VFUAGM**

### Power

Power Voltage :	208/230V – 1 Ph – 60 Hz
Control Voltage :	DDC Fuzzy Logic
Main Breaker Size :	30 A

### Line Sizes :

“Liquid” (expanded gas) line	1/4”
Suction	5/8”

**BOTH LINES MUST BE INSULATED SEPARATELY**

### Interconnect Length

Maximum / Minimum Length	164 / 10 feet
Vertical lift	98 feet (Trap required at 26ft)

(Note condenser can be above or below evaporator)

### Charging

Unit is charged for	25 ft (Factory Charge 88.1oz R410A)
Additional Charge of R410A	0.43oz/ft over 25ft

### Charge for Line Run lengths

Length	25	35	45	55	65	75	85	95	100
Added Charge (oz)	0	4.3	8.6	12.9	17.2	21.5	25.8	30.1	32.25

### Interconnecting Wiring

Gauge	14 AWG Power & 16 AWG Shielded Communication
Number of Interconnecting Wires	3x14 AWG Power & 2x16 AWG Control = 5 Total

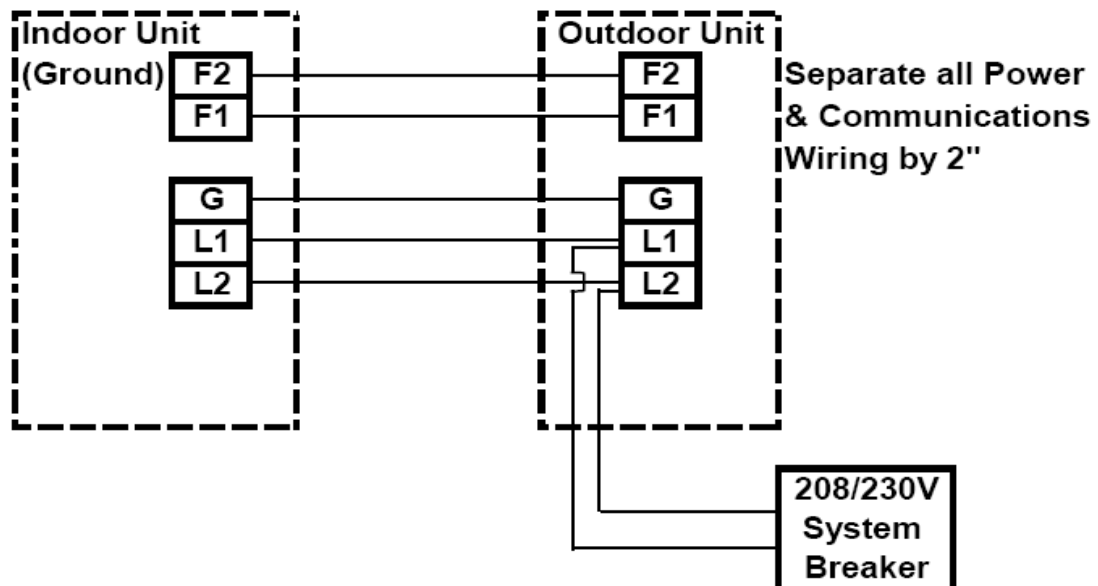



## **Max Wired Controller Option\*** **\*MIM-A00A Supplemental Installation Instructions**



Sub-PCB

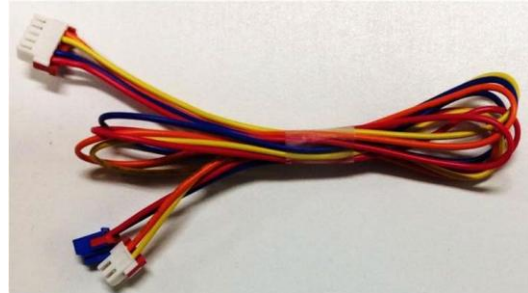

Sub-PCB Wire Harness

- The MIM-A00A sub-PCB installs inside a single MAX indoor unit (AQN\*\*VFUAGM models). It is required to connect and control an indoor unit with wired controller models MWR-WH00 or MWRWE10
- Provides 12V DC to Samsung wired controllers
- Required to control AQN\*\*VFUAGM models with Samsung central control options (upper level control)
- Includes sub-PCB, crimp wire connectors (4), wire harness, and sub-PCB cover

### **INSTALLATION NOTES:**

- Make sure power is turned off to the outdoor unit before opening the indoor unit PCB cover or cabinet.
- The front panel of the MAX indoor unit is easily removed to make installation easier and to prevent damage to the panel.

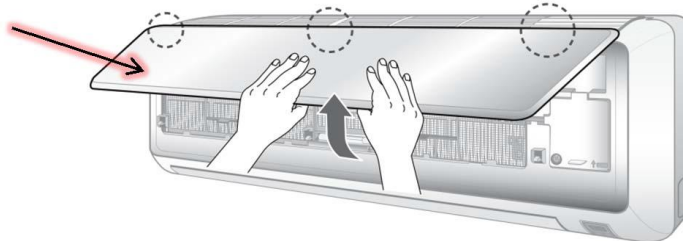

1. With the power off, open up the front panel of the MAX indoor unit. Remove the main PCB cover by removing the screw in the bottom corner.







## MIM-A00A Supplemental Installation Instructions

2. Inside the unit, towards the bottom of the cabinet you will find a PCB wire harness. Gently pull this wire upward and out of the unit



3. Plug the PCB wire harness into the sub-PCB (a) and the sub-PCB wire harness (b).

NOTE: the sub-PCB harness comes with the MIM-A00A (4 wires).

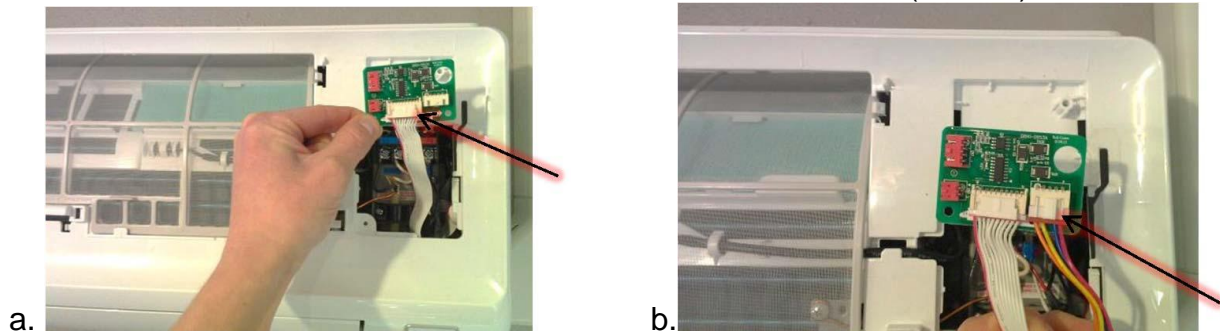

4. Remove protective tape (a) and slide all connected wires into the groove beside the sub-PCB mounting location (b). Snap the sub-PCB cover over the installed sub-PCB (c).

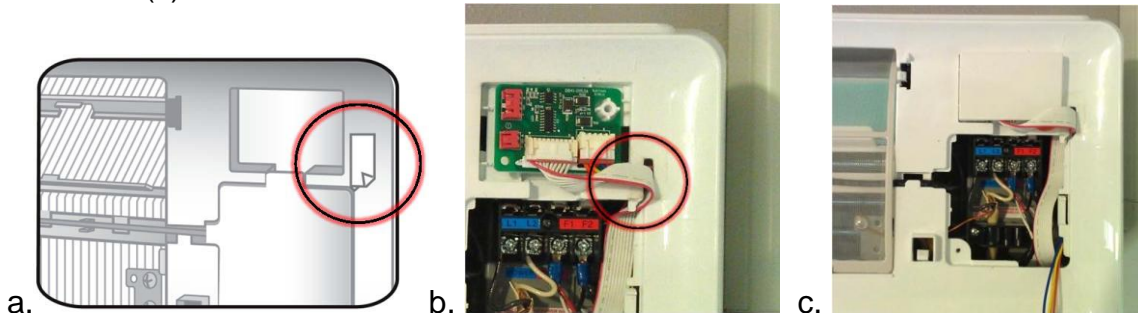

5. With the wired controller wires already installed, pull the wires through the front of the indoor unit. Cut the 2 small plastic connectors off the end of the sub-PCB wire harness (on the ends of the red/blue and yellow/orange wires). Connect F3 / F4 and V1 / V2 between the indoor unit and the wired controller as pictured on the diagram on the next page.



## MIM-A00A Supplemental Installation Instructions

Note: RED = F3, BLUE = F4, ORANGE= V1, YELLOW = V2

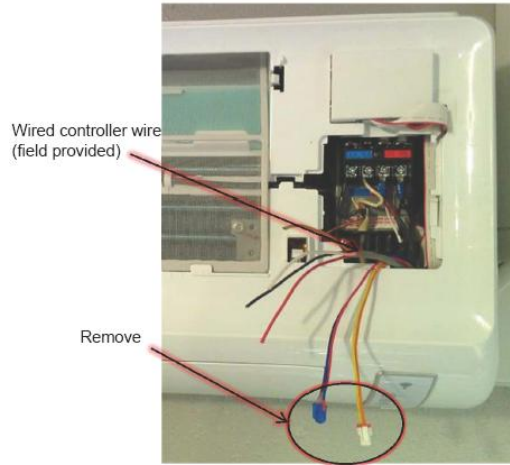

### Wire Diagram

NOTE: MWR-WH00 wired controllers ship with color coded connection wires (≈ 32').  
MWR-WE10 wired controllers do not include connection wire. This wire is field provided.

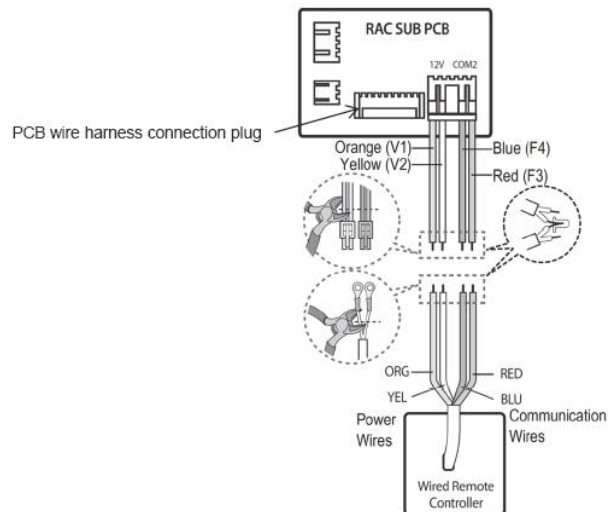

6. Tuck the connected wires into the unit cabinet and replace the main PCB cover and front panel (if removed). Apply power and setup wired controller (temperature sensing location, time, Fahrenheit, etc.).





## EH035CAV Slim Duct Heat Pump Mini Split

Indoor Unit : **EH035CAV**    Wired Remote : **MWR-TH01**    Outdoor Unit : **UH035CAV**

### Power

Power Voltage :	208/230V – 1 Ph – 60 Hz
Control Voltage :	DDC Fuzzy Logic
Main Breaker Size :	20 A

### Line Sizes :

“Liquid” (expanded gas) line	1/4”
Suction	3/8”

### **BOTH LINES MUST BE INSULATED SEPARATELY**

### Interconnect Length

Maximum / Minimum Length	65 / 10 feet
Vertical lift	23 feet

(Note condenser can be above or below evaporator)

### Charging

Unit is charged for	50ft (Factory Charge 35.3oz R410A)
Additional Charge of R410A	Add 0.15oz/ft when line set exceeds 50ft

### Charge for Line Run lengths

Length	25	30	35	40	45	50	55	60	65
Added Charge (oz)	0	0	0	0	0	0	0.75	1.5	2.25

### Interconnecting Wiring

Gauge	14 AWG Power & 16 AWG Shielded Communication
Number of Interconnecting Wires	3x14 AWG Power & 2x16 AWG Comms = 5 Total
Between unit and Wired RMC	4x16 AWG Control, 2 for 12V DC Power, 2 Comms

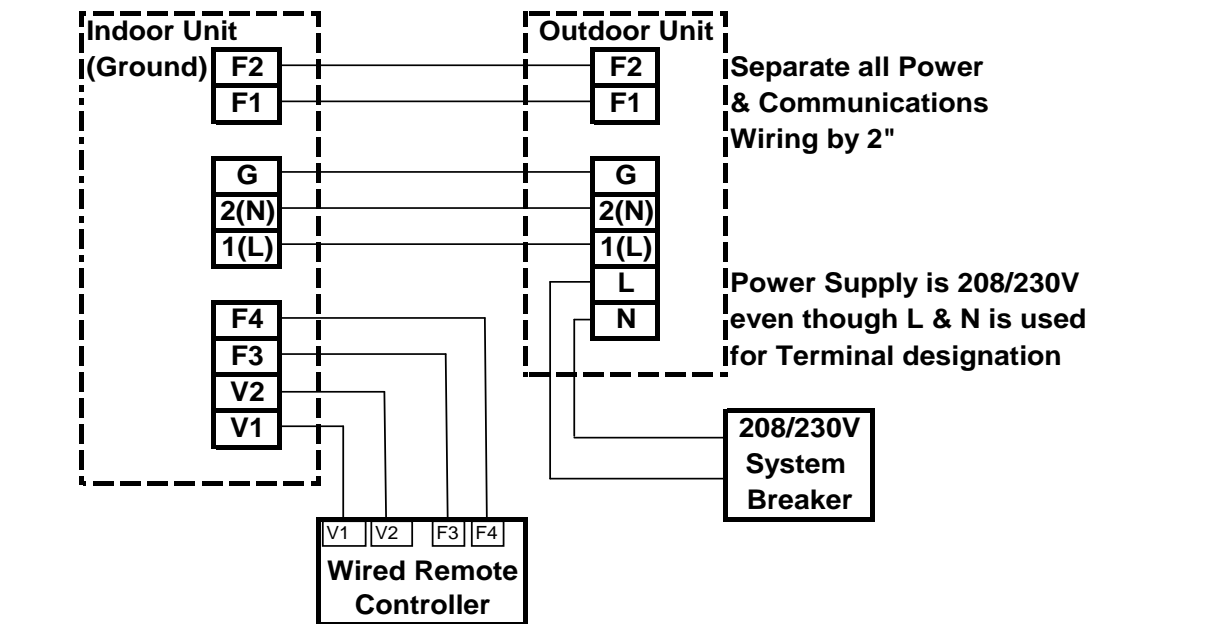



## **EH052CAV Slim Duct Heat Pump Mini Split**

Indoor Unit : **EH052CAV**    Wired Remote : **MWR-TH01**    Outdoor Unit : **UH052CAV**

### **Power**

Power Voltage :	208/230V – 1 Ph – 60 Hz
Control Voltage :	DDC Fuzzy Logic
Main Breaker Size :	25 A

### **Line Sizes :**

“Liquid” (expanded gas) line	1/4”
Suction	1/2”

**BOTH LINES MUST BE INSULATED SEPARATELY**

### **Interconnect Length**

Maximum / Minimum Length	98 / 10 feet
Vertical lift	49 feet (Trap required at 26ft)

(Note condenser can be above or below evaporator)

### **Charging**

Unit is charged for	25 ft (Factory Charge 51.1oz R410A)
Additional Charge of R410A	0.2oz per ft over 25ft

### **Charge for Line Run lengths**

Length	25	35	45	55	65	75	85	95	98
Added Charge (oz)	0	2.0	4.0	6.0	8.0	10.0	12.0	14.0	14.6

### **Interconnecting Wiring**

Gauge	14 AWG Power & 16 AWG Shielded Communication
Number of Interconnecting Wires	3x14 AWG Power & 2x16 AWG Comms = 5 Total
Between unit and Wired RMC	4x16 AWG Control, 2 for 12V DC Power, 2 Comms

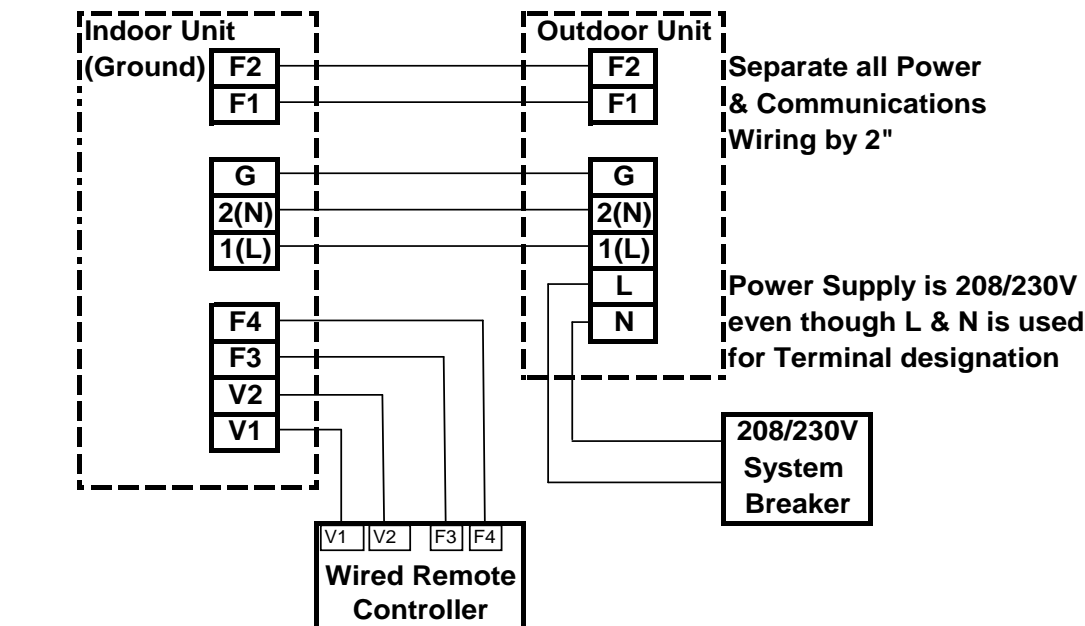



## **EH070CAV Slim Duct Heat Pump Mini Split**

Indoor Unit : **EH070CAV**    Wired Remote : **MWR-TH01**    Outdoor Unit : **UH070CAV**

### **Power**

Power Voltage :	208/230V – 1 Ph – 60 Hz
Control Voltage :	DDC Fuzzy Logic
Main Breaker Size :	30 A

### **Line Sizes :**

“Liquid” (expanded gas) line	1/4”
Suction	5/8”

**BOTH LINES MUST BE INSULATED SEPARATELY**

### **Interconnect Length**

Maximum / Minimum Length	98 / 10 feet
Vertical lift	49 feet (Trap required at 26ft)

(Note condenser can be above or below evaporator)

### **Charging**

Unit is charged for	25 ft (Factory Charge 67oz R410A)
Additional Charge of R410A	0.1oz per ft over 25ft

### **Charge for Line Run lengths**

Length	25	35	45	55	65	75	85	95	98
Added Charge (oz)	0	1.0	2.0	3.0	4.0	5.0	6.0	7.0	8.0

### **Interconnecting Wiring**

Gauge	14 AWG Power & 16 AWG Shielded Communication
Number of Interconnecting Wires	3x14 AWG Power & 2x16 AWG Comms = 5 Total
Between unit and Wired RMC	4x16 AWG Control, 2 for 12V DC Power, 2 Comms

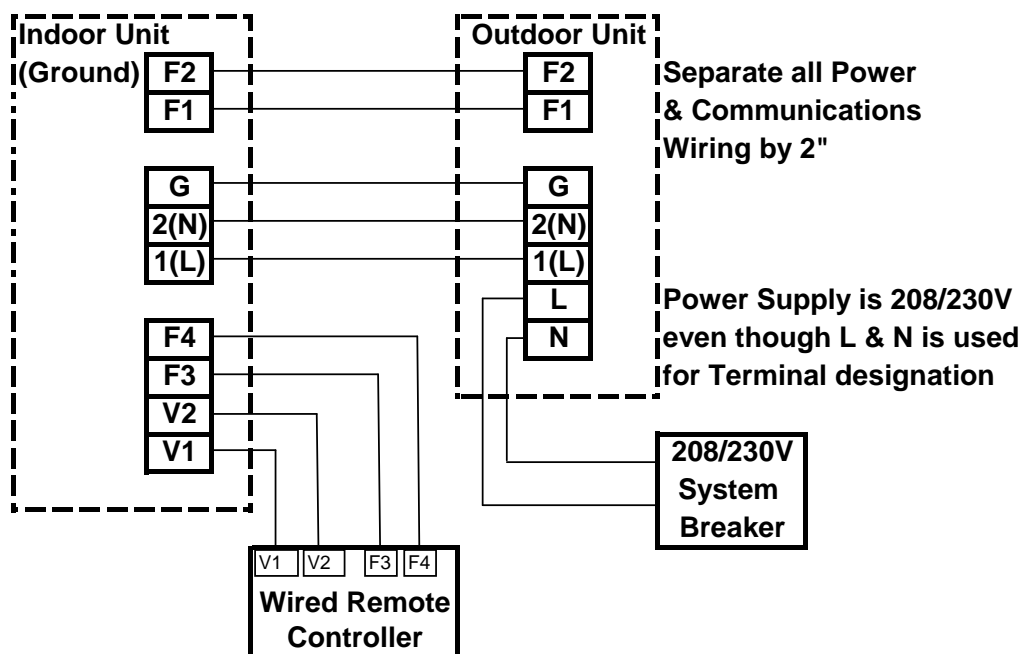



## EH Model Series Rotary Switch Settings

### Rotary Switch Settings

#### Indoor Unit

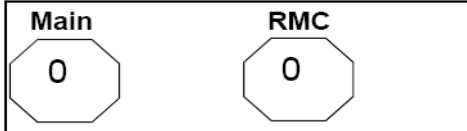

**Do not alter the factory default settings when using a Single Wired Remote Control to control only one Indoor/Outdoor unit**

Altering the RMC addresses in this application will result in ER 602 - Master/Slave being displayed on the Wired Remote Controller

#### Wired Remote Control

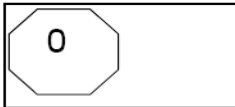

If controlling multiple Indoor units with one RMC contact Quietside Tech Support for a diagram

### Indoor unit Dip Switch Settings - EH Model Series

The correct setting of the Indoor PCB Dip Switches and the Dip Switches is required

Indoor Unit Dip Switches are all set in the ON position as the Factory Default

Depending on the application certain switches must be set to the OFF position to allow use of an option, or specific control feature

**USE OF THE WIRED REMOTE CONTROL IS STANDARD, THE #1 DIP SWITCH ON SW05 OF THE MAIN PCB OF THE INDOOR UNIT MUST BE SWITCHED TO THE OFF POSITION BEFORE STARTING THE UNIT**

Samsung recommend altering Dip switches prior to mounting the Indoor unit

Switch #'s read Left to Right, count to ensure the correct one is switched as they are all labeled 1-4

Indoor Unit				
	Switch#	Controls	Action	Setting
SW05	1	Use of Wired Remote	Switch to OFF if Wired Remote is used	OFF
	2	Central Control/SNET	Switch to OFF if Central/SNET option is used	ON
	3	Not used on this unit	Ignore	ON
	4	Condensate Pump	Switch to OFF if Samsung Pump is installed	ON
SW06	1	Temp Compensation	Switch to OFF to compensate for duct heat gain	ON
	2	Filter Timer Light	Switch to OFF to increase time for filter change	ON
	3	Hot Water Coil	Contact Factory to discuss auxiliary heat option	ON
	4	Not used on this unit	Ignore	ON
SW07	1	Not used on this unit	Ignore	ON
	2	Not used on this unit	Ignore	ON
	3	Remote On/Off control	Switch to OFF to allow external control of unit	ON
	4	Not used on this unit	Ignore	ON
MWR-TH01 Wired Remote Control				
	K1	Heat Pump/Cooling Only	Switch to ON for Heat Pump operation	ON
	K2	Use of F3/F4 or F1/F2	Switch to OFF as unit uses F3 - F4 Comms	OFF
	K3	Display DegC or DegF	Switch to ON for DegF Display	ON
	K4	Wired/Wireless Control	Switch to OFF to allow use of both controls	ON
	K5	Not used on this unit	Ignore	N/A
	K6	Not used on this unit	Ignore	N/A
	K7	Not used on this unit	Ignore	N/A
	K8	Not used on this unit	Ignore	N/A

After every Dip Switch change the power to the system must be turned off for 3 minutes to allow the unit to recognize the changes to the Dip Switch settings



## DH105CAV MSP Duct Heat Pump

Indoor Unit : **DH105CAV**    Wired Remote : **MWR-WE10**    Outdoor Unit : **UH105CAV**

### Power

Power Voltage :	208/230V – 1 Ph – 60 Hz
Control Voltage :	DDC Fuzzy Logic
Main Breaker Size :	35 A

### Line Sizes :

“Liquid” (expanded gas) line	3/8”
Suction	5/8”

**BOTH LINES MUST BE INSULATED SEPARATELY**

### Interconnect Length

Maximum / Minimum Length	246 / 10 feet
Vertical lift	98 feet (Trap required every 50ft)

(Note condenser can be above or below evaporator)

### Charging

Unit is charged for	25 ft (Factory Charge 98.8oz R410A)
Additional Charge of R410A	0.4oz per ft over 25ft

### Charge for Line Run lengths

Length	25	45	65	85	105	125	150	175	200
Added Charge (oz)	0	8.0	18.0	24.0	32.0	40.0	50.0	60.0	70.0

### Interconnecting Wiring

Gauge	14 AWG Power & 16 AWG Shielded Communication
Number of Interconnecting Wires	3x14 AWG Power & 2x16 AWG Coms = 5 Total
Between unit and Wired RMC	2 sets of 2x16 AWG Control, for 12VDC Power, Coms

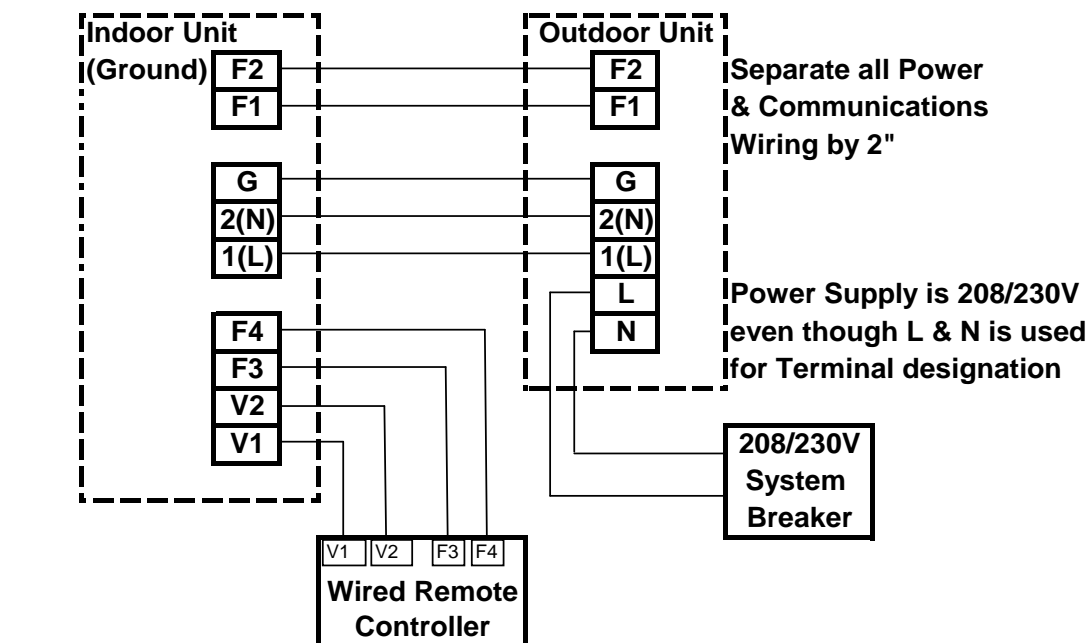



## DH140CAV MSP Duct Heat Pump

Indoor Unit : **DH140CAV**    Wired Remote : **MWR-WE10**    Outdoor Unit : **UH140CAV**

### Power

Power Voltage :	208/230V – 1 Ph – 60 Hz
Control Voltage :	DC Fuzzy Logic
Main Breaker Size :	50 A

### Line Sizes :

“Liquid” (expanded gas) line	3/8”
Suction	3/4”

**BOTH LINES MUST BE INSULATED SEPARATELY**

### Interconnect Length

Maximum / Minimum Length	246 /10 feet
Vertical lift	98 feet (Trap required at 26ft)

(Note condenser can be above or below evaporator)

### Charging

Unit is charged for	25 ft (Factory Charge 98.8oz R410A)
Additional Charge of R410A	0.4oz per ft over 25ft

### Charge for Line Run lengths

Length	25	45	65	85	105	125	150	175	200
Added Charge (oz)	0	8.0	18.0	24.0	32.0	40.0	50.0	60.0	70.0

### Interconnecting Wiring

Gauge	14 AWG Power & 16 AWG Shielded Communication
Number of Interconnecting Wires	3x14 AWG Power & 2x16 AWG Coms = 5 Total
Between unit and Wired RMC	2 sets of 2x16 AWG Control, for 12VDC Power, Coms

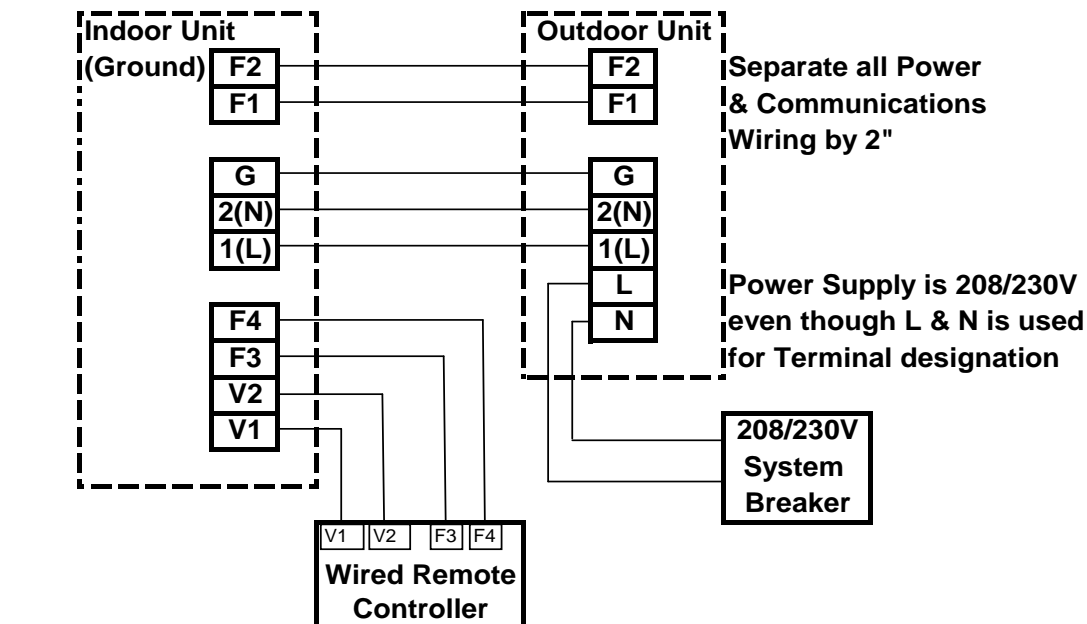





## DH Model Series Rotary Switch Settings

### Rotary Switch Settings

#### Indoor Unit

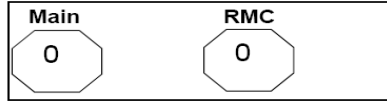

**Do not alter the factory default settings when using a Single Wired Remote Control to control only one Indoor/Outdoor unit**

Altering the RMC addresses in this application will result in ER 602 - Master/Slave being displayed on the Wired Remote Controller

If controlling multiple Indoor units with one RMC contact Quietside Tech Support for a diagram

### Indoor unit Dip Switch Settings - DH Model Series

The correct setting of the Indoor PCB Dip Switches and the Dip Switches is required

Indoor Unit Dip Switches are all set in the ON position as the Factory Default

Depending on the application certain switches must be set to the OFF position to allow use of an option, or specific control feature

**USE OF THE WIRED REMOTE CONTROL IS STANDARD, THE #1 DIP SWITCH ON SW05**

**OF THE MAIN PCB OF THE INDOOR UNIT MUST BE SWITCHED TO THE OFF POSITION BEFORE STARTING THE UNIT**

Samsung recommend altering Dip switches prior to mounting the Indoor unit

Switch #'s read Left to Right, count to ensure the correct one is switched as they are all labeled 1-4

Indoor Unit				
	Switch#	Controls	Action	Setting
SW05	1	Use of Wired Remote	Switch to OFF if Wired Remote is used	OFF
	2	Central Control/SNET	Switch to OFF if Central/SNET option is used	ON
	3	Not used on this unit	Ignore	ON
	4	Condensate Pump	Switch to OFF only if the optional Samsung Condensate Pump is installed and wired to PCB	ON
SW06	1	Temp Compensation	Switch to OFF to compensate for duct heat gain	ON
	2	Filter Timer Light	Switch to OFF to increase time for filter change	ON
	3	Hot Water Coil	Contact Factory to discuss auxiliary heat option	ON
	4	Not used on this unit	Ignore	ON
SW07	1	Not used on this unit	Ignore	ON
	2	Not used on this unit	Ignore	ON
	3	Remote On/Off control	Switch to OFF to allow external control of unit	ON
	4	Not used on this unit	Ignore	ON

#### E620 error on start up of MWR-WE10

"E620" indicates the wired controller has a different temperature unit setting than the indoor unit. The following steps will set the controller to degF and enable it to communicate with the indoor unit. Press and hold the "SET" and "ESC" buttons for at least 3 seconds. A flashing "1" will display (main menu)

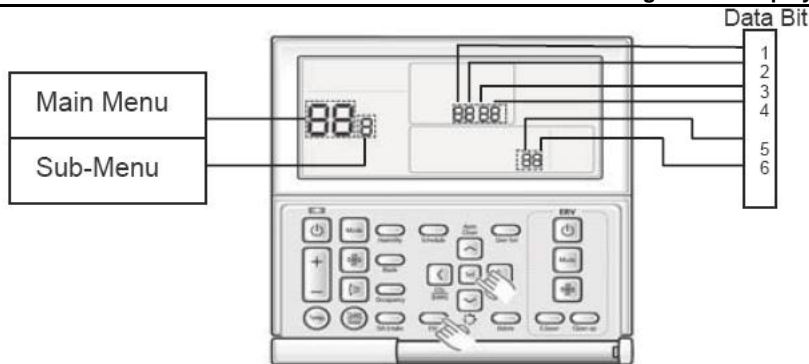

Press (>) button – another "1" will display & flash for the sub menu  
 Press (>) button again to display the 4 digit "data settings"  
 "0100" should be displayed for the "data settings"  
 Press the (>) until the 4th digit is flashing in the "data bit field".  
 Press the (v) button to change that digit to "1"  
 "0101" should now be displayed for "data setting"  
 Press the "SET" button, then press "ESC"



## CH070CAV1 Cassette Heat Pump

Indoor Unit : **CH070CAV1** Wired Remote : **MWR-WE10** Outdoor Unit : **UH070CAV1**

### Power

Power Voltage :	208/230V – 1 Ph – 60 Hz
Control Voltage :	DC Fuzzy Logic
Main Breaker Size :	25 A

### Line Sizes :

“Liquid” (expanded gas) line	1/4”
Suction	5/8”

**BOTH LINES MUST BE INSULATED SEPARATELY**

### Interconnect Length

Maximum / Minimum Length	162 / 10 feet
Vertical lift	98 feet (Trap required every 26ft)

(Note condenser can be above or below evaporator)

### Charging

Unit is charged for	25 ft (Factory Charge 67oz R410A)
Additional Charge of R410A	0.1oz per ft over 25ft

### Charge for Line Run lengths

Length	25	40	55	70	85	100	115	130	150
Added Charge (oz)	0	1.0	2.0	3.0	4.0	5.0	6.0	7.0	8.0

### Interconnecting Wiring

Gauge	14 AWG Power & 16 AWG Shielded Communication
Number of Interconnecting Wires	3x14 AWG Power & 2x16 AWG Comms = 5 Total
Between unit and Wired RMC	4x16 AWG Control, 2 for 12V DC Power, 2 Comms

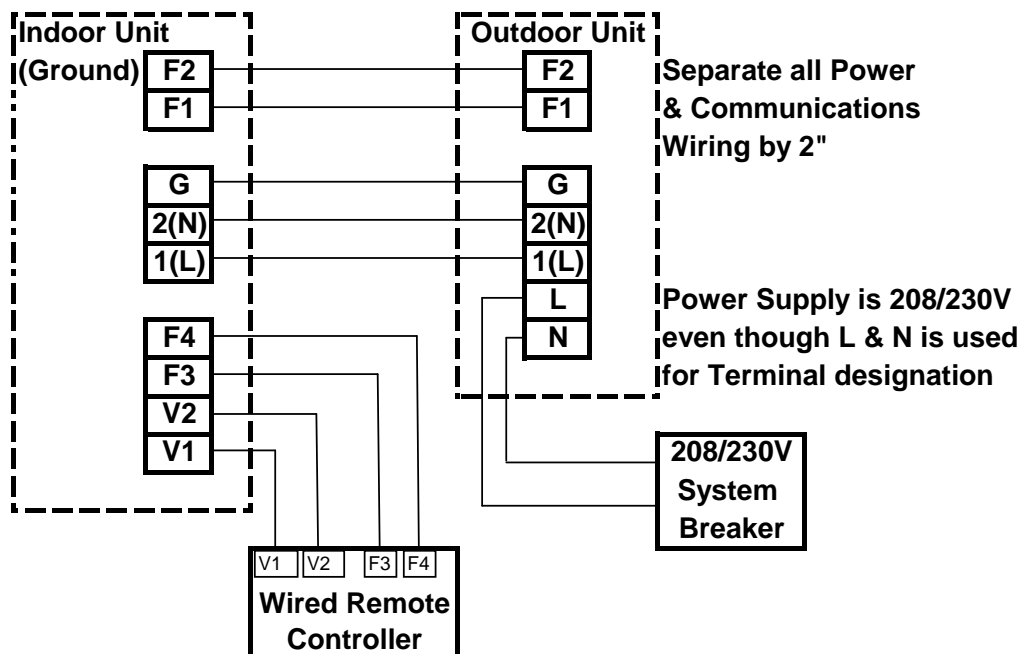



## CH105CAV Cassette Heat Pump

Indoor Unit : **CH105CAV**    Wired Remote : **MWR-WE10**    Outdoor Unit : **UH105CAV**

### Power

Power Voltage :	208/230V – 1 Ph – 60 Hz
Control Voltage :	DC Fuzzy Logic
Main Breaker Size :	35 A

### Line Sizes :

“Liquid” (expanded gas) line	3/8”
Suction	5/8”

**BOTH LINES MUST BE INSULATED SEPARATELY**

### Interconnect Length

Maximum / Minimum Length	246 / 10 feet
Vertical lift	98 feet (Trap required at 26ft)

(Note condenser can be above or below evaporator)

### Charging

Unit is charged for	25 ft (Factory Charge 98.8oz R410A)
Additional Charge of R410A	0.4oz per ft over 25ft

### Charge for Line Run lengths

Length	25	45	65	85	105	125	150	175	200
Added Charge (oz)	0	8.0	18.0	24.0	32.0	40.0	50.0	60.0	70.0

### Interconnecting Wiring

Gauge	14 AWG Power & 16 AWG Shielded Communication
Number of Interconnecting Wires	3x14 AWG Power & 2x16 AWG Coms = 5 Total
Between unit and Wired RMC	2 sets of 2x16 AWG Control, for 12VDC Power, Coms

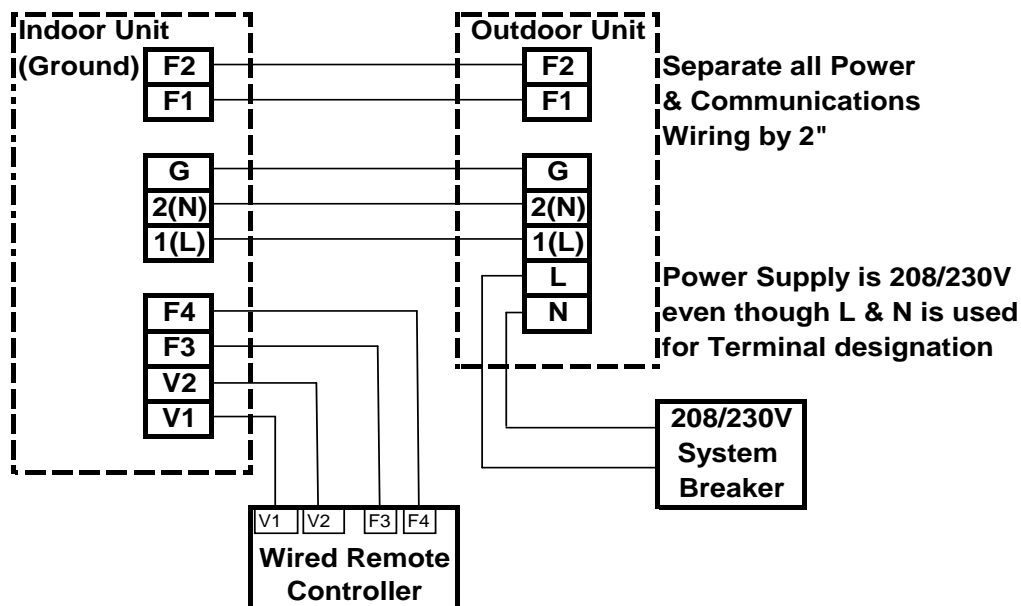



## CH140CAV Cassette Heat Pump

Indoor Unit : **DH140CAV**    Wired Remote : **MWR-WE10**    Outdoor Unit : **UH105CAV**

### Power

Power Voltage :	208/230V – 1 Ph – 60 Hz
Control Voltage :	DC Fuzzy Logic
Main Breaker Size :	50 A

### Line Sizes :

"Liquid" (expanded gas) line	3/8"
Suction	3/4"

**BOTH LINES MUST BE INSULATED SEPARATELY**

### Interconnect Length

Maximum / Minimum Length	246 / 10 feet
Vertical lift	98 feet (Trap required at 26ft)

(Note condenser can be above or below evaporator)

### Charging

Unit is charged for	25 ft (Factory Charge 98.8oz R410A)
Additional Charge of R410A	0.4oz per ft over 25ft

### Charge for Line Run lengths

Length	25	45	65	85	105	125	150	175	200
Added Charge (oz)	0	8.0	18.0	24.0	32.0	40.0	50.0	60.0	70.0

### Interconnecting Wiring

Gauge	14 AWG Power & 16 AWG Shielded Communication
Number of Interconnecting Wires	3x14 AWG Power & 2x16 AWG Coms = 5 Total
Between unit and Wired RMC	2 sets of 2x16 AWG Control, for 12VDC Power, Coms

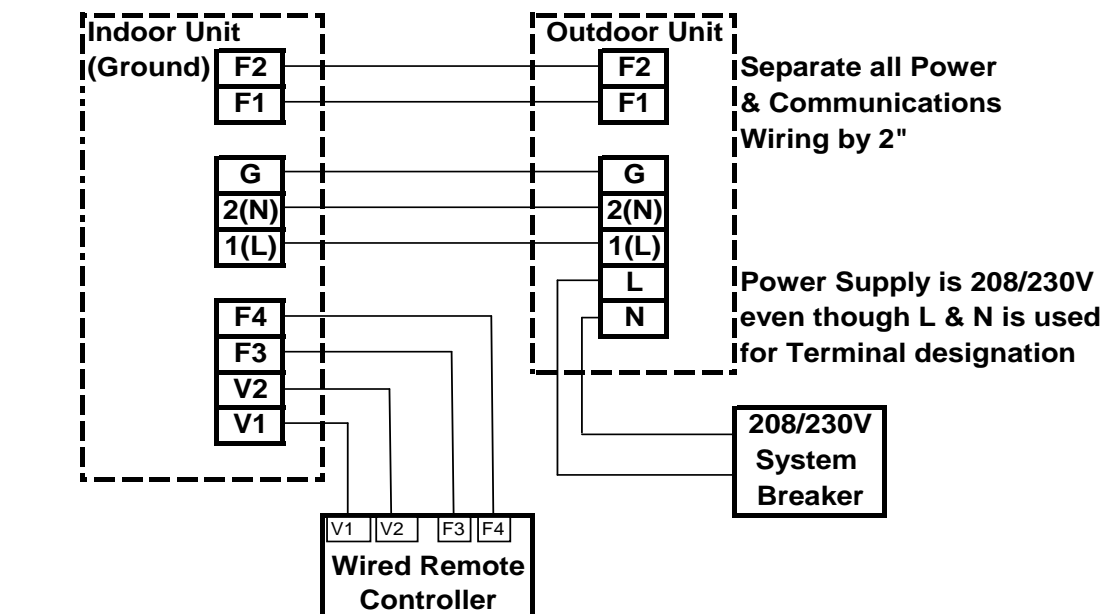



## CH Model Series Rotary Switch Settings

### Rotary Switch Settings

#### Indoor Unit

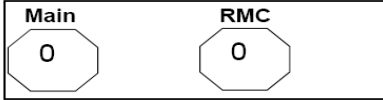

**Do not alter the factory default settings when using a Single Wired Remote Control to control only one Indoor/Outdoor unit**

Altering the RMC addresses in this application will result in ER 602 - Master/Slave being displayed on the Wired Remote Controller

If controlling multiple Indoor units with one RMC contact Quietside Tech Support for a diagram

### Indoor unit Dip Switch Settings - DH Model Series

The correct setting of the Indoor PCB Dip Switches and the Dip Switches is required

Indoor Unit Dip Switches are all set in the ON position as the Factory Default

Depending on the application certain switches must be set to the OFF position to allow use of an option, or specific control feature

**USE OF THE WIRED REMOTE CONTROL IS STANDARD, THE #1 DIP SWITCH ON SW05**

**OF THE MAIN PCB OF THE INDOOR UNIT MUST BE SWITCHED TO THE OFF POSITION BEFORE STARTING THE UNIT**

Samsung recommend altering Dip switches prior to mounting the Indoor unit

Switch #'s read Left to Right, count to ensure the correct one is switched as they are all labeled 1-4

Indoor Unit				
	Switch#	Controls	Action	Setting
SW05	1	Use of Wired Remote	Switch to OFF if Wired Remote is used	OFF
	2	Central Control/SNET	Switch to OFF if Central/SNET option is used	ON
	3	Not used on this unit	Ignore	ON
	4	Condensate Pump	Ignore - Condensate Pump is standard on CH Units	N/A
SW06	1	Temp Compensation	Switch to OFF to compensate for duct heat gain	ON
	2	Filter Timer Light	Switch to OFF to increase time for filter change	ON
	3	Not used on this unit	Ignore	ON
	4	Not used on this unit	Ignore	ON
SW07	1	Minimum EEV Step	Switch to OFF to close EEV completely in off cycle	ON
	2	Master/Slave	Switch to OFF to designate Master	ON
	3	Remote On/Off control	Switch to OFF to allow external control of unit	ON
	4	Not used on this unit	Ignore	N/A

#### E620 error on start up of MWR-WE10

"E620" indicates the wired controller has a different temperature unit setting than the indoor unit. The following steps will set the controller to degF and enable it to communicate with the indoor unit. Press and hold the "SET" and "ESC" buttons for at least 3 seconds. A flashing "1" will display (main menu)

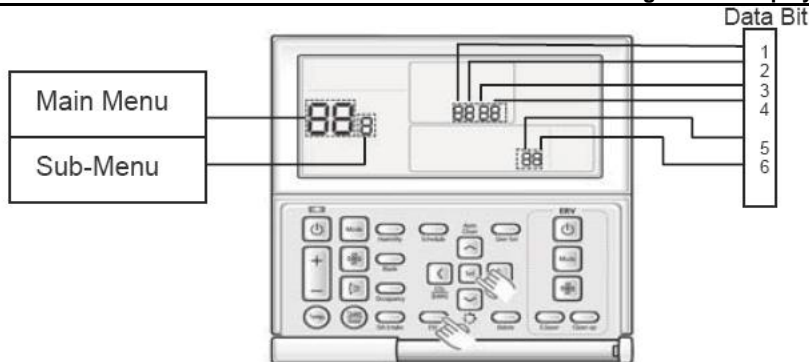

Press (>) button – another "1" will display & flash for the sub menu  
 Press (>) button again to display the 4 digit "data settings"  
 "0100" should be displayed for the "data settings"  
 Press the (>) until the 4th digit is flashing in the "data bit field".  
 Press the (v) button to change that digit to "1"  
 "0101" should now be displayed for "data setting"  
 Press the "SET" button, then press "ESC"



# MH050FXCA2A Dual Zone Heat Pump Outdoor Unit

Matching Indoor units: MH026FNCA, MH026FECA, MH035FNCA & MH035FECA

### Power

Power Voltage :	208/230V – 1 Ph – 60 Hz
Control Voltage :	DC Fuzzy Logic
Main Breaker Size :	25 A

### Line Sizes :

“Liquid” (expanded gas) line	1/4”
Suction	3/8”

**ALL LINES MUST BE INSULATED SEPARATELY**

### Interconnect Length

Maximum Combined Length	100 feet
Maximum / Minimum Individual Length	75 / 10 feet
Vertical lift	49 feet (Trap required at 26ft)

(Note condenser can be above or below evaporator)

### Charging

Unit is charged for	65 ft (Factory Charge 70.55oz R410A)
Additional Charge of R410A	0.11oz/ft over 65ft

### Charge for Combined Line Run lengths

Length	25	35	45	55	65	75	85	95	100
Added Charge (oz)	0	0	0	0	0	1.1	2.2	3.3	3.9

### Interconnecting Wiring

Gauge	14 AWG Power, <b>1(L), 2(N)</b> & 16 AWG Shielded Communication, <b>F1, F2</b>
Number of Interconnecting Wires	3x14 AWG Power & 2x16 AWG Control = 5 Total

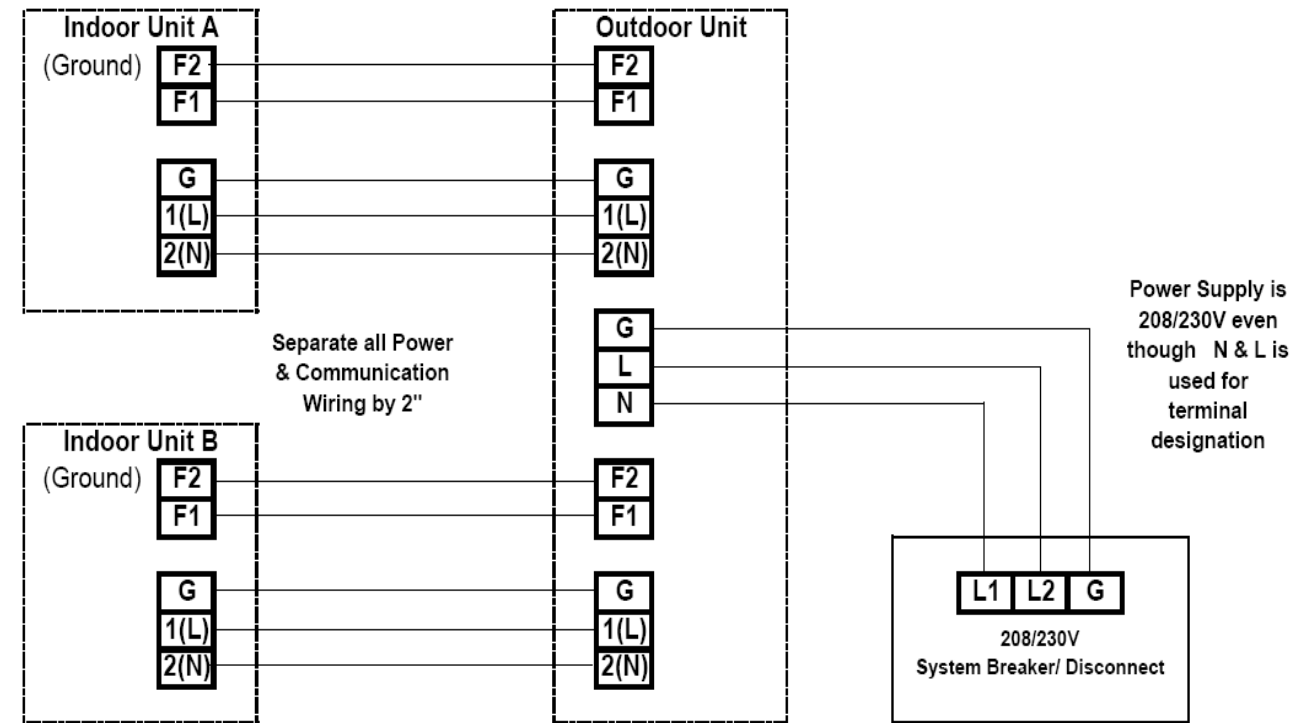



# MH080FXCA4A Quad Zone Heat Pump Outdoor Unit

Matching Indoor units: MH026FNCA, MH026FECA, MH035FNCA, MH035FECA  
 MH052FNCA & MH052FECA

### Power

Power Voltage :	208/230V – 1 Ph – 60 Hz
Control Voltage :	DC Fuzzy Logic
Main Breaker Size :	25 A

### Line Sizes :

"Liquid" (expanded gas) line	1/4"
Suction	(MH026 & MH035) 3/8" (MH052) 1/2"

**ALL LINES MUST BE INSULATED SEPARATELY**

### Interconnect Length

Maximum Combined Length	225 feet
Maximum / Minimum Individual Length	75 / 10 feet
Vertical lift	98 feet (Trap required at 26ft)

(Note condenser can be above or below evaporator)

### Charging

Unit is charged for	131 ft (Factory Charge 98.77oz R410A)
Additional Charge of R410A	0.11oz/ft over 131ft

### Charge for Combined Line Run lengths

Length	25	45	65	85	105	131	150	175	200
Added Charge (oz)	0	0	0	0	0	0	2.1	4.8	5.6

### Interconnecting Wiring

Gauge	14 AWG Power, 1(L), 2(N) & 16 AWG Shielded Communication, F1, F2
Number of Interconnecting Wires	3x14 AWG Power & 2x16 AWG Control = 5 Total

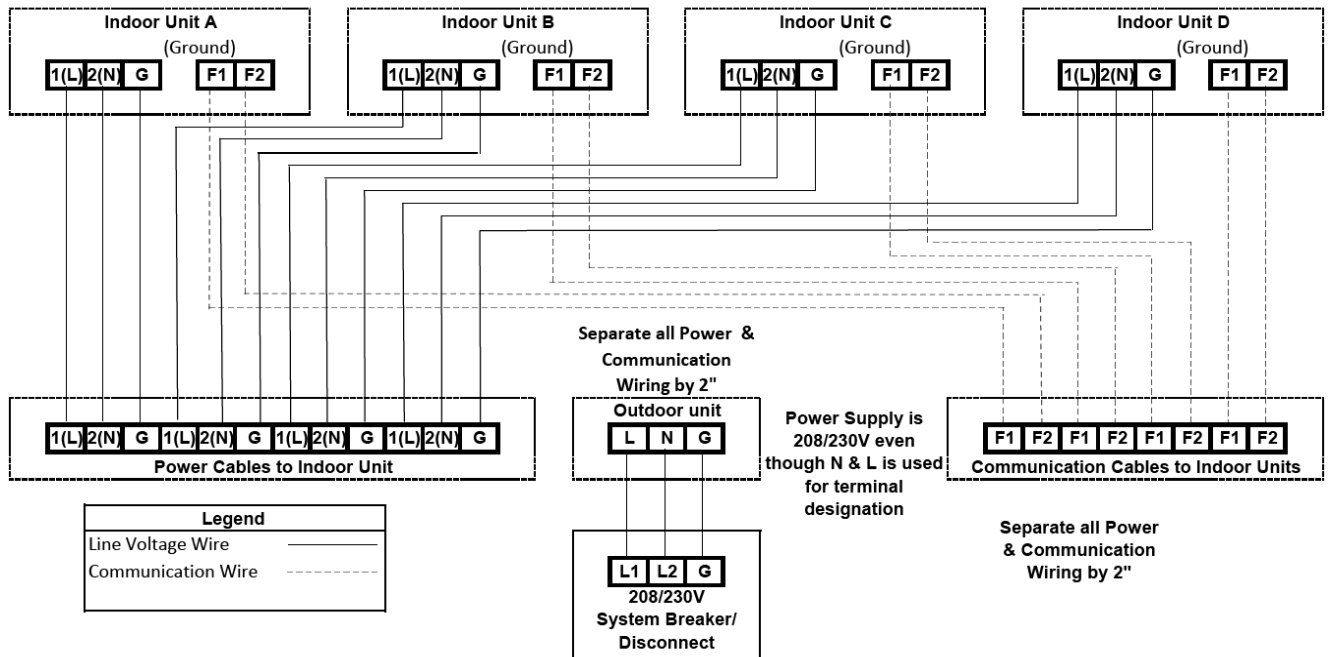



## **MH026FNCA & MH035FNCA Multi Zone Neo Forte Heat Pump High Wall Indoor Units**

Matching Outdoor units: MH050FXCA2A & MH080FXCA4A

### **Power**

Power Voltage :	208/230V – 1 Ph – 60 Hz
Control Voltage :	DC Fuzzy Logic
Main Breaker Size :	No Dedicated Circuit Indoor Unit is Powered by the Outdoor Unit

### **Line Sizes :**

“Liquid” (expanded gas) line	1/4”
Suction	3/8”

**ALL LINES MUST BE INSULATED SEPARATELY**

### **Interconnect Length**

Maximum Combined Length	Depends on match
Maximum / Minimum Individual Length	75 / 10 feet
Vertical lift	Depends on match (Trap required at 26ft)

(Note evaporator can be above or below condenser)

### **Charging**

Unit is charged for	Nitrogen Holding Charge Only
Additional Charge of R410A	See Outdoor Unit

### **Interconnecting Wiring**

Gauge	14 AWG Power, <b>1(L), 2(N)</b> & 16 AWG Shielded Communication, <b>F1, F2</b>
Number of Interconnecting Wires	3x14 AWG Power & 2x16 AWG Control = 5 Total

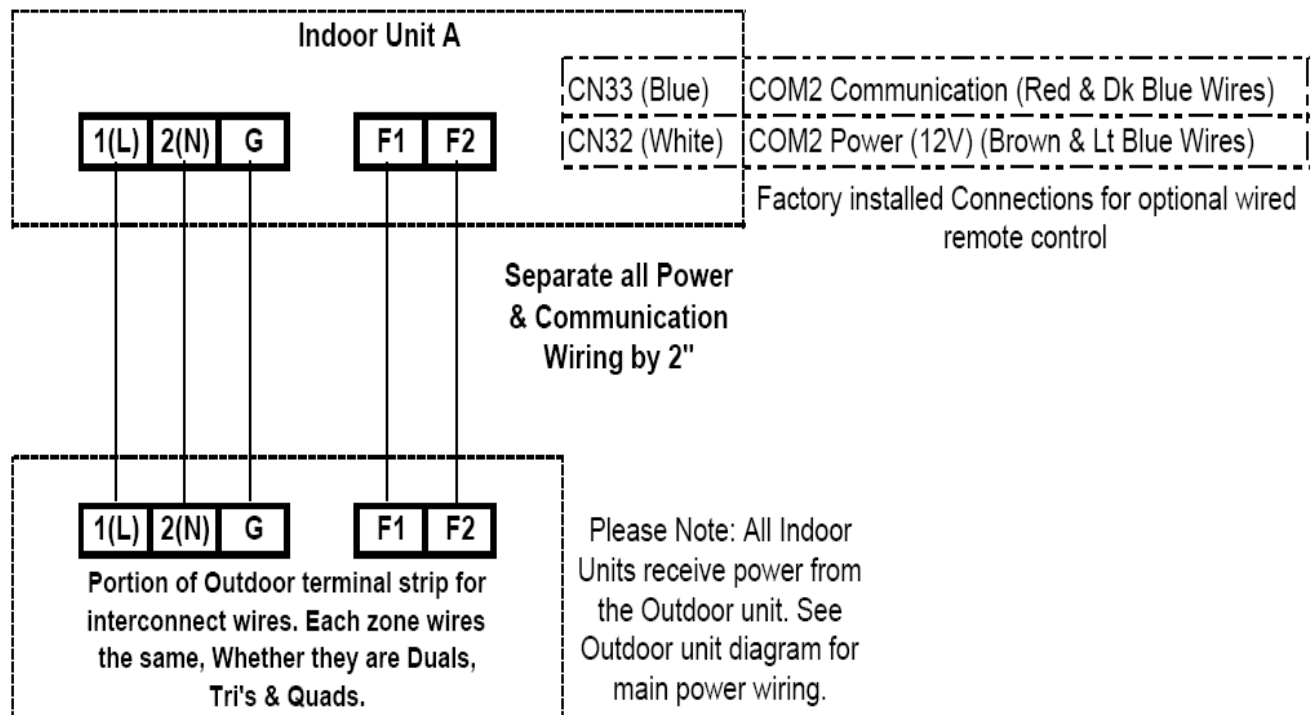





## **MH052FNCA Multi Zone Heat Pump Neo Forte High Wall Indoor Unit**

Matching Outdoor unit: MH080FXCA4A

### **Power**

Power Voltage :	208/230V – 1 Ph – 60 Hz
Control Voltage :	DC Fuzzy Logic
Main Breaker Size :	No Dedicated Circuit Indoor Unit is Powered by the Outdoor Unit

### **Line Sizes :**

“Liquid” (expanded gas) line	1/4”
Suction	1/2”

**ALL LINES MUST BE INSULATED SEPARATELY**

### **Interconnect Length**

Maximum Combined Length	Depends on match
Maximum / Minimum Individual Length	75 / 10 feet
Vertical lift	Depends on match (Trap required at 26ft)

(Note evaporator can be above or below condenser)

### **Charging**

Unit is charged for	Nitrogen Holding Charge Only
Additional Charge of R410A	See Outdoor Unit

### **Interconnecting Wiring**

Gauge	14 AWG Power, <b>1(L), 2(N)</b> & 16 AWG Shielded Communication, <b>F1, F2</b>
Number of Interconnecting Wires	3x14 AWG Power & 2x16 AWG Control = 5 Total

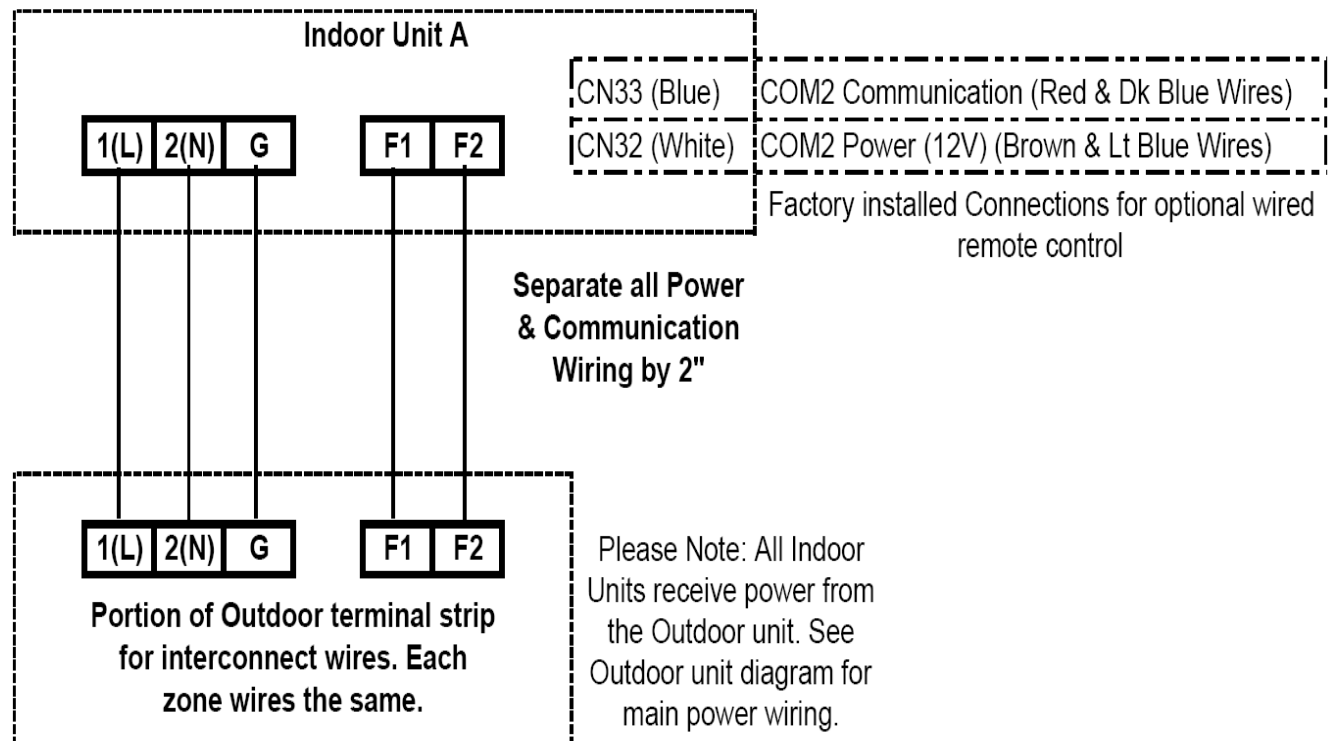



## **MH026FECA & MH035FECA Multi Zone Slim Duct Heat Pump Indoor Units**

Matching Outdoor units: MH050FXCA2A & MH080FXCA4A

### **Power**

Power Voltage :	208/230V – 1 Ph – 60 Hz
Control Voltage :	DDC Fuzzy Logic
Main Breaker Size :	No Dedicated Circuit Indoor Unit is Powered by the Outdoor Unit

### **Line Sizes :**

"Liquid" (expanded gas) line	1/4"
Suction	3/8"

**ALL LINES MUST BE INSULATED SEPARATELY**

### **Interconnect Length**

Maximum Combined Length	Depends on match
Maximum / Minimum Individual Length	75 / 10feet
Vertical lift	Depends on match (Trap required at 26ft)

(Note evaporator can be above or below condenser)

### **Charging**

Unit is charged for	Nitrogen Holding Charge Only
Additional Charge of R410A	See Outdoor Unit

### **Interconnecting Wiring**

Gauge	14 AWG Power, <b>1(L), 2(N)</b> & 16 AWG Shielded Communication, <b>F1, F2</b>
Number of Interconnecting Wires	3x14 AWG Power & 2x16 AWG Control = 5 Total

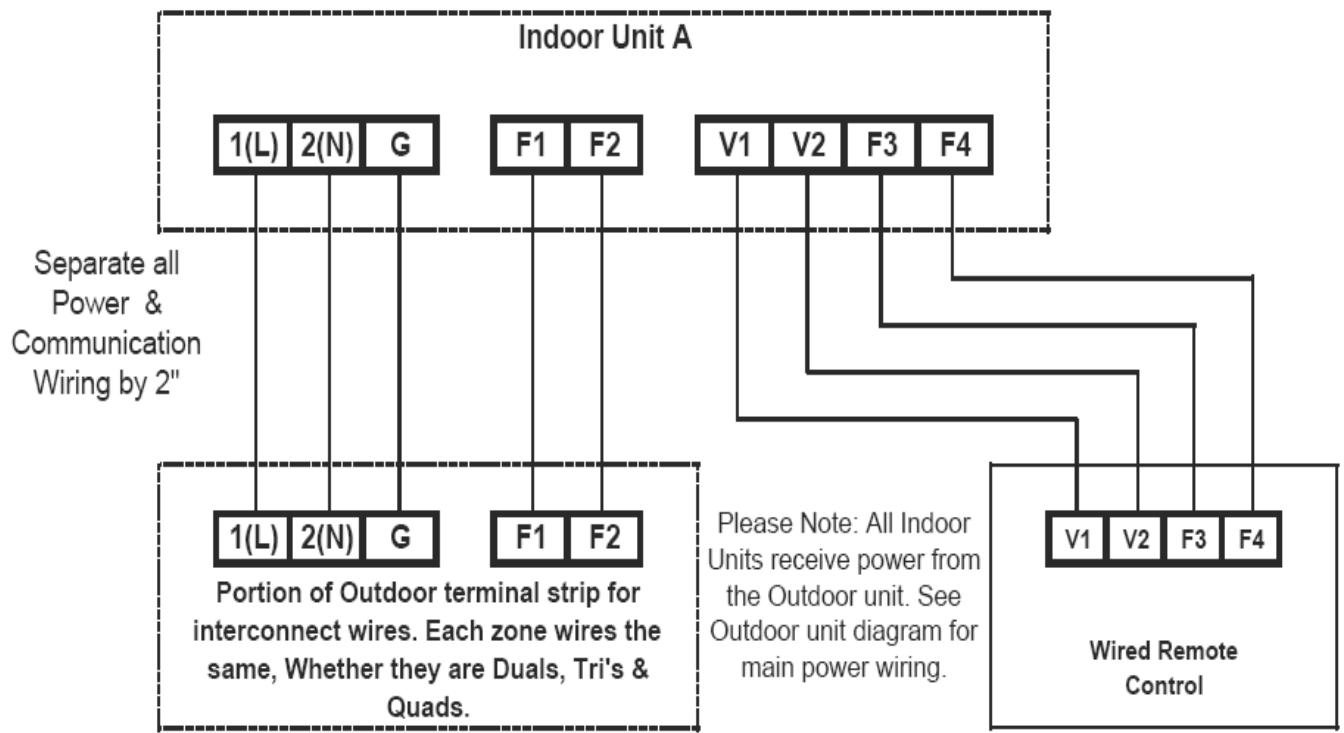



## **MH052FECA Multi Multi Zone Slim Duct Heat Pump Indoor Units**

Matching Outdoor unit: MH080FXCA4A

### Power

Power Voltage :	208/230V – 1 Ph – 60 Hz
Control Voltage :	DDC Fuzzy Logic
Main Breaker Size :	No Dedicated Circuit Indoor Unit is Powered by the Outdoor Unit

### Line Sizes :

“Liquid” (expanded gas) line	1/4”
Suction	1/2”

**ALL LINES MUST BE INSULATED SEPARATELY**

### Interconnect Length

Maximum Combined Length	Depends on match
Maximum / Minimum Individual Length	75 /10feet
Vertical lift	Depends on match (Trap required at 26ft)

(Note evaporator can be above or below condenser)

### Charging

Unit is charged for	Nitrogen Holding Charge Only
Additional Charge of R410A	See Outdoor Unit

### Interconnecting Wiring

Gauge	14 AWG Power, <b>1(L), 2(N)</b> & 16 AWG Shielded Communication, <b>F1, F2</b>
Number of Interconnecting Wires	3x14 AWG Power & 2x16 AWG Control = 5 Total

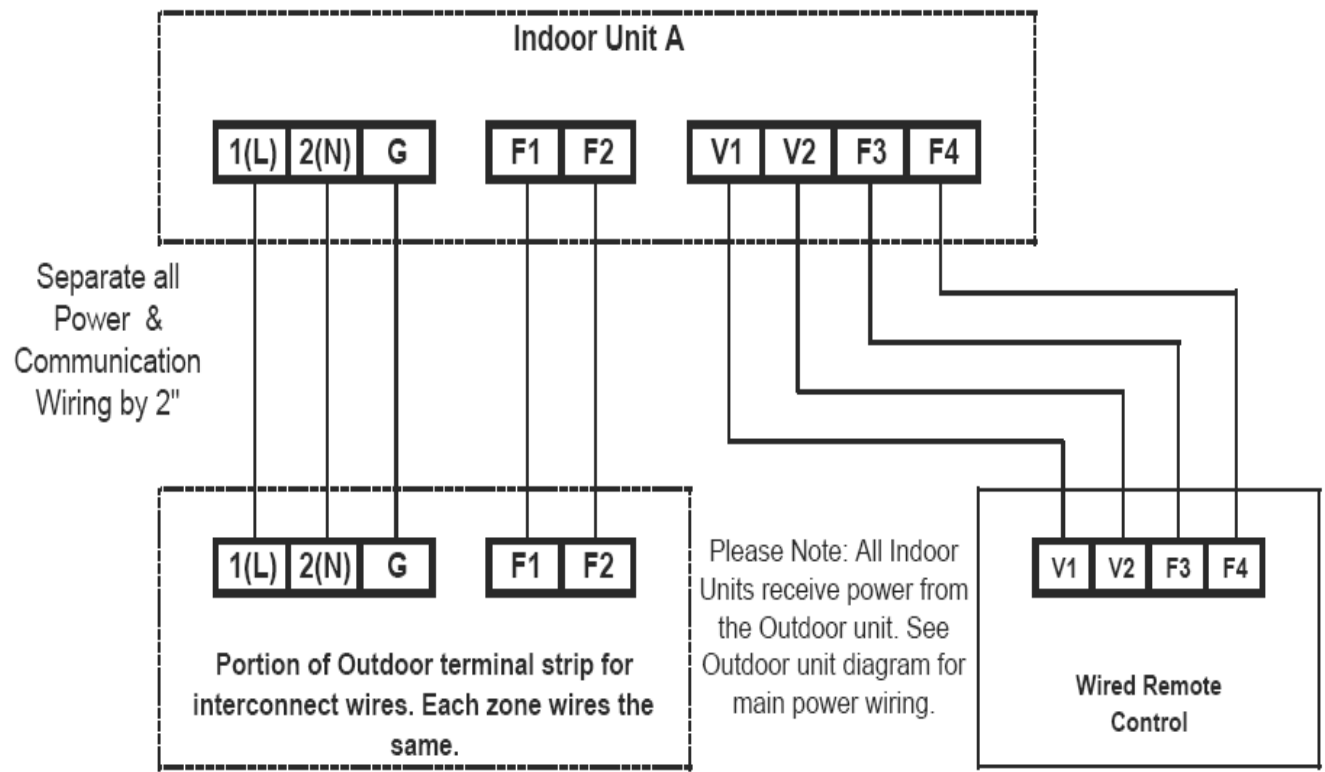



## **NJ030MHXCA & NJ035MHXCA Multi Zone Mini 4 Way Cassette Heat Pump Indoor Units**

Matching Outdoor units: MH050FXCA2A & MH080FXCA4A

### **Power**

Power Voltage :	208/230V – 1 Ph – 60 Hz
Control Voltage :	DDC Fuzzy Logic
Main Breaker Size :	No Dedicated Circuit Indoor Unit is Powered by the Outdoor Unit

### **Line Sizes :**

“Liquid” (expanded gas) line	1/4”
Suction	3/8”

**ALL LINES MUST BE INSULATED SEPARATELY**

### **Interconnect Length**

Maximum Combined Length	Depends on match
Maximum / Minimum Individual Length	75 / 10 feet
Vertical lift	Depends on match (Trap required at 26ft)

(Note evaporator can be above or below condenser)

### **Charging**

Unit is charged for	Nitrogen Holding Charge Only
Additional Charge of R410A	See Outdoor Unit

### **Interconnecting Wiring**

Gauge	14 AWG Power, <b>1(L), 2(N)</b> & 16 AWG Shielded Communication, <b>F1, F2</b>
Number of Interconnecting Wires	3x14 AWG Power & 2x16 AWG Control = 5 Total

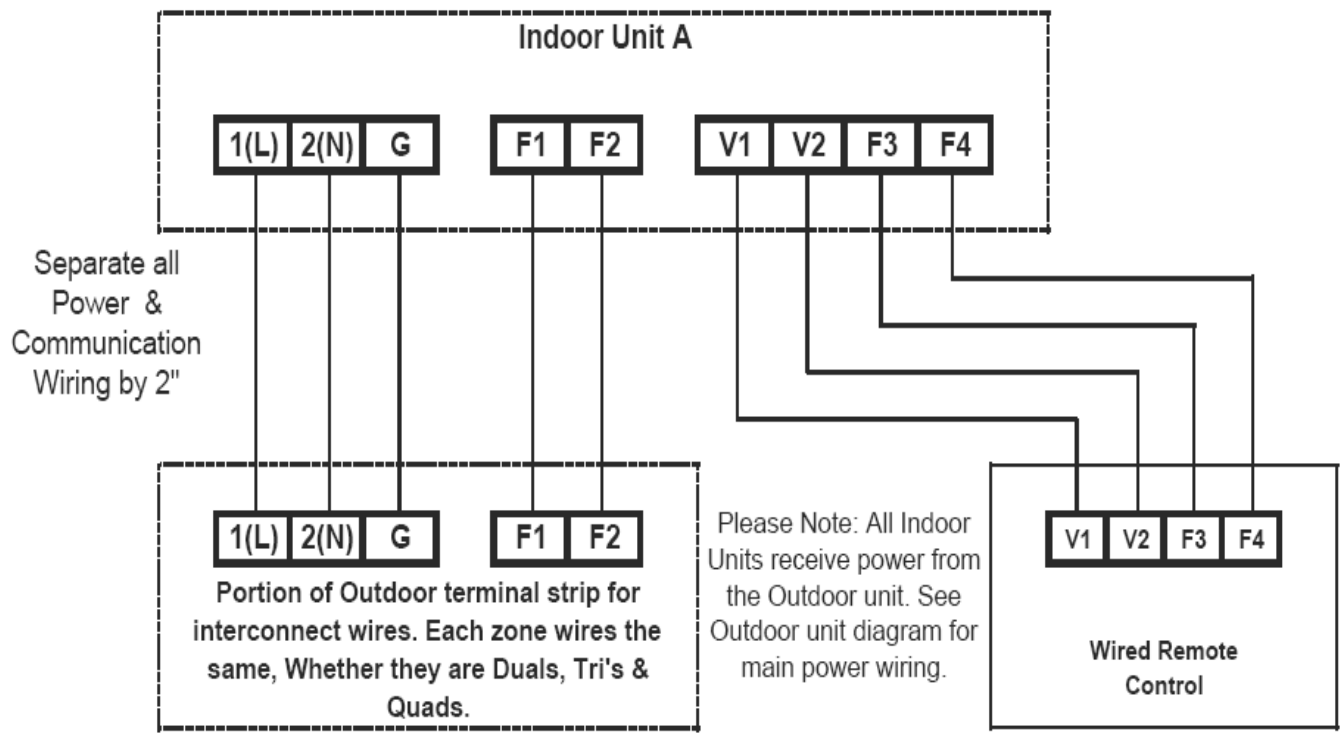



## **NJ052MHXCA Multi Multi Zone** **Mini 4 Way Cassette Heat Pump Indoor Units**

Matching Outdoor unit: MH080FXCA4A

### **Power**

Power Voltage :	208/230V – 1 Ph – 60 Hz
Control Voltage :	DDC Fuzzy Logic
Main Breaker Size :	No Dedicated Circuit Indoor Unit is Powered by the Outdoor Unit

### **Line Sizes :**

“Liquid” (expanded gas) line	1/4”
Suction	1/2”

**ALL LINES MUST BE INSULATED SEPARATELY**

### **Interconnect Length**

Maximum Combined Length	Depends on match
Maximum / Minimum Individual Length	75 / 10 feet
Vertical lift	Depends on match (Trap required at 26ft)

(Note evaporator can be above or below condenser)

### **Charging**

Unit is charged for	Nitrogen Holding Charge Only
Additional Charge of R410A	See Outdoor Unit

### **Interconnecting Wiring**

Gauge	14 AWG Power, <b>1(L), 2(N)</b> & 16 AWG Shielded Communication, <b>F1, F2</b>
Number of Interconnecting Wires	3x14 AWG Power & 2x16 AWG Control = 5 Total

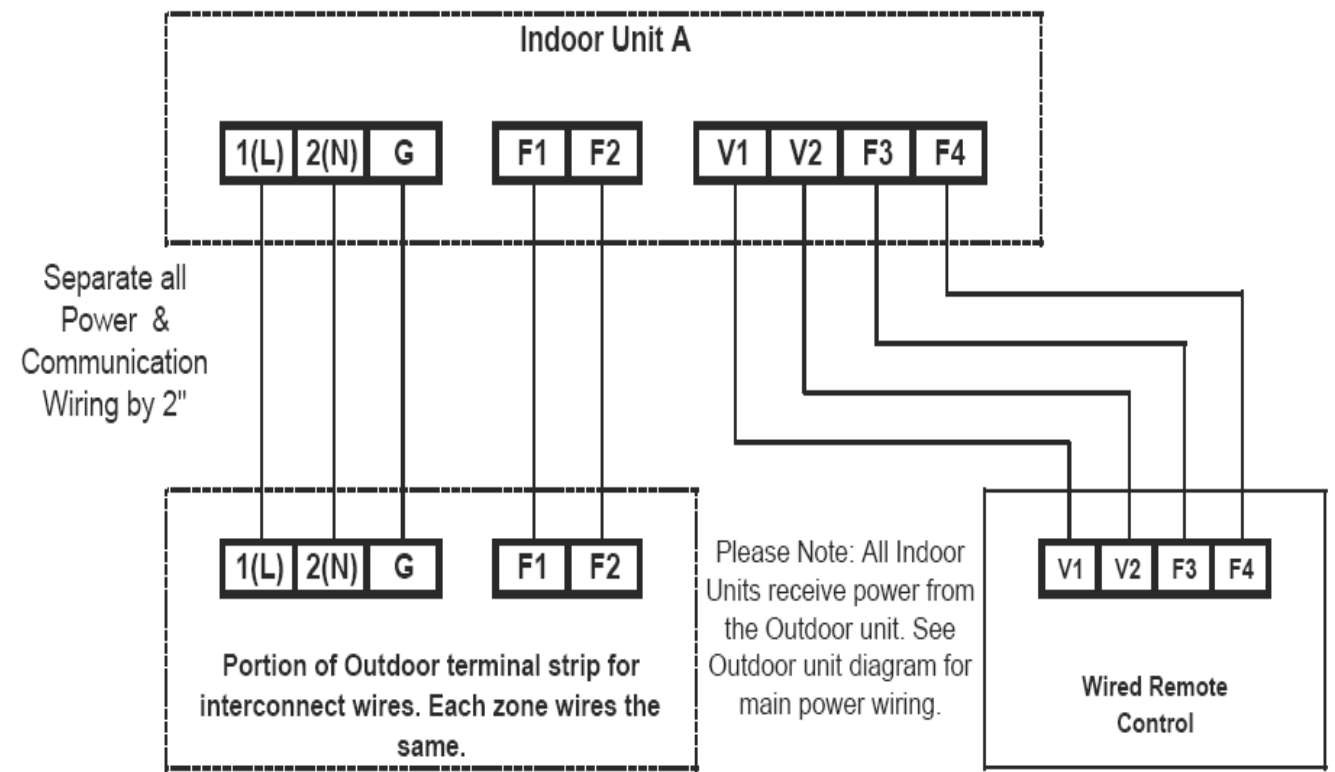



## **NJ0261HXCA & NJ0351HXCA Multi Zone Mini 1 Way Cassette Heat Pump Indoor Units**

Matching Outdoor units: MH050FXCA2A & MH080FXCA4A

### **Power**

Power Voltage :	208/230V – 1 Ph – 60 Hz
Control Voltage :	DDC Fuzzy Logic
Main Breaker Size :	No Dedicated Circuit Indoor Unit is Powered by the Outdoor Unit

### **Line Sizes :**

"Liquid" (expanded gas) line	1/4"
Suction	3/8"

**ALL LINES MUST BE INSULATED SEPARATELY**

### **Interconnect Length**

Maximum Combined Length	Depends on match
Maximum / Minimum Individual Length	75 / 10 feet
Vertical lift	Depends on match (Trap required at 26ft)

(Note evaporator can be above or below condenser)

### **Charging**

Unit is charged for	Nitrogen Holding Charge Only
Additional Charge of R410A	See Outdoor Unit

### **Interconnecting Wiring**

Gauge	14 AWG Power, <b>1(L), 2(N)</b> & 16 AWG Shielded Communication, <b>F1, F2</b>
Number of Interconnecting Wires	3x14 AWG Power & 2x16 AWG Control = 5 Total

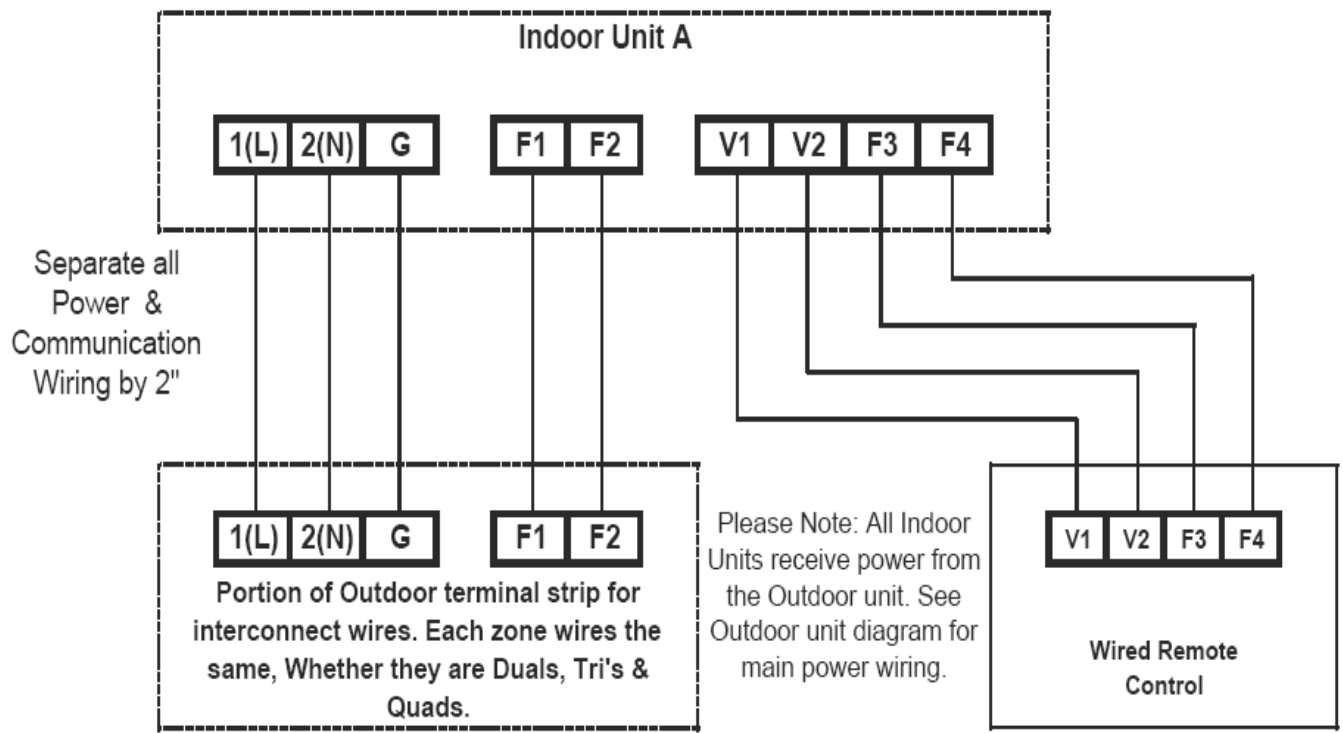



## \*FJM (MH) Model Series Systems Auto Addressing

### Step 1

- Rotary switch signifies number of Indoor units connected to Outdoor
- Set the rotary switch to the number of units, either 2, 3 or 4

### Step 2

- Auto Addressing
- Indoor units rotary switches do not need to be altered
- Leave all Dip switches on the Outdoor unit to the factory settings
- Turn on the unit, it will start a count to check communications with all Indoor units
- LH display will count 00 to 15
- Once Indoor units are tracked it will scroll 00 as it finds the Indoors
- Unit will now display E199 asking for a pipe check
- MWR-WH00 will display E599
- Press K1 switch once
- This starts the auto addressing mode
- Display will show |-5
- Compressor will start and the unit will open each EEV in turn to check that the correct indoor unit is connected to the correct EEV
- Unit will display on other LED the results scrolling 00, 01, 02, 03 as it establish communication

### Step 3

- Once completed it will display an OK signal, now the unit can be run in test mode, either Cooling or Heating
- Press K2 Button ONCE for Heating Trial mode : Display will show |-1
- Press K2 Button TWICE to add refrigerant : Display will now show |-2
- Press K2 Button THREE times for Cooling trial mode : Display will now show |-3
- Press K2 Button FOUR times for Pump Down mode : Display will now show |-4
- 

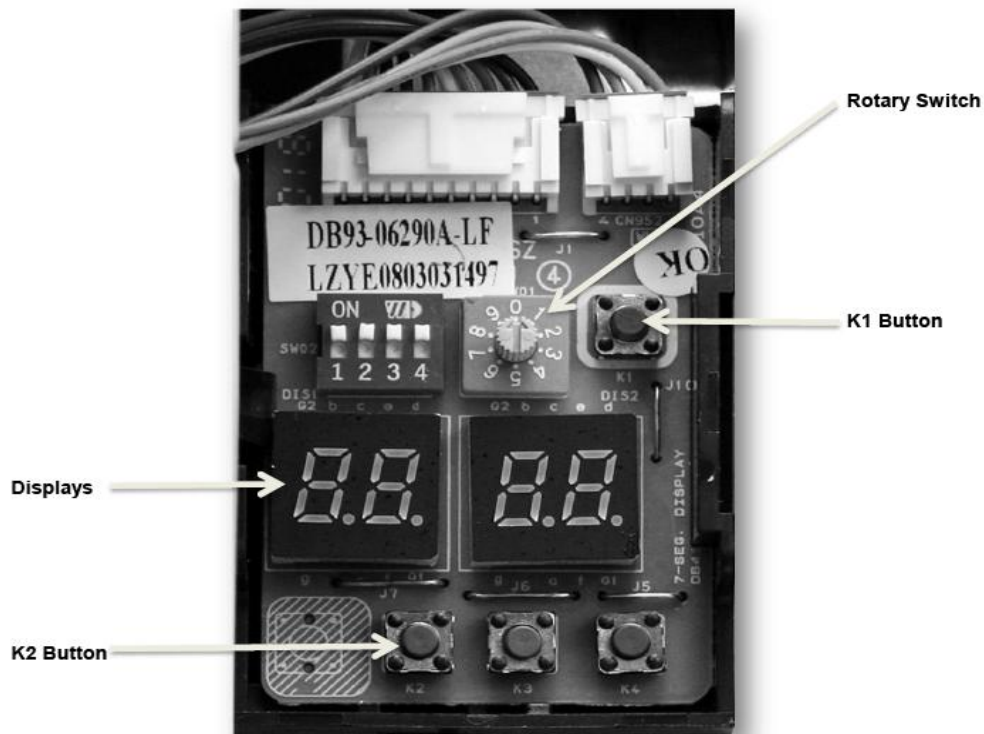

\* Please note: the Auto Addressing Procedure cannot be used on Slim Duct air handlers, Neo Forte High Wall indoor units that have been installed with the optional MWR-WH00 wired remote or that are piped in nonconsecutive order from the top set of valves down on the outdoor unit. These scenarios require the use of the Manual Addressing procedure.



## \*FJM (MH) Model Series Systems Manual Addressing

### Step 1

- Manual addressing is used when a BMS system is used or Ducted and Wall Mount units have Wired Remote controls
- Set the rotary switch to the number of units, either 2, 3 or 4

### Step 2

- Manual Addressing
- \*Set Dip Switch #1 on Outdoor unit to OFF

### Step 3

- On Indoor units set SW02 the MAIN address to the following based on which set of refrigerant connections the unit is piped to
- Unit piped to the top set of connections = 0
- Unit piped to the second set of connections from top = 1
- Unit piped to the third set of connections from top = 2
- Unit Piped to the lowest set of connections = 3
- System can now be powered up

### Step 4

- On initial power up LH display will scroll 00 Through 15
- Once Indoor units are tracked LH display will show 00, 01, 02 and 03 depending how many Indoor units are installed

### Step 5

- Use the K2 Button to put the unit into either Cooling or Heating trial mode
- Press K2 Button ONCE for Heating Trial mode : Display will show |-1
- Press K2 Button TWICE to add refrigerant : Display will now show |-2
- Press K2 Button THREE times for Cooling trial mode : Display will now show |-3
- Press K2 Button FOUR times for Pump Down mode : Display will now show |-4

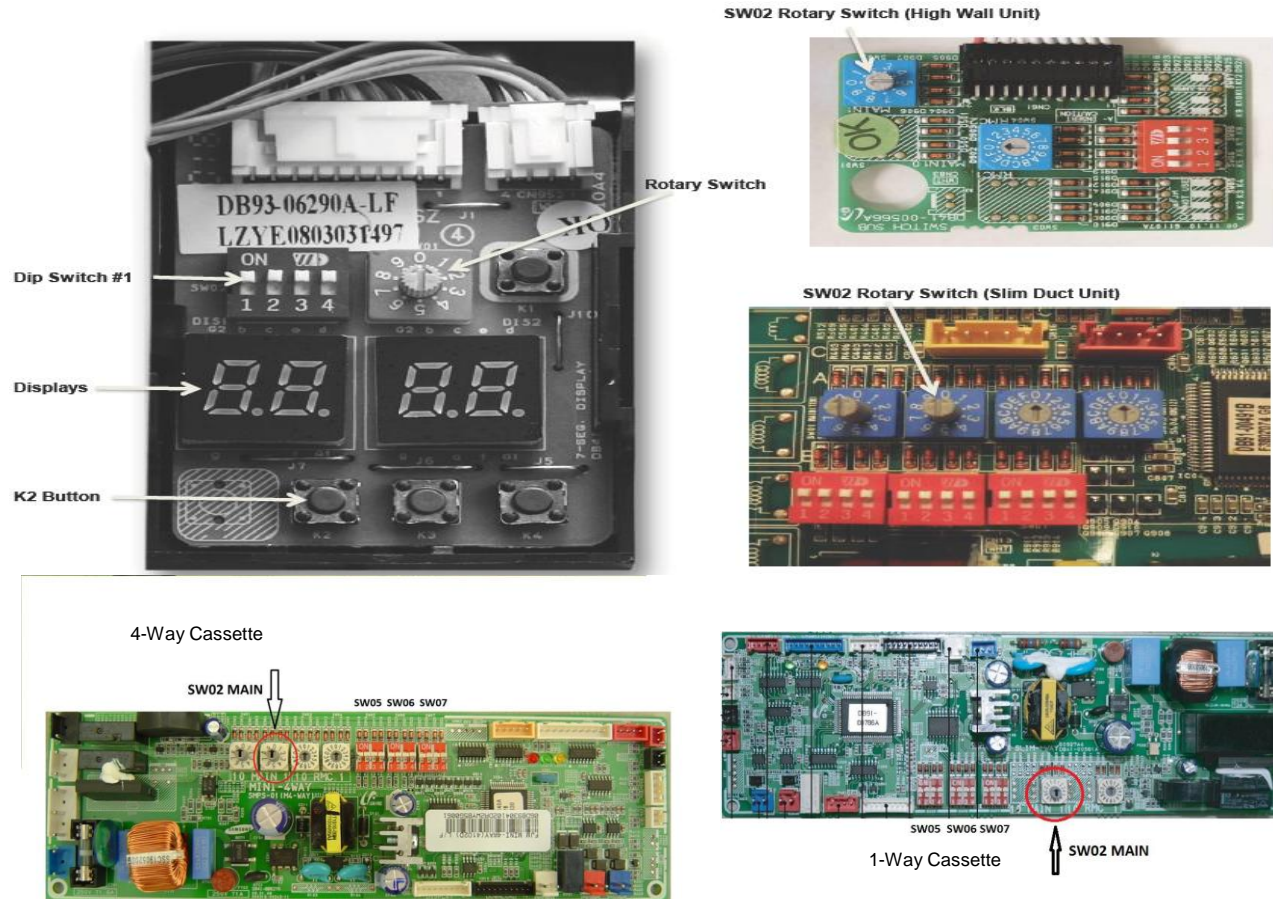

\* Dip Switch #1 should be in the OFF position (MANDATORY on the FECA Ducted unit)





## **Basic Installation Tips**

### **Sizing**

**Computer/Data Rooms :** Basic sizing is 200-250 sqft per 12,000 Btu/h

**Commercial/Retail :** Basic sizing is 400-450 sqft per 12,000 Btu/h

**Residential :** Basic sizing is 550-600 sqft per 12,000 Btu/h

### **Low Ambient Cooling**

**Computer/Data Rooms and Commercial:** As standard these units have low ambient cooling capability down to 10 DegF outdoor temperature.

**THESE UNITS CANNOT OPERATE IN COOLING BELOW 10 DEG F AMBIENT TEMPERATURE, UNLESS EQUIPPED WITH AN APPROVED WIND BAFFLE TO PROTECT THE OUTDOOR UNIT, IN WHICH CASE PERFORMANCE CAN BE EXPECTED DOWN TO 0 DEG F OUTDOOR TEMPERATURE. ALTHOUGH IF A PROLONGED OFF CYCLE IS EXPERIENCED, THE UNIT MAY NOT RESTART.**

### **R410A Refrigerant**

Higher pressures (close to double) than R22, but the operating temperatures are very similar to those with R22, for example

R410A      A saturated suction temp of 45 DegF = Suction Pressure of 130 Psig  
R22                      A saturated suction temp of 45 DegF = Suction Pressure of 76 Psig

R410A uses a POE oil compared to the mineral oil used with R22, the POE oil is attractive to water so it is very important to :

Minimize the time that the system is open to the atmosphere  
Ensure that a deep vacuum is pulled on the system, 200 microns or less  
Do not install any sight glasses or filter driers in the line set.

**Note: It is not necessary to remove refrigerant for line sets shorter than the specified length of the factory charge.**

## **R410A Refrigerant (continued)**

The gauge connection on the Samsung units is a 5/16" male, so an adaptor, part # R410A-ADPT (Yellow Jacket item #19173) is required to connect a standard North American set of R410A gauges to the Samsung unit.

### **Unit location**

**Indoor unit :** High Wall units should be located a minimum of 4ft from the ground. Also, some of the Indoor unit clearances listed in the specific unit Installation Manuals can be decrease to a minimum clearance of 2 inches from the ceiling to the top of the unit, while still maintaining unit performance and efficiency levels. **Ensure that no obstacles are directly in front of the unit for a Minimum Distance of 10-12ft on the AQV/N09 & 12, MH026/035FNCA, 20-25ft on the AQV/N18 & 24, MH052FNCA and 25-30ft on the AQV/N36** so that bounce back of the conditioned air is prevented and adequate airflow is maintained, keeping the indoor coil warm and allowing the system to run to full capacity when necessary. If any system is prevented from running at full capacity regularly, whether it is from impeded airflow or over sizing, it will have an adverse affect on the system ability to properly return oil to the compressor. Over time this will cause inconsistent performance, error codes, and premature failure of components.

Ceiling Cassette units must have a Minimum Distance of 5ft from the louver opening to any wall or other obstacle for the same reasons as listed above.

**Outdoor unit : Ensure line set runs are adhered to, it is required that a minimum line set length of 10ft maintained and exceeding the published maximum line set length is not permitted, under any circumstance.**

Also, keep in mind that, since the expansion valve is located in the outdoor unit, the line set is merely an extension of the indoor coil and, although insulated, the longer the line set run is the more likely there will noticeable loss of capacity.

Minimum clearances of 6" behind and 24" in front of the outdoor unit must also be maintained, enough clearance must be maintained from the sides to accommodate service of the unit.

Since these units are heat pumps, Raise up Outdoor unit 4 to 6" from the pad/ground to help drain the unit after a defrost cycle. Also, ensure unit is capable of operating in desired ambient temperatures. As previously stated, if the outdoor coil temperature is allowed to drop below 10 DegF, the system will lock out, not restarting until that temperature rises above 14 DegF.

Quietside West : Tel : 562 699 6066, Fax : 562 699 4351, Web : [www.quietside.com](http://www.quietside.com)  
Quietside Central : Tel : 817 838 6066, Fax : 817 838 8670, Web : [www.quietside.com](http://www.quietside.com)  
Quietside East : Tel : 717 243 2535, Fax : 717 243 7917, Web : [www.quietside.com](http://www.quietside.com)

## Notes

