

Job Name \_\_\_\_\_  
 Purchaser \_\_\_\_\_  
 Submitted to \_\_\_\_\_  
 Unit Designation \_\_\_\_\_

Location \_\_\_\_\_  
 Engineer \_\_\_\_\_  
 Reference Approval Construction  
 Schedule # \_\_\_\_\_

**Specifications**

Model	Indoor Unit Model Number		AC036JN4DCH/AA
	Outdoor Unit Model Number		AC036JXADCH/AA
Performance	Nominal Capacity	Cooling / Heating (Btu/h)	36,000 / 40,000
	Capacity Range	Cooling (Btu/h)	14,000 - 40,000
		Heating (Btu/h)	11,500 - 48,000
	SEER / EER		20.5 / 12.1
	COP (nominal heating)		3.37
	HSPF		9.5
	AHRI Certification Number		7918788
Condensate (pints/hour)		8.5	
Power	Voltage	ø / V / Hz	1 / 208-230 / 60
	Working Voltage Range (VAC)		176 - 254 (max. 3% deviation from each)
	Operating Current (min. / std. / max.)	Cooling (A)	4.8 / 13.8 / 17.0
		Heating (A)	3.7 / 16.1 / 23.0
	Max. Breaker	Amps	35
Min. Circuit Ampacity (A)		25.5	
Dimensions	W X H X D (inches)	Indoor Unit	33 X 11 5/16 X 33
		Outdoor Unit	37 X 48 X 13
	Weight (lbs.)	Indoor Unit	41.89
		Outdoor Unit	194
Heat Exchanger	Indoor & Outdoor Unit	Type	Aluminum Fin / Copper Tube
		FPI	18
	Outdoor Unit	Pipe Diameter (inches)	1/4
		Type	Aluminum, flat fin, micro channel
Sound Pressure Level	Indoor Unit dB(A)	L / M / H	33 / 38 / 43
	Outdoor Unit dB(A)	Cooling / Heating (high)	49 / 51
Operating Temperatures (°F)	Outdoor	Cooling	23 ≤ T ≤ 115
		Heating	0 ≤ T ≤ 115 w/wind baffle
		Heating	-4 ≤ T ≤ 76
	Indoor	Cooling	61 ≤ T ≤ 90
		Heating	T ≤ 80
Pipe Connections	Indoor & Outdoor	High side (flare)	3/8"
		Low side (flare)	5/8"
	Maximum (ft.)		246
	Maximum Vertical Separation (ft.)		98
Condensate Connection		1 1/8" OD	
Refrigerant	Type		R410A
	Control Method		Electronic Expansion Valve
	Factory Charge	oz.	98.77
	Charged for		25 feet
Additional Refrigerant		0.355 oz/ft over 25 feet	
Compressor	Manufacturer		Samsung
	Type		Inverter Driven, Twin BLDC, Rotary
	RLA	A	17.0
Evaporator Fan	Type		BLDC With Turbo Type Fan (1)
	Air Volume	CFM (L/M/H)	840 / 960 / 1180
	Output	Watts	97
	Operating Current	Amps	0.35
Condenser Fan	Motor		BLDC With Axial Type Fan (2)
	FLA / Watts / CFM (max.)		0.48 A X 2 / 125 W X 2 / 3,040 CFM
Fascia Panel	Model Number		PC4NUSKFN (purchased separately)
	L X W X H	Inches	37 3/8 X 37 3/8 X 1
	Weight	lbs.	13
Optional Accessories	Wired Controller	Simplified	MWR-SH00N
		Simplified Touch Controller	MWR-SH10N
		Premium w/scheduling	MWR-WE10N
	Wi-Fi Adapter		MIM-H03UN
	External Temperature Sensor		MRW-TA
	Wireless Controller		MR-EH00U
	External Contact Control		MIM-B14
	Central Control Interface Module for Connection to DVM Plus Controls (non-NASA)		MIM-N01
	Wall Bracket (for outdoor unit)		CKN-250
	Wind Baffles	Front	WBF-1 (requires 2)
Back		WBB-2	
Line Sets - insulated and flared, interconnect cables included	25' - ILS-2510		
	50' - ILS-5010		
Safety	Certifications		
	ETL & ETLc		
Devices	PCB fuses, indoor unit terminal block thermal fuse, current transformer, over-voltage protection, crankcase heating, temperature limit protection logic, compressor overload sensing		



- Low ambient control built in
- The outdoor unit shall supply power to indoor unit via 14 AWG X 3 power wire
- Auto-restart after power loss
- The outdoor unit shall have a snow accumulation prevention option setting to prevent snow drifting against an idle outdoor unit.
- The indoor and outdoor units shall have a removable EEPROM that stores system programming information, unit name, and other data
- All indoor unit addressing and option settings shall be done digitally; the indoor unit does not contain rotary dials or setting switches.
- Electro-static, washable, pleated filter as standard (included with fascia panel).
- Built in condensate pump and check valve with maximum 29" lift
- Knock-out for outside air capability (with booster fan connection)
- Fascia panel shall have LED indicator lights, IR receiver, and 4 motorized louvers (independent louver control is possible with wireless or premium wired controller).
- Pipe connections at the outdoor unit shall be made inside the unit chassis. Refrigerant pipes can exit through the front, side, rear, or bottom sides of the outdoor unit.
- The outdoor unit shall have a night time quiet mode option to reduce operating sound during the night (automatic or manual activation with dry contact signal).

- Construction**  
 The outdoor unit shall be galvanized steel with a baked on powder coated finish for durability
- The indoor unit shall be have a galvanized steel frame with HIPS chassis and fascia panel certified to UL94 V0.
- Heat Exchanger**  
 The indoor unit heat exchanger shall be mechanically bonded fin to copper tube
- The outdoor unit heat exchanger shall be aluminum, flat fin, micro channel
- Controls**  
 Control signal shall be a DDC type signal
- Interconnect control wire between outdoor indoor unit shall be 16 AWG X 2 shielded
- Wired or wireless controls must be purchased separately
- Connection to optional wired controllers shall be 16 AWG X 2 shielded wire
- Controls shall integrate with a BMS system
- The system shall integrate with the Samsung NASA Controls Solution

- No additional interface modules/adapters are required when connecting to Samsung NASA DVM S central control options (MIM-D00AN, MIM-B17N, MIM-B18N, MCM-A300N).
- Refrigerant System**  
 The refrigerant shall be R410A
- The compressor shall be hermetically sealed, inverter controlled, twin BLDC Rotary
- Refrigerant flow shall be controlled by an electronic expansion valve at outdoor unit
- Soft-start to reduce current demand during compressor start

**Warranty**  
 10 years compressor, 10 years parts, 1 year limited labor (conditions apply)

QuietSide maintains a policy of ongoing development, specifications are subject to change without notice. Refer to www.AHRI.directory.org for current reference numbers.

\* Nominal cooling capacities are based on: Indoor temperature: 80°F DB, 67°F WB. Outdoor temperature: 95°F DB, 75°F WB.  
 \* Nominal heating capacities are based on: Indoor temperature: 70 F DB, 60 F WB. Outdoor temperature: 47 F DB, 43 F WB.

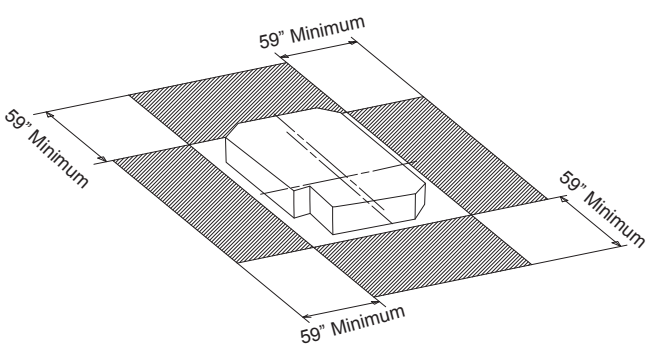
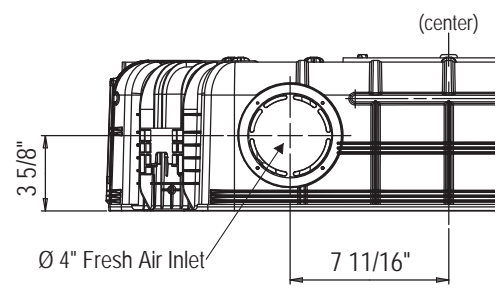
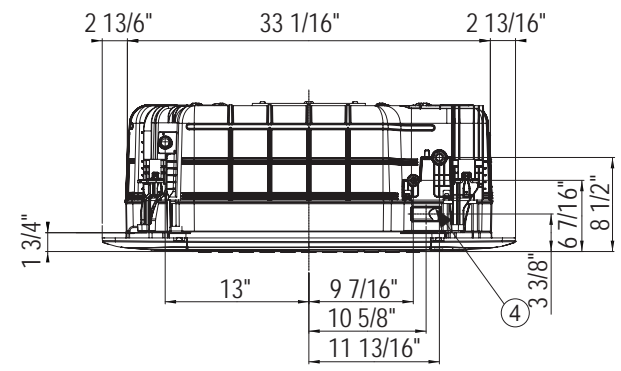
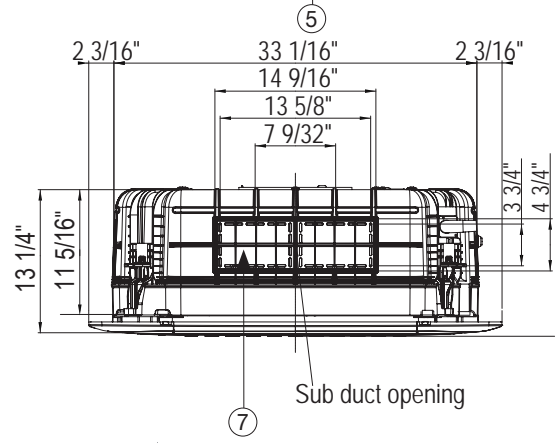
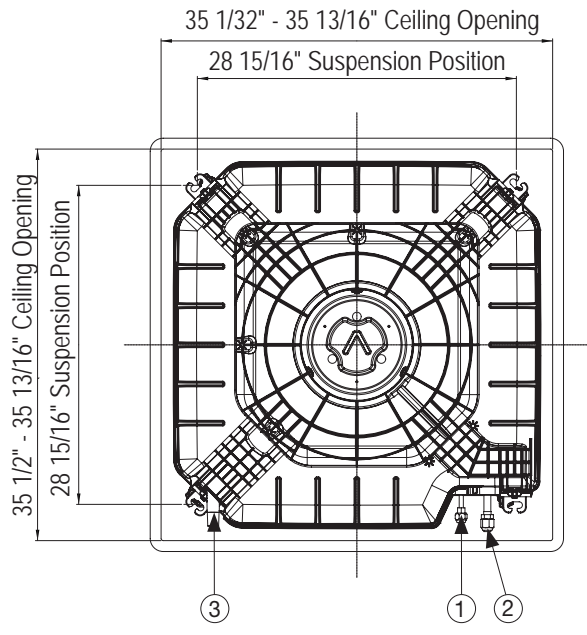
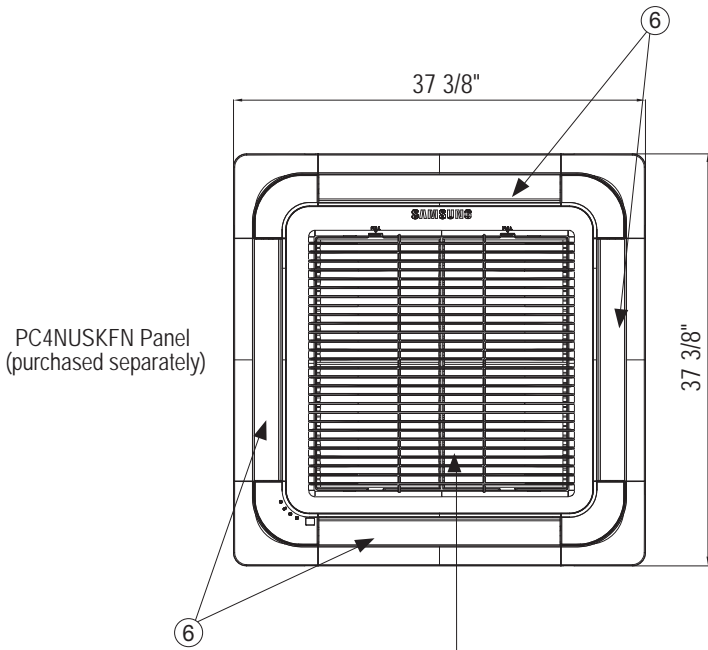

No.	Name	Description
①	Liquid Pipe Connection	Ø 3/8" Flare
②	Gas Pipe Connection	Ø 5/8" Flare
③	Drain Pipe Connection	OD 1 1/4", ID 1"
④	Conduit for Power & Communication Wiring	-
⑤	Air Inlet Grille	-
⑥	Air Outlet Louver	-
⑦	Sub Duct Outlet	-

Proper clearance must be maintained around unit for proper operation.

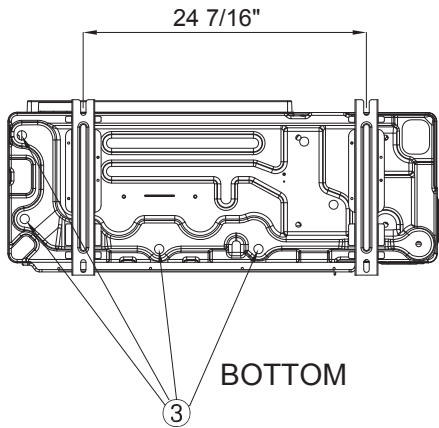
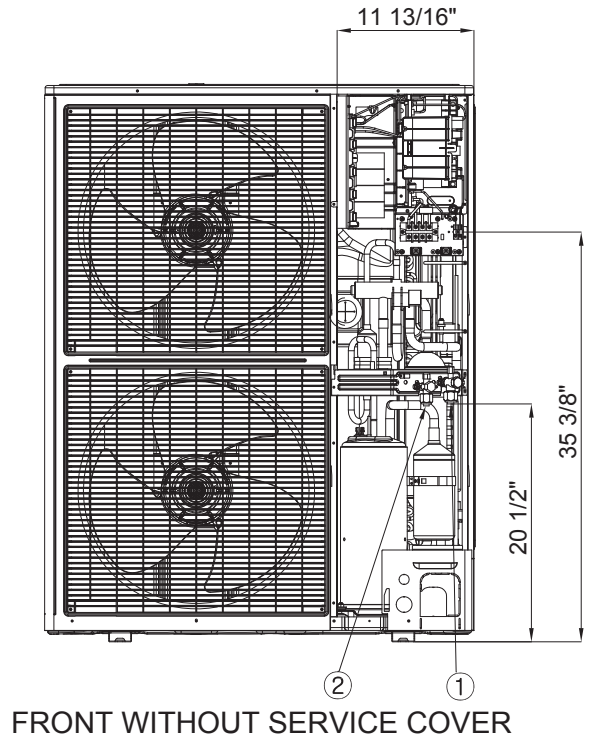
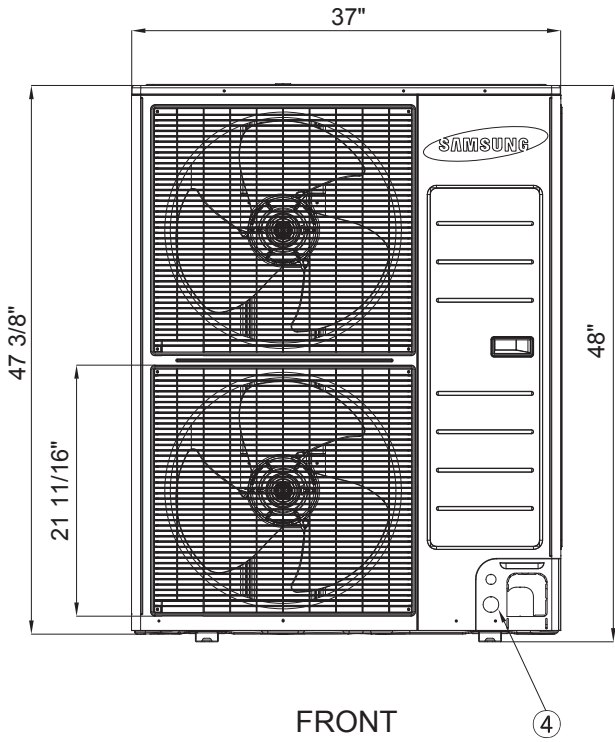
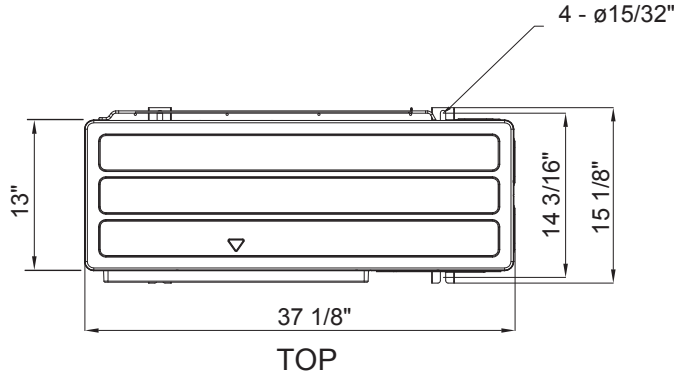

No.	Description
1	Suction service valve
2	Liquid service valve
3	Power and communication conduit openings