

Job Name _____
 Purchaser _____
 Submitted to _____
 Unit Designation _____

Location _____
 Engineer _____
 Reference _____ Approval _____ Construction _____
 Schedule # _____

Specifications

Model	Indoor Unit Model Number	AC018JNHDC/AA		
	Outdoor Unit Model Number	AC018JXADCH/AA		
Performance	Nominal Capacity	Cooling / Heating (Btu/h)	18,000 / 20,000	
	Capacity Range	Cooling (Btu/h)	5,000 - 21,000	
		Heating (Btu/h)	3,800 - 25,000	
	SEER / EER		19.6 / 11.2	
	COP (nominal heating)		3.4	
	HSPF		10.3	
	AHRI Certification Number		8032087	
Condensate (pints/hour)		4.26		
Power	Voltage	ø / V / Hz	1 / 208-230 / 60	
	Working Voltage Range (VAC)		176 - 254 (max. 3% deviation from each)	
	Operating Current (min. / std. / max.)	Cooling (A)		2.1 / 7.4 / 10.0
		Heating (A)		1.7 / 8.0 / 12.0
	Max. Breaker Amps		15	
Min. Circuit Ampacity (A)		8.6		
Dimensions	W X H X D (inches)	Indoor Unit	45 1/4 x 12 9/16 x 18 7/8	
		Outdoor Unit	34 5/8 X 25 1/8 X 12 1/4	
	Weight (lbs.)	Indoor Unit	94.8	
		Outdoor Unit	99	
	Duct Connections (W X H)	Supply (inches)	39 3/8 X 9 5/16	
Return (ID, inches)		37 1/2 X 8 3/4		
Heat Exchanger	Indoor & Outdoor Unit	Type	Aluminum Fin / Copper Tube	
		FPI	18	
		Pipe Diameter (inches)	1/4	
	Outdoor Unit	Type	Aluminum, flat fin, micro channel	
Sound Pressure Level	Indoor Unit dB(A)	L / M / H	26 / 30 / 34	
	Outdoor Unit dB(A)	Cooling / Heating (high)	48 / 48	
Operating Temperatures (°F)	Outdoor	Cooling	23 ≤ T ≤ 115	
		Heating	0 ≤ T ≤ 115 w/wind baffle	
	Indoor	Cooling	-4 ≤ T ≤ 76	
		Heating	61 ≤ T ≤ 90	
Pipe Connections	Indoor & Outdoor	High side (flare)	1/4"	
		Low side (flare)	1/2"	
	Maximum (ft.)		98	
	Maximum Vertical Separation (ft.)		66	
Condensate Connection		1" OD, 3/4" ID		
Refrigerant	Type		R410A	
	Control Method		Electronic Expansion Valve	
	Factory Charge oz.		45.86	
	Charged for Additional Refrigerant		25 feet	
			0.11 oz/ft over 25 feet	
Compressor	Manufacturer		Samsung	
	Type		Inverter Driven, Twin BLDC, Rotary	
	RLA Amps		6.1	
Evaporator Fan	Type		BLDC (1) With Sirocco Fan (2)	
	Air Volume	CFM (L/M/H)	390 / 490 / 590	
	Output (W) / FLA (A)		183 W / 0.85 A	
	Static Pressure	Standard ("WC)		0.12
Min. / Max. ("WC)			0 - 0.6	
Condenser Fan	Motor		BLDC With Axial Type Fan (1)	
	FLA / Watts / CFM (max.)		0.13 A / 39 W / 1,550 CFM	
Optional Accessories	Wired Controller	Simplified	MWR-SH00N	
		Simplified Touch Controller	MWR-SH10N	
		Premium w/scheduling	MWR-WE10N	
	Wi-Fi Adapter		MIM-H03UN	
	Wireless Signal Control	Wireless Signal Receiver	MRK-A01N	
		Wireless Controller	MR-EH00U	
	External Temperature Sensor		MRW-TA	
	Filter Box		FB-M3036	
	External Contact Control		MIM-B14	
	Central Control Interface Module for Connection to DVM Plus Controls (non-NASA)		MIM-N01	
	Wall Bracket (for outdoor unit)		CKN-250	
	Wind Baffles	Front		WBMF-9/12/18
		Back		WBMB-9/12/18/36
	Line Sets - insulated and flared, interconnect cables included			25' - ILS-2507
				50' - ILS-5007
Safety	Certifications	ETL		
	Devices: PCB fuses, indoor unit terminal block thermal fuse, current transformer, over-voltage protection, crankcase heating, temperature limit protection logic, compressor overload sensing			



- Horizontal discharge airflow
- Low ambient control built in
- The outdoor unit shall supply power to indoor unit via 14 AWG X 3 power wire
- Auto-restart after power loss
- The outdoor unit shall have a snow accumulation prevention option setting to prevent snow drifting against an idle outdoor unit.
- The indoor unit shall have a removable EEPROM that stores system programming information, unit name, and other data
- All indoor unit addressing and option settings shall be done digitally; the indoor unit does not contain rotary dials or setting switches.
- The indoor unit shall have a built-in condensate pump as standard with a 29" lift (from bottom of unit).
- The outdoor unit shall have a night time quiet mode option to reduce operating sound during the night.

Construction

The outdoor unit shall be galvanized steel with a baked on powder coated finish for durability

The indoor unit shall be insulated, galvanized steel.

Heat Exchanger

The indoor unit heat exchanger shall be mechanically bonded fin to copper tube

The outdoor unit heat exchanger shall be aluminum, flat fin, micro channel

Controls

Control signal shall be a DDC type signal

Interconnect control wire between outdoor indoor unit shall be 16AWG X 2 shielded

Wired or wireless controls must be purchased separately

Connection to optional wired controllers shall be 2 X 16AWG shielded wire

Controls shall integrate with a BMS system

The system shall integrate with the Samsung NASA Controls Solution

No additional interface modules/adapters are required when connecting to Samsung NASA DVM S central control options (MIM-D00AN, MIM-B17N, MIM-B18N, MCM-A300N).

Refrigerant System

The refrigerant shall be R410A

The compressor shall be hermetically sealed, inverter controlled, twin BLDC Rotary

Refrigerant flow shall be controlled by an electronic expansion valve at outdoor unit

Soft-start to reduce current demand during compressor start

Warranty

10 years compressor, 10 years parts, 1 year limited labor (conditions apply)

QuietSide maintains a policy of ongoing development, specifications are subject to change without notice. Refer to www.AHRIDirectory.org for current reference numbers.

* Nominal cooling capacities are based on: Indoor temperature: 80°F DB, 67°F WB. Outdoor temperature: 95°F DB, 75°F WB.
 * Nominal heating capacities are based on: Indoor temperature: 70 F DB, 60 F WB. Outdoor temperature: 47 F DB, 43 F WB.



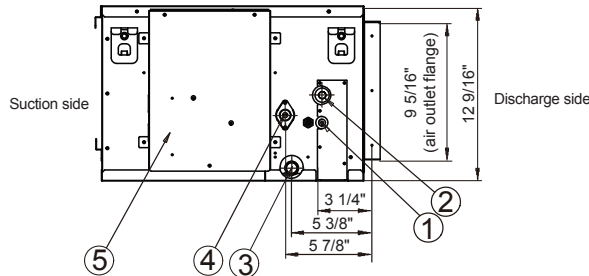
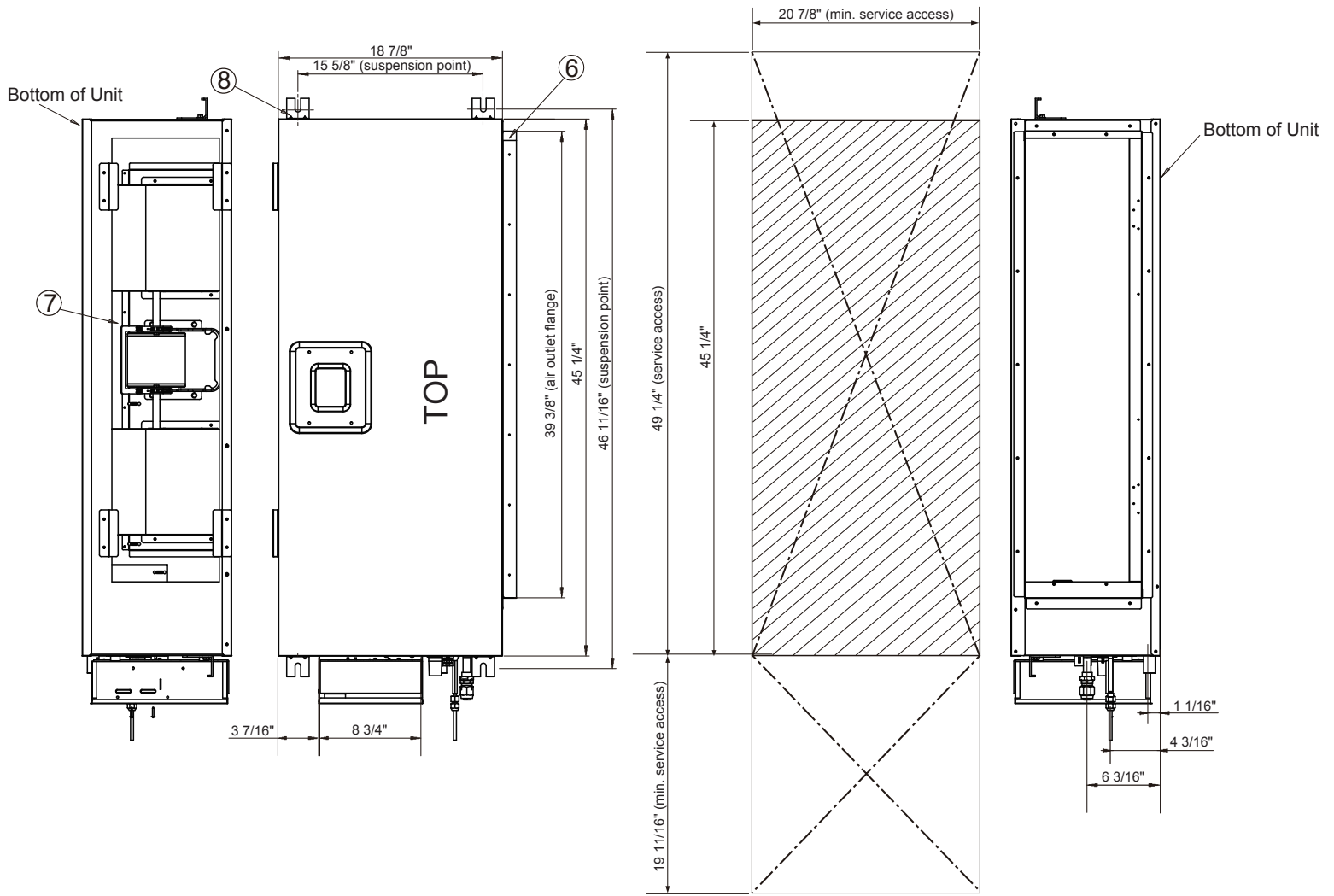

No.	Name	Description
①	Liquid Pipe Connection	Ø 1/4" Flare
②	Gas Pipe Connection	Ø 1/2" Flare
③	Drain Pipe Connection (gravity drain)	OD 1", ID 3/4"
④	Drain Pipe Connection (condensate pump)	OD 1", ID 3/4"
⑤	Control Box	-
⑥	Air Discharge Flange	-
⑦	Air Inlet	-
⑧	Suspension Hook	5/16" - 3/8"

Inspection Opening Requirements

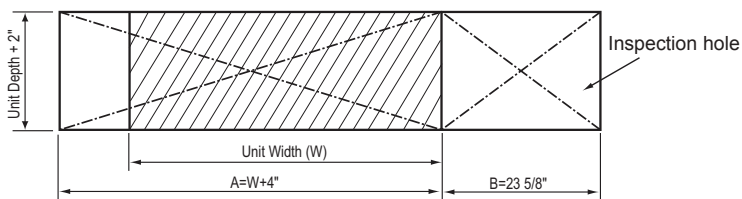

Unit Clearance From Structure

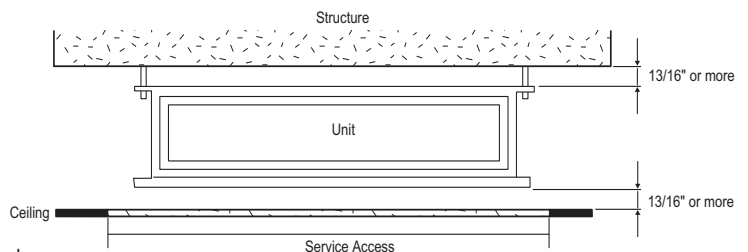

In applications where there is not a tile ceiling, an inspection hole is required.
 If height between ceiling and structure is 3.25' or more, inspection opening "B" is recommended.
 If height between ceiling and structure is less than 3.25', inspection opening "A" and "B" is recommended.
 (verify state and local codes).

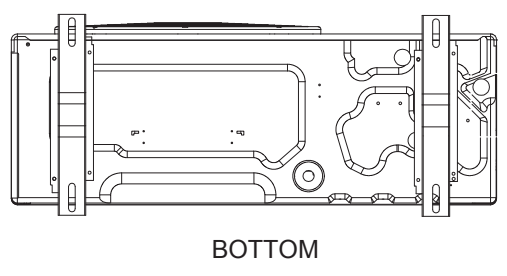
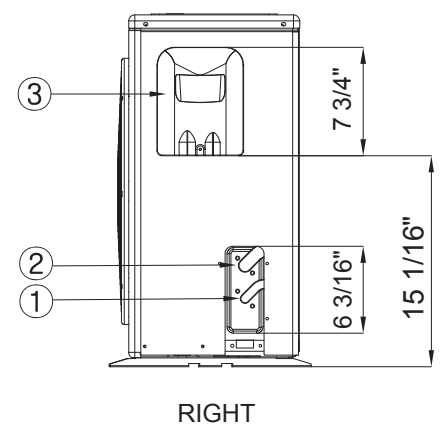
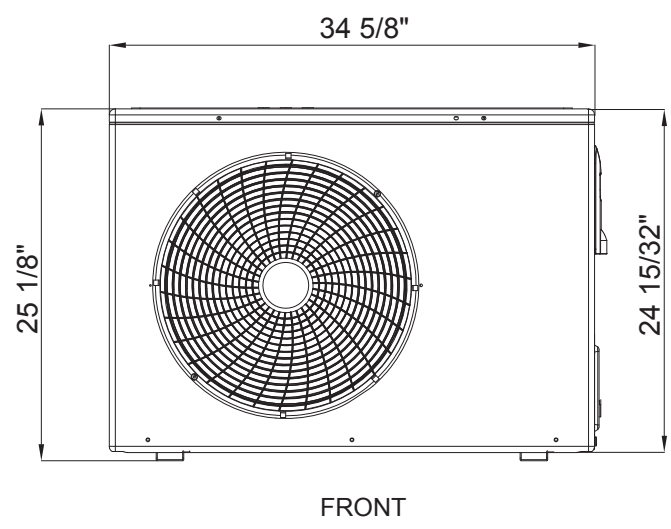
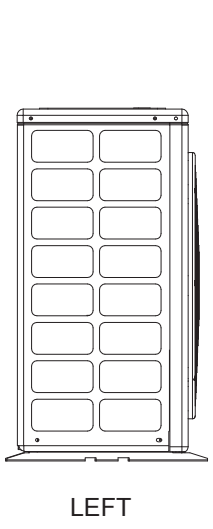
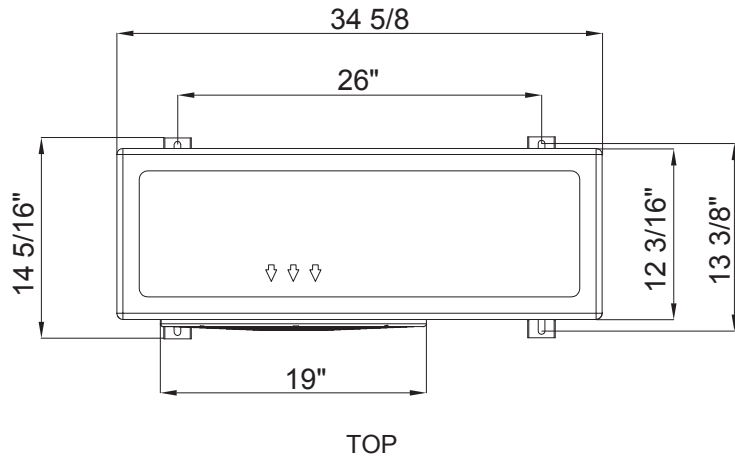

No.	Description
1	Liquid service valve
2	Suction service valve
3	Power and communication conduit openings