

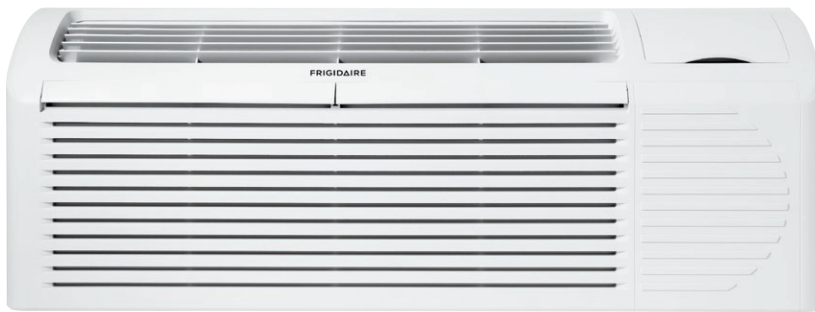

Packaged Terminal Air Conditioner (PTAC) FRP77ETT3A

**Air Conditioner/
Electric Heater**



Signature Features

SilentDesign™

Sound reduction package.

Effortless™ Maintenance

With Frigidaire's reputation for durability, easy maintenance, availability of reliable parts and service you can count on, you can be sure that you're getting the highest-quality performance.

Energy-Saver Option

This function effortlessly maximizes energy efficiency while keeping guests comfortable.

Effortless™ Protection

An optional corrosion-resistant fin coating extends operation life and your investment, plus it is easier to maintain in coastal environments.

Product Dimensions

Height	16"
Width	42"
Depth	13-13/16"

More Easy-To-Use Features

Effortless™ Temperature Control

Frigidaire® air conditioners maintain the preset room temperature so the room remains comfortable at all times and helps control energy levels.

Comfort Control Design

Simple controls allow guests to customize their settings, while quiet, uniform air movement keeps rooms comfortable.

Smart Self-Check

Provides nine diagnostic points for self-check and correction of fault conditions.

Eco-Friendly

Frigidaire® uses R-410A refrigerant that's not harmful to the earth's ozone layer and meets U.S. Environmental Protection Agency requirements.

Effortless™ Operation

Simple, intuitive room controls are easy for guests to operate — ensuring a relaxing, more comfortable stay. Features like Effortless™ Restart and Ready-Select® controls reduce maintenance calls.

Performance	BTUs
Cool	7,200
Electric Heater	10,200



Performance	
BTU (Cool)	7,200
BTU (Electric Heater)	10,200
Dehumidification (Pints/Hour)	1.7
Cool Area (Sq. Ft.)	300
Energy Efficiency Ratio	11.0
Electrical	
Volts	265
Amps (Cool)	2.6
Amps (Electric Heater)	11.32
Watts (Cool)	655
Watts (Electric Heater)	3,000
Cable Included	Yes
Length of Power Cord	2.6'
Circuit Breaker	20A
Plug Type (NEMA)	LCDI (7-20P)
Features	
Electronic Controls	Ready-Select® Controls
Front Desk Control Ready	Yes
Fan Speeds (Cool/Fan/Heat)	3/3/3
Noise Level Indoors (High/Med/Low)	51/50/49
Quiet Start-Up	Yes
Low Voltage Start-Up	Yes
Random Restart Protection	Yes
Effortless™ Auto Freeze Protection	Yes
Energy Save	Yes
24-Hour On/Off Timer	Yes
Air CFM (High/Med/Low)	295/275/260
Air Direction Control	Auxiliary 2-Way
Air Intake	Fresh or Recycled
Filter Type	Nylon Mesh
Filter Access	Slide-Out
Fin Coating	Seacoast
Slide-Out Chassis	Yes
Commercial Grade Warranty ¹	Yes
Certifications	
Safety Certification	UL, CUL & CSA
Performance	AHRI & CEC
Specifications	
Refrigerant	R410a
Charge	19.75 oz.
Shipping Weight (Approx.)	123 Lbs.

¹Warranty 5 year sealed system/1 year full parts and labor.



Plug Type (NEMA)
7-20P

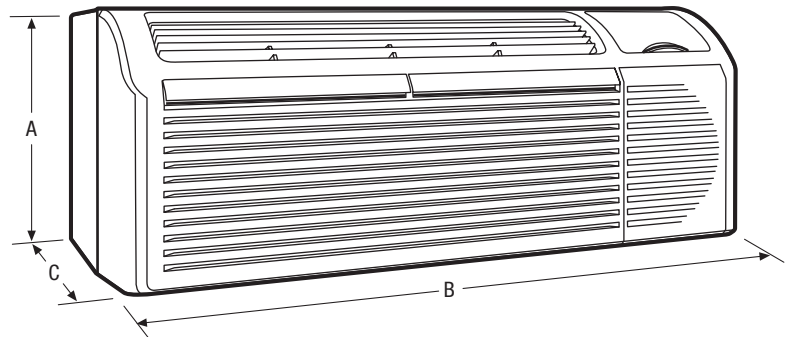
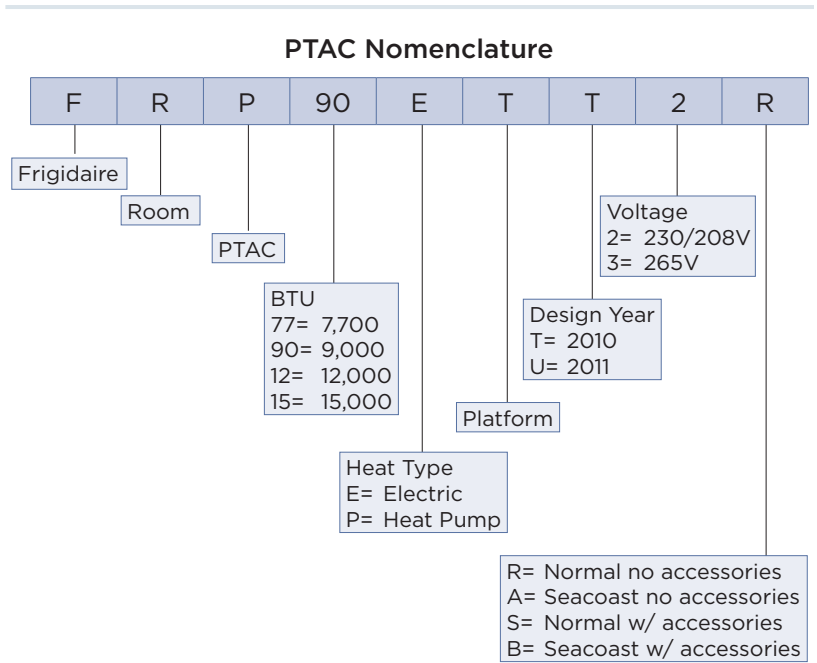

NOTE: For planning purposes only. Always consult local and national electric codes. Refer to Product Installation Guide for detailed installation instructions on the web at frigidaire.com.



Product Dimensions	
A - Height	16"
B - Width	42"
C - Depth	13-13/16"
Max. Wall Thickness	13-13/16" ²

Wall Cutout Dimensions	
Height	16-5/16"
Width	42-3/16"

²Unless the PTAC unit is installed with a wall sleeve.

Accessories information available on the web at frigidaire.com

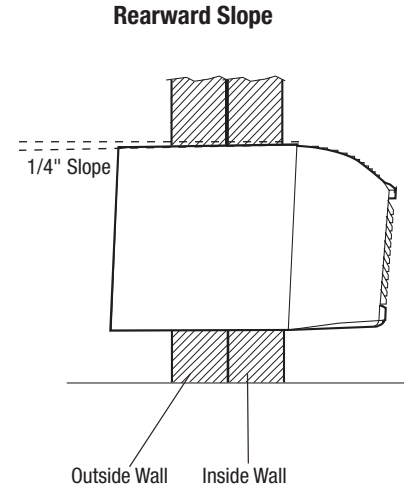
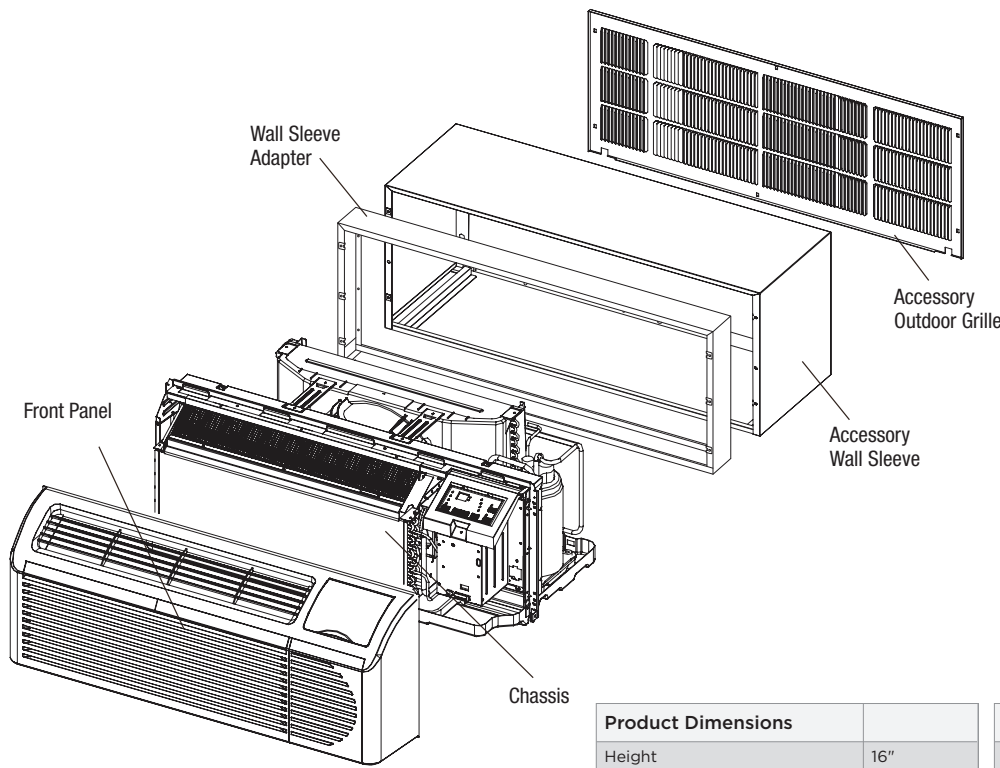

Product Dimensions	
Height	16"
Width	42"
Depth	13-13/16"
Max. Wall Thickness	13-13/16"

Wall Cutout Dimensions	
Height	16-5/16"
Width	42-3/16"

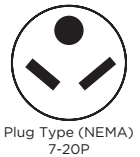

Plug Type (NEMA) 7-20P

PTAC Specifications

- Product Shipping Weight (approx.) - 123 Lbs.
- An electrical supply with grounded three-prong receptacle is required. The power supply circuit must be installed in accordance with current edition of National Electrical Code (ANSI/NFPA 70) and local codes & ordinances.
- Voltage Rating - 265V/60 Hz/20 Amps
- Amps @ 265V Volts = (Cool) 2.6 Amps/(Electric Heater) 11.32 Amps
- Always consult local and national electric codes.
- Recommended Circuit Breaker - 20 Amps
- Unit equipped with 265V 3-wire power supply cord, NEMA plug type 7-20P, approximately 2.6' long.
- In order for condensate water to drain properly inside the unit, the sleeve must be installed properly: Level from right to left with a slight 1/4" rearward pitch from the indoor side to the outdoor side as shown in the illustration above. Refer to the Installation Instructions on the web.
- The drain kit listed on the Frigidaire® PTAC Accessories page can be used for an internal or external drain. This applies to new and replacement installation.

New Installation

- For new installation, Frigidaire® PTAC Sleeves are available and recommended for proper installation. See accessories pages for sleeve options.*
- Standard PTAC installation requires 13-13/16" maximum wall thickness, unless a wall sleeve is used.
- If the PTAC unit protrudes more than 4", then it is suggested that it be installed with a subbase. See accessories pages for subbase options.

Replacement Installation

- When replacing existing PTAC with new unit, refer to Product Installation Guide on web to identify existing wall-sleeve manufacturer and size compatibility. If proper installation and slope are suspect, then correct installation of Frigidaire® PTAC Sleeve options recommended.
- For any sleeve retrofit application, be sure that the foam seals (factory-installed on the tube sheets) provide a good seal between the grille and the outdoor coil tube sheets. These foam seals provide a barrier that stops air from the inside mixing with air on the outside (known as air recirculation).
- Using Frigidaire® wall sleeve with Non-Frigidaire grille requires installation of an Accessory Baffle Kit, which ensures a good seal between the unit and exterior grille to prevent air recirculation. Air recirculation is a large contributor to performance loss and premature damage to major components.

Note: For planning purposes only. Refer to Product Installation Guide on the web at frigidaire.com for detailed instructions.

*See Frigidaire® PTAC accessories pages attached for optional accessories.

FRIGIDAIRE

USA • 10200 David Taylor Drive • Charlotte, NC 28262 • 1-866-942-1567 • frigidaire.com
 CANADA • 5855 Terry Fox Way • Mississauga, ON L5V 3E4 • 1-866-942-1567 • frigidaire.ca
 FRP77ETT3A 10/11

