

# Quest 185 Cool

## Installation, Operation and Maintenance Instructions

– Read and Save These Instructions –

*This manual is provided to acquaint you with the dehumidifier so that installation, operation and maintenance can proceed successfully. Ultimate satisfaction depends on the quality of installation and a thorough understanding of this equipment. The dehumidifier is built around tested engineering principles and has passed a thorough inspection for quality of workmanship and function.*



### Features:

- 4,300 BTU Cooling
- Industry-leading efficiency
- Patented, optimized air-to-air heat exchanger
- High-efficiency, long-life impeller fan
- Quiet operation
- Superior air filtration (MERV-11 standard)
- Auto-restart after power outages
- Environmentally friendly R410A refrigerant
- Low voltage control

### Water Removal Rates (Pints/Day) @ 80°F 60% (AHAM)

Dehumidifier	Pints Removed	Gallons/Liters
185 Cool	184	23.0/87.2

INSTALLATION BY A HVAC PROFESSIONAL IS RECOMMENDED

**HVAC Installer: Please Leave Manual for Homeowner**

P/N: 4033180    Serial No.: \_\_\_\_\_    Install Date: \_\_\_\_\_

Sold by: \_\_\_\_\_



4201 Lien Rd  
Madison, WI 53704  
www.QuestHydro.com

Phone 608-237-8400  
Toll-Free 1-877-420-1330  
info@QuestHydro.com

- Safety Instructions ..... 3
- 1. Intended Application for Quest 185 Cool Dehumidifier ..... 4
- 2. Registrations..... 4
- 3. Parts List Included ..... 4
- 4. Specifications ..... 4
- 5. Installation ..... 5
  - 5.1 Dehumidifier Setup..... 5
    - 5.1 A Location ..... 5
    - 5.1 B Electrical Requirements..... 6
    - 5.1 C Condensate Water Removal ..... 6
    - 5.1 D Hanging Diagram ..... 7
    - 5.1 E Ducting ..... 7
  - 5.2 Condenser Setup..... 7
    - 5.2 A Location ..... 7
    - 5.2 B Electrical Requirements..... 8
  - 5.3 Line Set Installation..... 9
  - 5.4 Brazing the Line Set..... 11
  - 5.5 Leak Test Line Set and Dehumidifier..... 13
  - 5.6 Evacuating the Line Set and the Dehumidifier ..... 14
  - 5.7 Charging the System..... 15
- 6. Control Options..... 16
  - 6.1 On Board Dehumidistat ..... 16
  - 6.2 External Control..... 17
    - 6.2 A DEH 3000R ..... 18
    - 6.2 B Honeywell Remote Humidstat..... 18
- 7. Maintenance ..... 18
  - 7.1 Standard Air Filter ..... 19
  - 7.2 Impeller Fan Oiling ..... 19
- 8. Service ..... 19
  - 8.1 Warranty ..... 19
  - 8.2 Refrigerant Charging ..... 19
  - 8.3 Service Parts List - Dehumidifier ..... 19
  - 8.4 Service Parts List - Condensing Unit..... 20
  - 8.5 Troubleshooting ..... 20
- 9. Wiring Diagrams ..... 22
  - 9.1 Dehumidifier Wiring Diagram..... 23
  - 9.2 Condenser Wiring Diagram..... 23
  - 9.3 Dehumidifier and Condenser Wiring Diagram..... 23
- 10. Optional Accessories ..... 24
- Warranty ..... 25



## Safety Precautions

Read the installation, operation and maintenance instructions carefully before installing and operating this device. Proper adherence to these instructions is essential to obtain maximum benefit from your **Quest 185 Cool** Dehumidifier.

### READ AND SAVE THESE INSTRUCTIONS

- The Dehumidifier portion is designed to be installed **INDOORS IN A SPACE THAT IS PROTECTED FROM RAIN AND FLOODING.**
- The Condensing unit needs to be protected from the elements (direct sunlight, rain, snow, etc.) but can be outdoors.
- Install the unit with space to access the back or side panels for maintenance and service. **DO NOT INSTALL UNIT WITH THE SERVICE PANELS INACCESSIBLE.**
- Avoid directing the discharge air at people, or over the water in pool areas.
- If used near a pool, spa or water; be certain there is **NO** chance the unit could fall into the water, be splashed and that it is plugged into an outlet that is a **GROUND FAULT INTERRUPT** protected circuit.
- **DO NOT** use the device as a bench or table.
- **DO NOT** place the device directly on structural members. Provide vibration isolation in order to minimize operational vibration and/or noise.
- A drain pan **MUST** be placed under the unit if installed above a living area or above an area where water leakage could cause damage
- Never operate a unit with a damaged power cord. If the power cord is damaged it must be replaced by the manufacturer, its service agent, or similarly qualified person in order to avoid a hazard.
- Make all electrical connections in accordance with the current edition of the **NEC ANSI/NFPA 70** and any national and local codes or ordinances that may apply.
- Do not obstruct the air intake and exhaust. Maintain a .3 m (1 ft) clearance around the air intake and exhaust.
- This appliance is not intended for use by persons (including children) with reduced physical, sensory or mental capabilities, or lack of experience and knowledge, unless they have been given supervision or instruction concerning use of the appliance by a person responsible for their safety. Children should be supervised to ensure that they do not play with the appliance.

### 1. Intended Application for Quest 185 Cool Dehumidifier

In order to efficiently control humidity levels, the area in which the dehumidifier is to be operated must be free of water intrusion or excessive fresh (outside) air infiltration. Before installing the Quest 185 Cool Dehumidifier, water intrusion and air infiltration problems should be addressed or noted in calculations.

### 2. Registrations

The Quest 185 Cool conforms to unified standard UL 474 and CSA Standard C22.2 No. 92.

### 3. Parts List Included

- Quest 185 Cool Dehumidifier
- Quest 185 Cool Condensing Unit
- Quest 185 Cool Installation Instructions
- Quest 185 Cool Leveling Feet

### 4. Specifications @ 80°F/60% RH

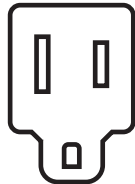
<b>Dehumidifier:</b>	<b>4037391</b>
<b>Power (Watts):</b>	160
<b>Supply voltage:</b>	110-120 VAC - 1 Phase - 60 Hz.
<b>Current Draw (Amps):</b>	1.4
<b>Energy Factor (L/kWh):</b>	3.1
<b>Operating Temp:</b>	56°F Min - 95°F Max
<b>Water Removal (Pints/Day):</b>	184
<b>Efficiency (Pints/kWh):</b>	6.6
<b>Air Filter (MERV-11):</b>	Size: 16" x 20" x 2"
<b>Power Cord</b>	14ga 10', NEMA 5-15P 
<b>Drain Connection:</b>	3/4" Threaded NPT
<b>Refrigerant Type:</b>	R410A
<b>Dimensions:</b>	
<b>Width:</b>	20.25"
<b>Height:</b>	21.75"
<b>Length:</b>	38"
<b>Weight:</b>	109 lbs

<b>Condenser:</b>	<b>4037392</b>
<b>Power (Watts):</b>	1080
<b>Supply voltage:</b>	110-120 VAC - 1 Phase - 60 Hz.
<b>Current Draw (Amps):</b>	9.7
<b>Minimum Circuit Ampacity:</b>	20
<b>Maximum Fuse/Breaker</b>	20
<b>Operating Temp:</b>	40°F Min - 115°F Max
<b>Power Cord</b>	Hard-Wired
<b>Refrigerant Type:</b>	R410A
<b>Refrigerant Amount:</b>	2lb. 4oz.
<b>Dimensions:</b>	
<b>Width:</b>	10"
<b>Height:</b>	25.5"
<b>Length:</b>	33"
<b>Weight:</b>	75 lbs

## 5. Installation

### 5.1 Dehumidifier Setup

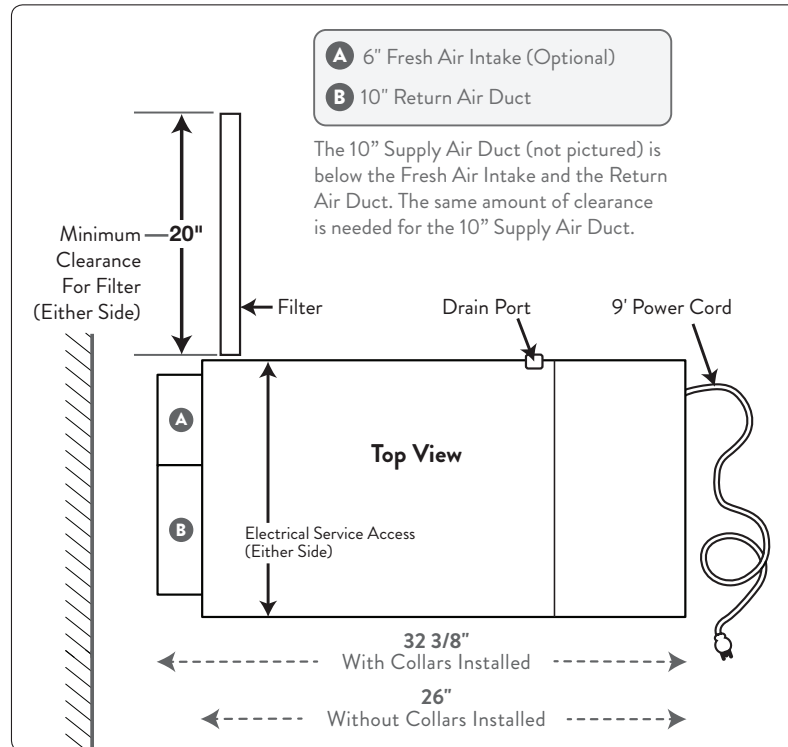

#### 5.1 A Location

The Quest 185 Cool Dehumidifier can be installed in a variety of locations to meet the owner's needs as listed below. In all cases keep the following cautions in mind:

- It is designed to be installed **INDOORS IN A SPACE THAT IS PROTECTED FROM RAIN AND FLOODING.**
- Install the unit with space to access the back and side panels for maintenance and service and also to allow easy access to the filter cover panel. **DO NOT INSTALL UNIT WITH THE FRONT PANEL OR FILTER COVER PANEL INACCESSIBLE.**
- Avoid discharging the air directly at people, or over the water in pool areas.
- Be certain there is **NO** chance the unit could fall into water or be splashed and that it is plugged into a **GROUND FAULT INTERRUPTER.**
- **DO NOT** use the Quest 185 Cool Dehumidifier as a bench or table.
- **DO NOT** place the Quest 185 Cool Dehumidifier directly on structural members. Provide vibration isolation in order to minimize operational vibration and/or noise.
- A drain pan **MUST** be placed under the unit if installed above an area where water leakage could cause damage.

Place the Quest 185 Cool Dehumidifier on supports that raise the base of the unit 2.5" above the top of the flanges on the drain pan beneath it. Raising the Quest 185 Cool Dehumidifier will help the unit drain with gravity flow. Do not place the Quest 185 Cool Dehumidifier directly on structural building members without vibration absorbers or unwanted noise may result.

The Quest 185 Cool Dehumidifier may be suspended with steel hanger straps or a suitable alternative from structural members, unit must be supported from underneath. Don't hang from sides or ends. Remember to place a drain pan under the unit if it is suspended above a finished area or above an area where water leakage could cause damage.

### 5.1 B Electrical Requirements

The Quest 185 Cool Dehumidifier plugs into NEMA rated Receptacles. The amp draws for each unit under normal operating conditions are listed on page 4. A ground fault interrupter protected circuit is required.

Install the remote control panel in a central area of the structure where it will sense the relative humidity of the structure accurately. Do not install the control panel where it may not accurately sense the relative humidity such as near HVAC supply registers, near exterior doors, or near a pool or spa. The installer must supply the wiring between the Quest 185 Cool Dehumidifier and the control panel. Be sure to safely route the control wiring to prevent damage during installation. Be careful not to cross the wires when connecting the Quest 185 Cool Dehumidifier and the remote control panel.

The remote controls of the Quest 185 Cool Dehumidifier are powered by a low voltage circuit (24 VAC) and must NEVER contact or be connected to a high voltage circuit. The control terminals and remote control are labeled and numbered to prevent confusion. Be sure to consult the electrical schematic in this manual or inside the access panel of the Quest 185 Cool Dehumidifier before making the control connections.

**⚠ CAUTION! For proper drainage, the unit must be mounted so the drain outlet is at least 4" above the floor drain, and must be fully supported under the base.**

### 5.1 C Condensate Water Removal

Condensate drains by gravity via the drain port. Use 3/4" male NPT PVC pipe. Route drain pipe to drain. Install a trap if possible. Take care when installing drain pipe to drain port. Use an adjustable wrench to secure the drain port. An optional condensate pump kit may be installed if a lift is required to dispose of the condensate. The condensate pump kit can be ordered directly from the factory. See the optional parts list for information on the kit.

When installing the drain hose make sure the feet are extended such that the dehumidifier is 2 1/2" off the ground. Then coil the drain hose under itself or position a spacer to lift the hose 1" off the ground after the hose has touched the ground. This procedure will create a trap that ensures your unit drains correctly. See the diagram below for further visual clarification.

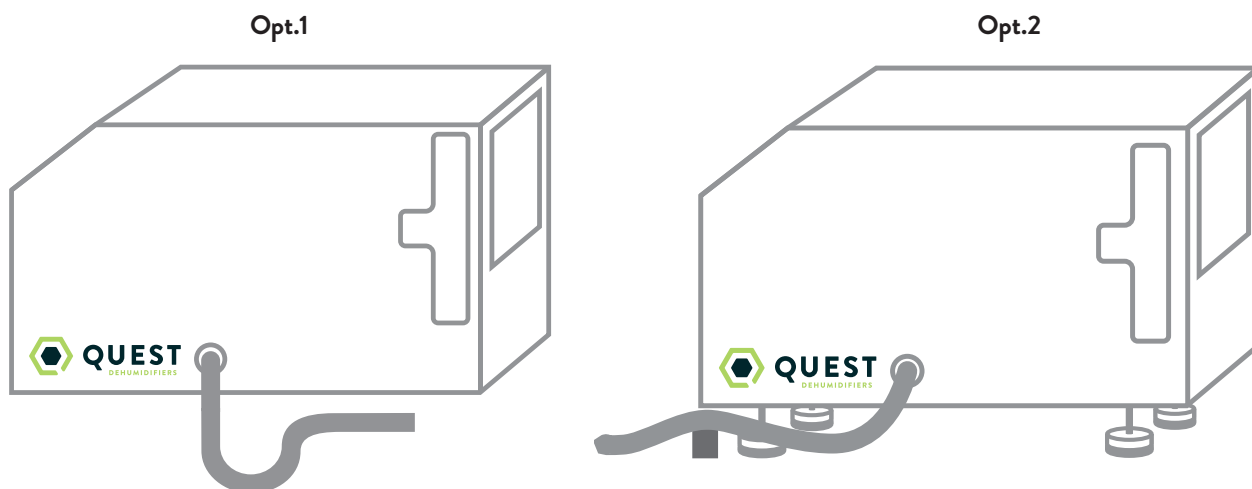

### 5.1 D Hanging Diagram

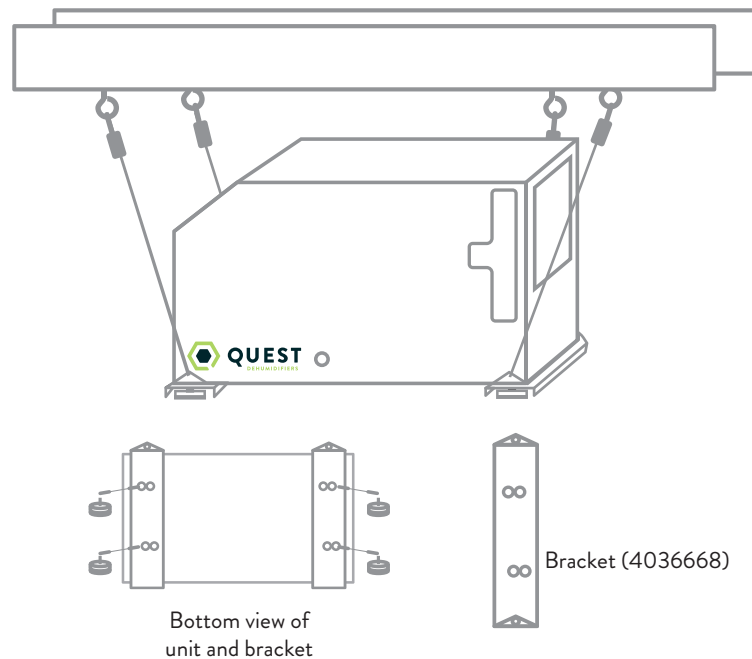

### 5.1 E Ducting

#### Supply Duct Kit (P/N 4028607)

A factory designed supply duct kit can be purchased to accept 10" ducting to both outlets of the Quest 185 Cool. Contact your dealer or call 1-877-420-1330 to order or go to [www.questhydro.com/product-category/accessories](http://www.questhydro.com/product-category/accessories).

#### Return Duct Kit (P/N 4028610)

A factory designed return duct kit can be purchased to accept 12" ducting. Contact your dealer or call 1-877-420-1330 to order or go to [www.questhydro.com/product-category/accessories](http://www.questhydro.com/product-category/accessories).

## 5.2 Condenser Setup

### 5.2 A Location

- The condensing unit is designed to be installed outdoors in a space that is protected from extreme weather (rain, wind, etc.). Do not place the condensing unit in direct sunlight.
- Place the condensing unit at least 1" above ground level.
- Place the condensing unit as close as possible to the dehumidifier to minimize the length of the connecting lines. The maximum line set length is 50 feet.
- Ensure the mounting of the condensing unit can withstand strong winds and earthquakes when mounting above ground level.
- The condensing unit may be mounted to a wall (with brackets) or placed on a roof.
- Mount the base of the condensing unit to a sturdy level pad (or bracket) using 3/8" (10mm) bolts.
- Avoid directing the discharge air at people.
- If used near a water source; be certain there is no chance the dehumidifier could fall into the water or get splashed and that it meets NEC standards.

- DO NOT use the condensing unit as a bench or table.
- Do not place the condensing unit where the sound and vibration caused by running the unit will cause a nuisance. Vibration dampening material may be installed between the condensing unit base and the mounting pad if required.
- Allow sufficient clearance to handle the unit's overall dimensions.
- Place the condensing unit where there is adequate space for the unit and the air required by the unit.
- Install the condensing unit with space to access the top and side panels for maintenance and service.

### 5.2 B Electrical Requirements

The condensing unit requires a dedicated 120Vac 20 Amp circuit capacity. Install a properly sized branch circuit disconnect (20 Amp) within sight of the unit. The Installer must supply the power wiring for the condensing unit. The power wiring must have a Minimum Circuit Ampacity of 20A and be run within a rain-tight conduit. The condensing unit must be grounded as required by applicable code(s).

#### Field Wiring the Condensing Unit:

1. Take off the panel (top), by removing the one screw that secures it to the condensing unit.
2. Loosen the two strain relief block screws.
3. Insert the power and control wires through the strain relief block.
4. Connect the power supply wires and control wires to the corresponding terminals on the terminal board.
5. Ground the condensing unit in accordance with local and national electrical codes.
6. Secure the power and control wires to the strain relief block by tightening the screws.
7. Reinstall the panel (top) by inserting the one screw that secures it to the condensing unit.

#### Condensing Unit Electrical Control Connections:

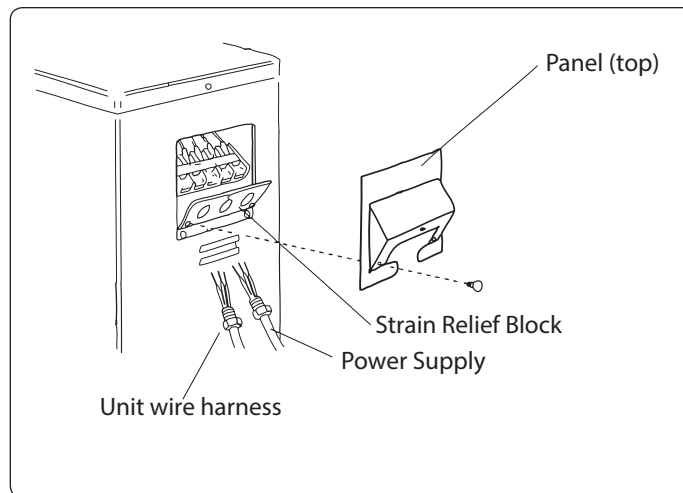

Connect the black control wire (8) from the dehumidifier to terminal N on the condensing unit terminal block.

Connect the black control wire (9) from the dehumidifier to terminal 1 on the condensing unit terminal block.



### 5.3 Line Set Installation

The installer must supply a line set (1/4" liquid line, 3/8" gas line) suitable for use with R410a refrigerant to connect the indoor unit to the outdoor unit. **The maximum allowable length of the line set is 50 feet.** The installer must braze the lines to the dehumidifier and the condensing unit. The gas (suction) line must be insulated to prevent the formation of condensation on the outside of the line.

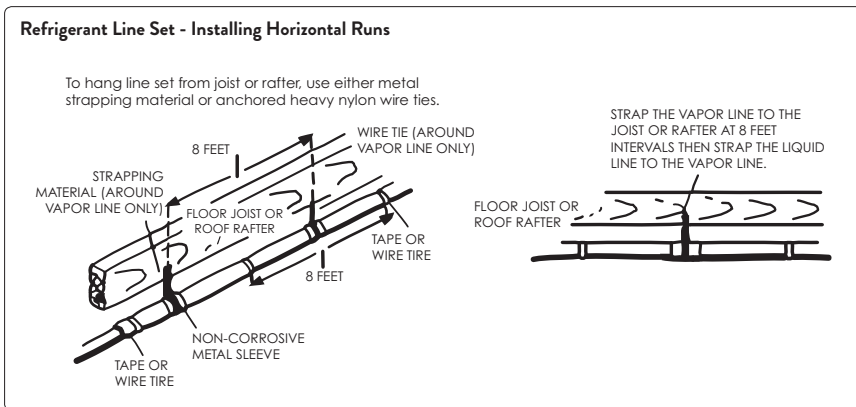
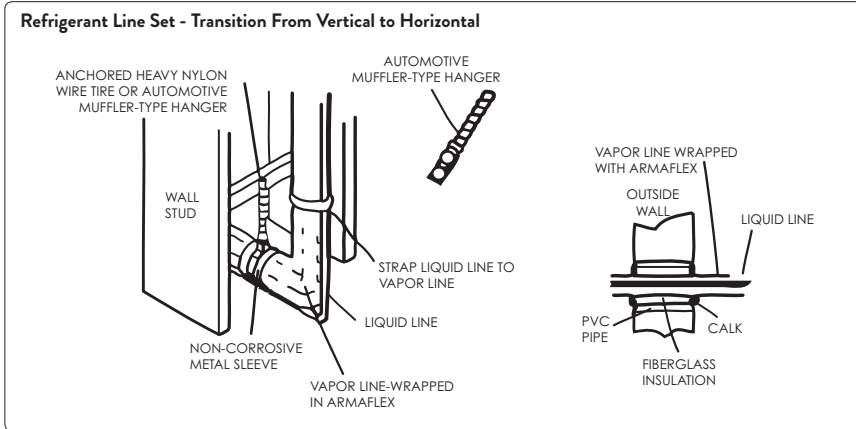

**When installing the line set:**

- Make sure the lines are suitable for use with R410a.
- Do not crush the lines and always allow a minimum bend radius of 2 inches.
- Keep the ends of the lines covered to prevent dirt and debris from entering the lines during installation.
- Secure the line set to the building with isolating hardware to prevent vibration transmission to the building.
- Seal and isolate the opening(s) where the line set is routed into the building.
- Insulate the gas (suction) line to prevent water condensation on the gas line.
- Flush the lines with an inert gas before and/or during brazing to prevent oxidation inside the lines.
- Release the inert gas holding charge and remove the plugs in the dehumidifier lines before brazing.
- Do not overheat the lines connected to the dehumidifier or the condensing unit when brazing.
- Be aware of the relative location of the dehumidifier (Indoor unit) and condensing unit (Outdoor Unit) when installing the line set.

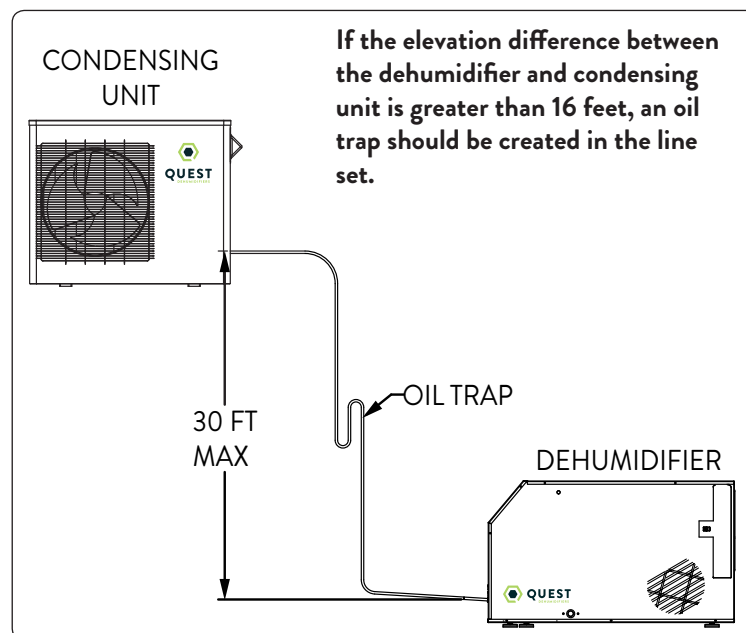
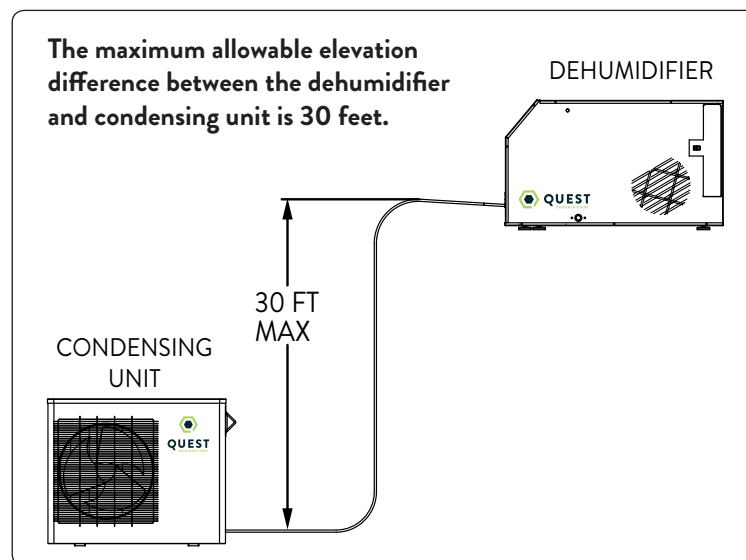

#### 5.4 Brazing the Line Set

##### WARNING!

Polyol ester (POE) oils used with HFC-410A refrigerant absorb moisture very quickly. It is very important that the refrigerant system be kept closed as much as possible. Do not remove line set caps or service valve stub caps until you are ready to make connections.

When using a high pressure gas such as dry nitrogen to pressurize a refrigeration or air conditioning system, use a regulator that can control the pressure down to 1 or 2 PSIG.

##### CAUTION!

Brazing alloys and flux contain materials which are hazardous to your health. Avoid breathing vapors or fumes from brazing operations. Perform operations only in well-ventilated areas. Wear gloves and protective goggles or face shield to protect against burns. Wash hands with soap and water after handling brazing alloys and flux.

To prevent stripping of the various caps used, the appropriately sized wrench should be used and fitted snugly over the cap before tightening.

Allow braze joint to cool before removing the wet rag from service valve. Temperatures above 250° can damage seals.

Use silver alloy brazing rods with 5% minimum silver alloy for copper-to-copper brazing. Use 45% minimum silver alloy for copper-to-brass and copper-to-steel brazing.

##### WARNING!

Fire, explosion and personal safety hazard. Failure to follow this warning could result in damage, personal injury or death. Never use oxygen to pressurize or purge refrigeration lines. Oxygen when exposed to a spark or open flame, can cause fire and/or an explosion, that could result in property damage, personal injury or death.

**Note:** There is a service port inside the dehumidifier (on the gas line) and both stub tubes of condensing unit. These service ports can be used to introduce and release nitrogen during brazing.

##### CAUTION!

The dehumidifier is shipped from the factory pressurized with a charge of inert gas and with rubber plugs in the lines. Purge the inert gas from the dehumidifier by removing the rubber plugs in the liquid and gas lines to release the inert gas before connecting the line set.

**Note:** If there is no pressure in the dehumidifier when the first plug is removed, check the dehumidifier for damage and leaks before continuing with the installation.

**Use the following procedure to connect the line set to the Dehumidifier:**

1. Purge the inert gas from the dehumidifier by removing the rubber plugs in the liquid and gas lines to release the inert gas before connecting the line set.
2. Place a field-provided heat shield, such as a wet rag, against the dehumidifier and around the piping stubs. The heat shield must be in place to protect the cabinet from heat damage.
3. Swage the liquid and gas lines (if necessary) to fit onto the dehumidifier lines.
4. Purge the dehumidifier lines and the line set with dry nitrogen (Inert gas) to prevent oxidation during brazing. Flow dry nitrogen into the lines at a low pressure of 1 to 2 psig.
5. Braze the line set lines to the dehumidifier lines.
6. Remove the heat shield after brazing and allow the connections to cool.

**Use the following procedure to connect the line set to the Condensing Unit:**

1. Cut the line set lines to the required length. Deburr the cut ends of the line set lines.
2. Fit the line stubs with flare fittings (included with the condensing unit) onto the line set if necessary.
3. Swage the liquid and gas lines (if necessary) to fit onto the line stubs with the flare fittings.
4. Remove service valve caps and cores.
5. Purge the lines with dry nitrogen (Inert gas) to prevent oxidation during brazing.
6. Braze the line set lines to the line stubs.
7. Apply a light coating of refrigeration oil to the flare fitting threads on the condensing unit valves.
8. Start each flare nut on the corresponding flare fitting on the condensing unit valves by hand, making sure the threads are properly engaged. Tighten the flare nuts hand tight.
9. Carefully torque the flare nuts to the corresponding flare fittings on the condensing unit valves.
  - Torque the liquid line flare nut to 13.3 ft-lbs.
  - Torque the suction line flare nut to 30.1 ft-lbs.
10. Reinstall service valve cores and caps.

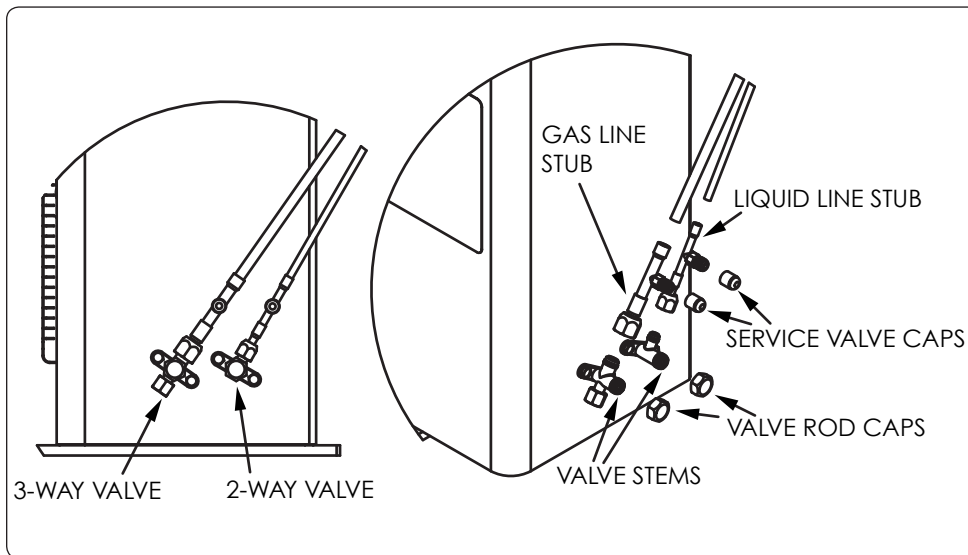

**Note:** Alternately, the stubs with the flare fittings can be connected to the condensing unit before brazing the line set. In this case a field provided heat shield, such as a wet rag, must be placed over the flare fittings and valves on the condensing unit to protect them from heat damage. The service valve cap and core should be removed before brazing near stub tubes.

### 5.5 Leak Test Line Set and Dehumidifier

#### Manifold Gage Set

When checking the system charge, use a manifold gage set that features low loss anti-blow back fittings. Manifold gage set used with HFC-410A refrigerant systems must be capable of handling the higher system operating pressures. The gages should be rated for use with high side operating pressures of 0 – 800 psig and low side operating pressures of 30 inches of vacuum to 250 psig. Dampened gages or anti-flutter gages are recommended. Gage hoses must be rated for use at up to 800 psig of pressure with a 4000 psig burst rating.

#### ⚠ CAUTION!

The environmental protection agency (EPA) prohibits the intentional venting of HFC refrigerants during maintenance, service, repair and disposal of appliance. Approved methods of recovery, recycling or reclaiming must be followed.

#### ⚠ WARNING!

When using a high pressure gas such as dry nitrogen to pressurize refrigeration or air conditioning system, use a regulator that can control the pressure down to 1 or 2 PSIG.

#### ⚠ CAUTION!

Leak detector must be capable of sensing HFC refrigerant.

#### ⚠ WARNING!

Refrigerant can be harmful if it is inhaled. Refrigerant must be used and recovered responsibly. Failure to follow this warning may result in personal injury or death.

1. Connect the HFC-410A manifold gage set high pressure hose to the service port on the suction gas line. **Note:**

Connecting the high pressure hose to the service port on the gas line will protect the manifold gage set from high pressure damage during leak testing. Cap liquid line service port.

2. Make sure all of the valves on the manifold gage set are closed. Connect a cylinder of HFC-410A refrigerant to the center port of the manifold gage set.
3. Position the HFC410A refrigerant cylinder to deliver vapor only. Open the valve on the HFC-410A refrigerant cylinder.
4. Open the high pressure side of the manifold gage set to allow HFC-410A into the line set and dehumidifier. Weigh in a trace amount of HFC-410A [A trace amount is a maximum of two ounces (57g) of refrigerant or 3 PSI]. Close the valve on the HFC-410A cylinder and the valve on the high pressure side of the manifold gage set.
5. Disconnect the HFC-410A refrigerant cylinder from the manifold gage set.
6. Connect a cylinder of dry nitrogen with a pressure regulating valve to the center port of the manifold gage set.

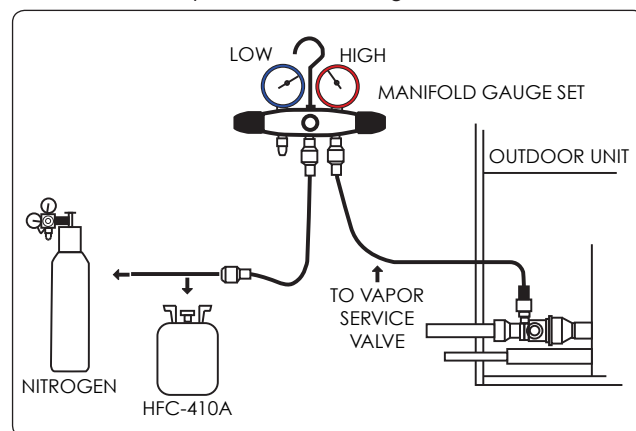

7. Adjust the dry nitrogen pressure regulator to 150 psig. Open the valve on the high pressure side of the manifold gage set to pressurize the line set and dehumidifier.
8. Close the valve on the dry nitrogen cylinder. Close the valve on the high pressure side of the manifold gage set.
9. Allow the system to rest for a few minutes.
10. Check all (brazed and threaded) joints for leaks using a leak detector designed to sense HFC refrigerants.
11. After leak testing is complete, disconnect the dry nitrogen cylinder from the center port of the manifold gage set and disconnect the high pressure hose of the manifold gage set from the suction gas line service port.

### 5.6 Evacuating the Line Set and The Dehumidifier

1. Remove the valve cores from the service ports on the liquid and gas line stubs using no-loss valve core removal tools.
2. Connect a 1/4" SAE in-line tee to the gas line stub valve core removal tool.
3. Connect the low pressure side of the manifold gage set to one of the ports on the 1/4" SAE in-line tee.
4. Connect a micron gage to the remaining port of the 1/4" SAE in-line tee.
5. Connect the high pressure side of the manifold gage set to the liquid line stub service port.
6. Connect a vacuum pump to the center port on the manifold gage set.
7. Open the valve core removal tool valves.
8. Open the high and low pressure sides of the manifold gage set and start the vacuum pump.
9. After evacuating for a few minutes, close the high and low pressure sides of the manifold gage set and observe the behavior of the micron gage. A rapid rise in the micron gage reading (pressure) indicates a leak in the system. If this occurs, check the manifold gage set, hoses, tee, and valve core removal tools for leaks. If no leak is found, repeat the leak test procedure on Page 15.
10. Evacuate the line set and dehumidifier for a minimum of 15 minutes and check that the micron gauge reads below 500 microns.
11. Close the low and high pressure sides of the manifold gage set and stop the vacuum pump.
12. Wait 10 minutes.
13. If the micron gage reading rises above 800 microns, check for leaks and return to step 9.
14. If the micron gage reading remains below 800, close the valves on the valve core removal tools.
15. Remove the tee from the gas line stub valve core removal tool. Connect the low pressure side of the manifold gage set to the gas line stub valve core removal tool.
16. Install the valve core into the liquid line stub service port.
17. Remove the vacuum pump from the center port of the manifold gage set and proceed to the next section to charge the system.

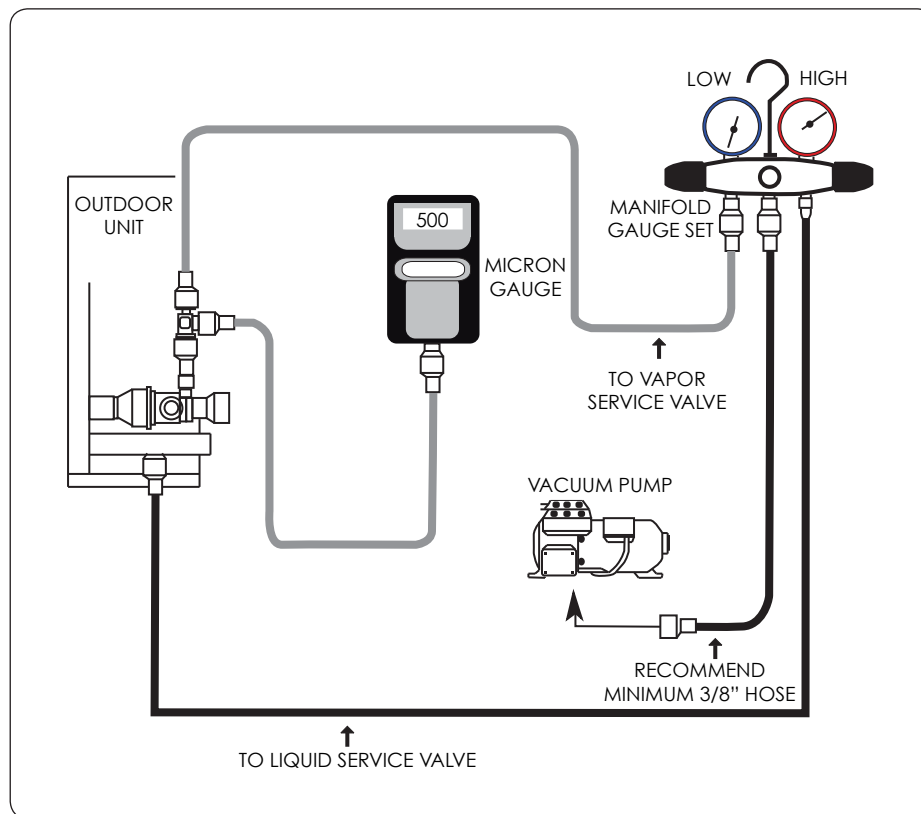

### 5.7 Charging the System

The condensing unit is pre-charged with 42 oz. of HFC-410A refrigerant. The installer will add HFC-410A refrigerant for the dehumidifier and line set.

1. Calculate the amount of HFC-410A required by determining the length of the line set and performing the calculation below:  
 $11\text{oz} + 2.2\text{oz per every 10 feet of line set length} = \text{Total charge required}$
2. Connect a cylinder of HFC-410A refrigerant to the center port of the manifold gage set. Position the HFC-410A refrigerant cylinder to deliver liquid only.
3. Open the valve on the HFC-410A cylinder.
4. Place the HFC-410A cylinder on a refrigerant scale and zero the scale.
5. Open the valve on the gas line stub valve core removal tool.
6. Open the low pressure side of the manifold gage set and weigh in the amount of HFC-410A calculated in step 1.
7. Close the valve on the HFC-410A cylinder and the low pressure side of the manifold gage set.

8. Close the valve on the gas line stub valve core removal tool.
9. Remove the high and low pressure sides of the manifold gage set from the valve core removal tools.
10. Install the valve core in the gas line stub port using the no-loss valve core removal tool
11. Remove the no-loss valve core removal tools from the service ports on the liquid and gas line stubs.
12. Install the caps on the service ports of the liquid and gas line stubs finger tight, then tighten an additional 1/6 turn. Check the service port caps for leakage – reinstall if necessary.

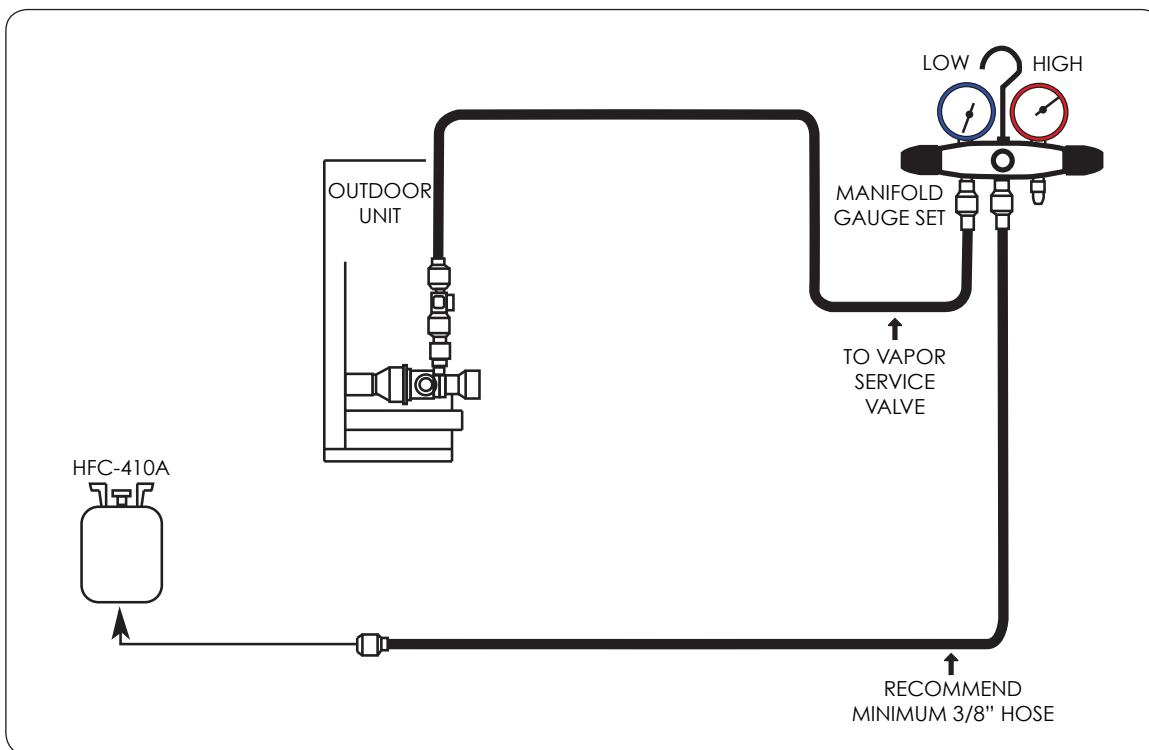
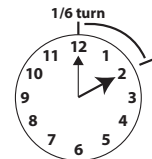

## 6. Control Options

The Quest 185 Cool Dehumidifier can be controlled by its on board dehumidistat or with an external control using its low voltage terminal block.

### 6.1 On board dehumidistat

The humidity control is an adjustable switch that closes when the relative humidity of the air in which it is located rises to the dial set point. It opens when the RH drops 4 to 6% below the set point.

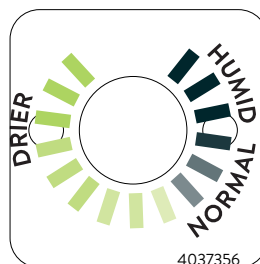



#### Approximate Humidity Levels Per Setting

“Dry”	20% to 30% Relative Humidity
“Normal”	50% Relative Humidity (Recommended)
“Humid”	80% to 90% Relative Humidity

The dehumidifier will run until the relative humidity (RH) is reduced to the humidity control dial setting.

## 6.2 External Control

The Quest 185 Cool Dehumidifier is controlled using five terminals.

COM = 24volt AC power transformer neutral side (common with white)

FAN = Fan control

24V = transformer high side

DEHU = Dehumidification (fan and compressor) control

DMPR = 24volt AC power transformer neutral side (common with red)

\* On board dehumidistat must be set to off, otherwise the dehumidifier will run at the lowest setpoint between the dehumidistat and external control.

Between the COM/DMPR lead and the 24V leads is a 40VA transformer. This low voltage power source powers the relay coils which control the fan and compressors. This 24VAC transformer can also be used to power HVAC accessories external to the dehumidifier.

- To turn the dehumidifier on, make contact between 24V and DEHU terminals or turn the dehumidistat clockwise towards drier.
- To turn the fan on, make contact between 24V and FAN terminals.
- To power a 24V HVAC accessory, connect the accessory to the COM terminal and the 24V terminal.

**NOTE: 18 ga wire needed between the Quest 185 Cool dehumidifier and the external control**

**Quest offers two external control options**

6.2 A DEH 3000R

4028531

QUEST DEH 3000R CONTROL WIRING DIAGRAM

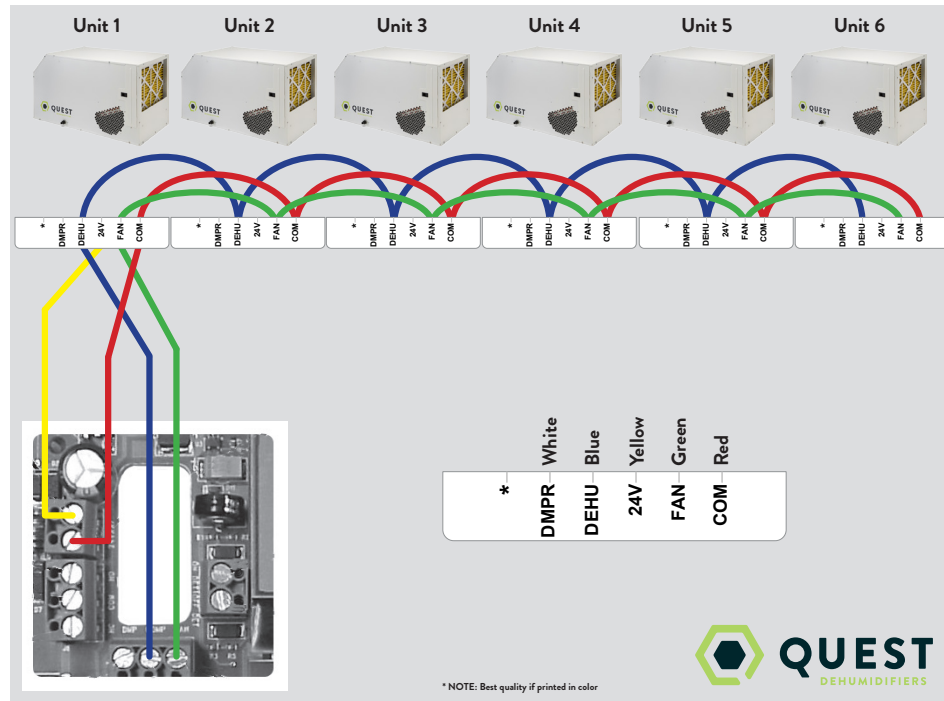
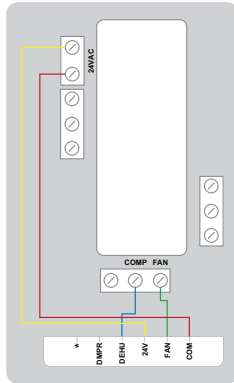

Quest recommends a maximum of 6 dehumidifiers linked together.

NOTE: 22 ga wire needed for sensor

Contact your dealer or call 1-877-420-1330 to order or go to [www.questhydro.com/product-category/accessories](http://www.questhydro.com/product-category/accessories).

6.2 B Honeywell Remote Humidistat

4020175

HONEYWELL REMOTE HUMIDISTAT WIRING DIAGRAM

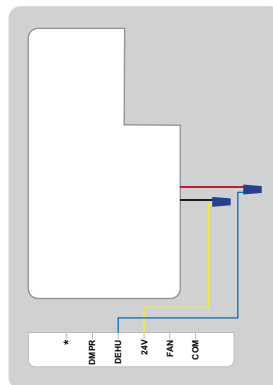

7. Maintenance

**⚠ WARNING! NOTE: Do not operate the unit without the filter or with a less effective filter. The heat exchange coils inside the unit could become clogged and require disassembly to clean. Filter non-compliance invalidates the product warranty.**

### 7.1 Standard Air Filter

The Quest 185 Cool Dehumidifier ships with a standard MERV 11 efficient pleated fabric filter. This filter should be checked every six months. Operating the unit with a dirty filter will reduce dehumidifier capacity and efficiency and may cause the compressor to cycle off and on unnecessarily on the defrost control.

To access the air filter, remove the filter access panel from the end of the Quest 185 Cool Dehumidifier. The filter should be readily visible and can be removed by pulling it straight out of the Quest 185 Cool Dehumidifier.

We recommend changing the filter at least with every grow cycle.

### 7.2 Impeller Fan Oiling

The impeller fan motor is factory lubricated for many years of normal operation, and no further oiling is required.

## 8. Service

### 8.1 Warranty

A warranty certificate has been enclosed with this unit; read it before any repair is initiated. If a warranty repair is required, call the factory first at 1-877-420-1330 for warranty claim authorization and technical assistance.

### 8.2 Refrigerant Charging

#### WARNING!

**Servicing the Quest 185 Cool with its high pressure refrigerant system and high voltage circuitry presents a health hazard which could result in death, serious bodily injury, and/or property damage. Service must be performed by a qualified service technician.**

If the refrigerant charge is lost due to service or a leak, the leak should be repaired and a new charge must be accurately weighed in. If any of the old charge is left in the system, it must be recovered before weighing in the new charge. Refer to the unit nameplate for the correct charge weight and refrigerant type.

### 8.3 Service Parts List - Dehumidifier

Item	Part No.	Description
1	4021475	Air Filter 16"x20"x2" MERV-11
2	4026221	Foot, Leveling, 5/16-18
3	4031086-05	Evaporator Coil
4	4029510	Filter/Drier
5	4025741	Thermostat, Defrost Control
6	4029508	Low Pressure Switch
7	4026657	Impeller
8	4035235-07	Blower Capacitor, Run, 15 MFD, 370V, Dry
9	4020924	Blower Relay, SPDT, 24V, 15A
10	4022487	Transformer

### 8.4 Service Parts List - Condensing Unit

Item	Part No.	Description
1	4033211	Nut
2	4033212	Fan-Axial
3	4033213	Compressor
4	4033214	Capacitor
5	4033216	Capacitor-Fan Motor
6	4033215	Motor
7	4022484	Relay

### 8.5 Troubleshooting

#### CAUTION!

**Troubleshooting should be performed by a qualified HVAC technician.**

**Neither fan nor compressor running. Dehumidification is being called for.**

1. Dehumidifier unplugged or no power to outlet.
2. Humidity control set too high.
3. Loose connection in internal or control wiring.
4. Defective compressor relay.
5. Defective control transformer.

**Compressor is not running. Dehumidification is being called for. Fan is running.**

1. Defective compressor run capacitor.
2. Loose connection in compressor circuit.
3. Defective compressor overload.
4. Defective compressor.
5. Defrost thermostat open.

**Compressor cycles on and off. Dehumidification is being called for.**

1. Low ambient temperature and/or humidity causing unit to cycle through defrost mode.
2. Defective compressor overload.
3. Defective compressor.
4. Defrost thermostat defective.
5. Dirty air filter(s) or air flow restricted.
6. Defective fan or relay.

**Fan is not running. Dehumidification or fan is being called for.**

1. Loose connection in fan circuit.
2. Obstruction prevents fan impeller rotation.
3. Defective fan.
4. Defective fan relay.

**Low dehumidification capacity (evaporator is frosted continuously). Dehumidification is being called for.**

1. Defrost thermostat loose or defective.
2. Low refrigerant charge.
3. Dirty air filter(s) or air flow restricted.
4. Excessively restrictive ducting connected to unit.

**No ventilation. Ventilation is being called for.**

1. Loose connection in ventilation control circuit.
2. Loose connection in damper power circuit.
3. Defective fresh air damper.

**Dehumidifier removes some water, but not as much as expected.**

1. Air temperature and/or humidity have dropped.
2. Humidity meter and or thermometer used are out of calibration.
3. Unit has entered defrost cycle.
4. Dirty air filter(s) or air flow is restricted.
5. Defective defrost thermostat.
6. Low refrigerant charge.
7. Air leak such as loose cover or ducting leaks.
8. Defective compressor.
9. Restrictive ducting.

### **Troubleshooting Procedure for Control Related Issues.**

This method of diagnosis will test the 3 main components of the control circuit individually to indicate any potential problems. This is to be used when the control will not activate the main unit.

1. Detach field control wiring connections from the pigtails on the main unit.
2. Connect the yellow and green wire pigtails together; only the fan should run. Disconnect the wires.
3. Connect the yellow and blue wires pigtails together; fan and compressor should run. Disconnect the wires.
4. If this test works, the main unit is working correctly from a control standpoint.
5. Reconnect field control wiring to the pigtails on the main unit.
6. Remove the control panel cover and detach the field wiring from the control connections.
7. Connect the yellow and green wires together; only the fan should run. Disconnect the wires.
8. Connect the yellow and blue wires together; fan and compressor should run. Disconnect the wires.
9. If this test works, then the field control wiring is ok.
10. If the problem persists, then the control is most likely faulty.

**Troubleshooting Procedure for Performance Related Issues.**

This method of diagnosis is used to function check the internal components in the dehumidifier. This is to be used when a performance issue is suspected.

1. Set the humidity controller all the way to the most humid setting or off position – Did the unit shut off?
2. If yes, turn the fan setting to the ON position – does the fan start?
3. If fan starts, leave in the fan ON position and set the humidity all the way to driest setting. May have to wait 5 minutes for the compressor to start.
4. Listen for a distinct buzzing/humming sound of a compressor starting up – do you hear this noise?
5. If compressor is running and continues to run, after about 15 minutes you should feel a slight increase in air temperature being discharged out of the discharge air side of the unit.
6. If so, depending on your environmental conditions (temp/Rh%), you should see some water production out of the hose within 30 minutes or so. (Note: If the room temperature is 55 degrees or below and/or in area of low relative humidity, the dehumidifier will produce little to no water.)
7. Collecting the water removed in a 24 hour period will give a measurement of performance.

**9. Wiring Diagrams**

**9.1 Dehumidifier Wiring Diagram**

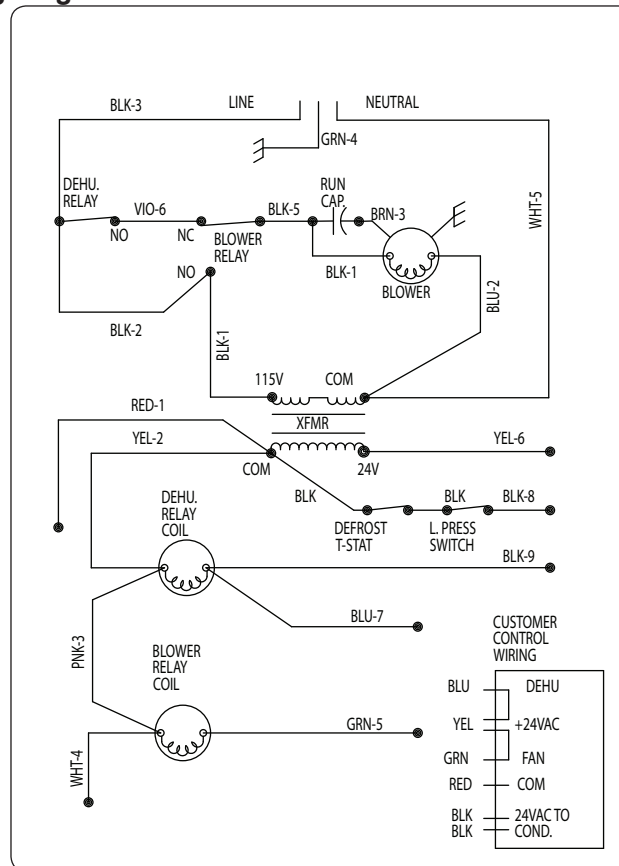

9.2 Condenser Wiring Diagram

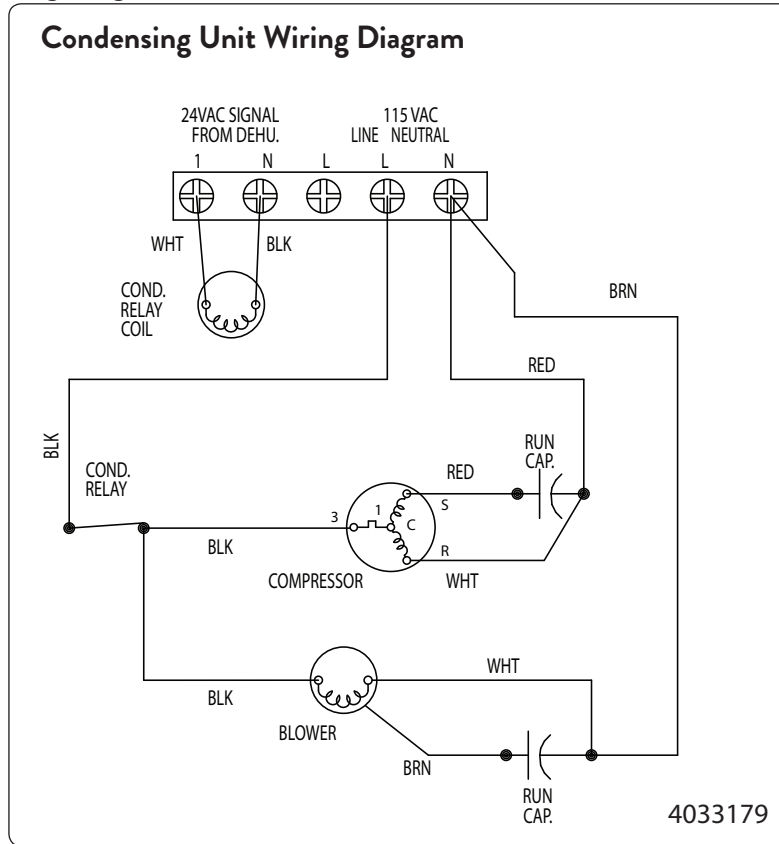

9.3 Dehumidifier and Condenser Wiring Diagram

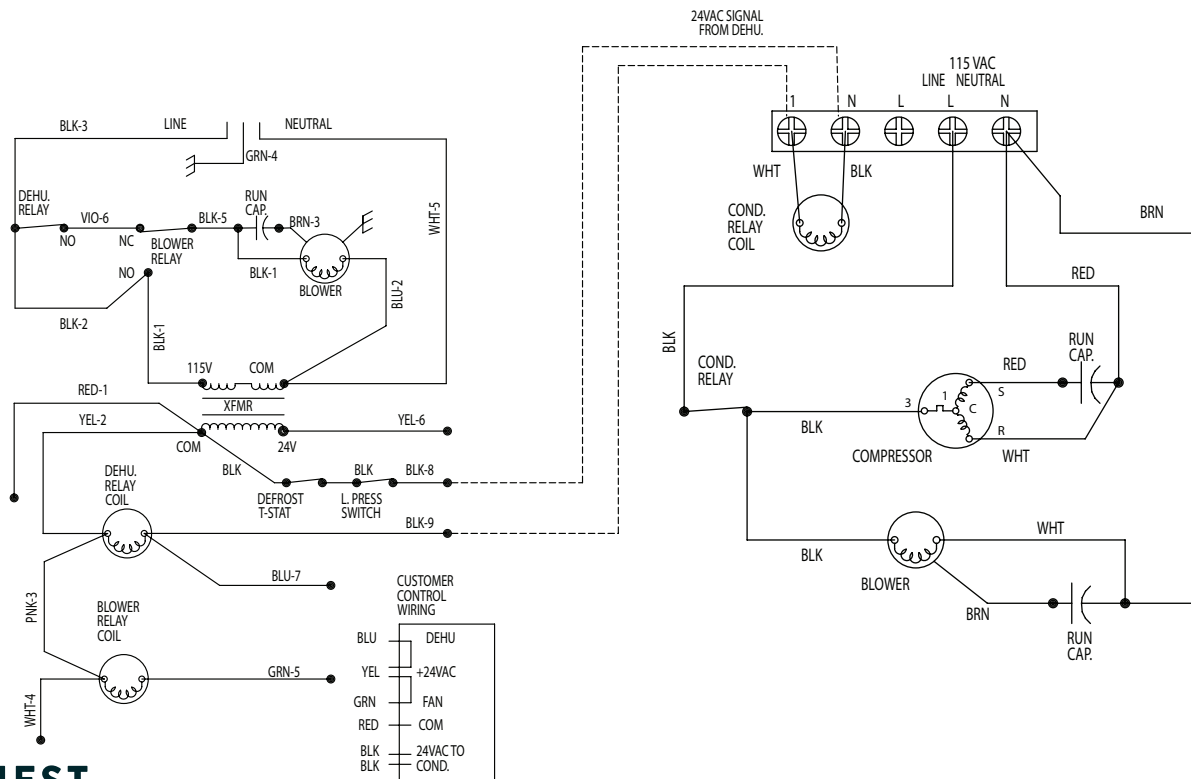

### 10. Optional Accessories

PART NO.	DESCRIPTION
4028531	DEH 3000R Control (with remote)
4021475	MERV 11 Filter (16"x20"x2")
4028614	Pump Kit
4036685	Hang Kit



**Limited Warranty.** Therma-Stor, LLC (“Therma-Stor”) warrants as follows: (i) the Quest 185 Cool dehumidifier (“Product”) will be free of material defects in workmanship or materials for a period of one (1) year (“One-Year Warranty”) following the date of initial purchase of such Product by an original customer purchasing from Therma-Stor or an authorized reseller (“Customer”); and (ii) the Product’s condenser, evaporator, and compressor will be free of material defects in workmanship or materials for a period of five (5) years following the date of initial purchase of such Product by a Customer.

**Limitation of Remedies.** CUSTOMER’S SOLE AND EXCLUSIVE REMEDY UNDER THE ABOVE LIMITED WARRANTY AND THERMA-STOR’S ENTIRE LIABILITY THEREUNDER, SHALL BE, AT THE SOLE OPTION OF THERMA-STOR, REPLACEMENT OR REPAIR OF SUCH PRODUCT OR ITS COMPONENTS (“COMPONENTS”) BY THERMA-STOR OR THERMA-STOR’S AGENTS ONLY. REFRIGERANT, PIPING, SUPPLIES, TRANSPORTATION COSTS, LABOR COSTS INCURRED IN REPAIR OR REPLACEMENT OF SUCH COMPONENTS ARE NOT INCLUDED. THIS DISCLAIMER AND EXCLUSION SHALL APPLY EVEN IF THE EXPRESS WARRANTY AND LIMITED REMEDY SET FORTH HEREIN FAILS OF ITS ESSENTIAL PURPOSE. CUSTOMER ACKNOWLEDGES THAT NO REPRESENTATIVE OF THERMA-STOR OR OF ITS AFFILIATES OR RESELLERS IS AUTHORIZED TO MAKE ANY REPRESENTATION OR WARRANTY ON BEHALF OF THERMA-STOR OR ANY OF ITS AFFILIATES OR RESELLERS THAT IS NOT IN THIS AGREEMENT. Notwithstanding the above, during the term of the One-Year Warranty only, Therma-Stor will provide, free of charge to Customer, all Components and labor (except costs related to removal and installation of Product) required to fulfill its obligations under such One-Year Warranty.

**Disclaimer of Warranties.** EXCEPT FOR ABOVE LIMITED WARRANTY, WHICH IS THE SOLE AND EXCLUSIVE WARRANTY PROVIDED WITH RESPECT TO THE PRODUCT AND ITS COMPONENTS, THERMA-STOR HEREBY DISCLAIMS ALL EXPRESS AND IMPLIED WARRANTIES, INCLUDING, WITHOUT LIMITATION, THE IMPLIED WARRANTIES OF MERCHANTABILITY AND FITNESS FOR A PARTICULAR PURPOSE.

**Warranty Limitations.** The foregoing limited warranty extends only to a Customer and shall be null and void upon attempted assignment or transfer. A “defect” under the terms of the limited warranty shall not include problems resulting from Customer’s or Customer’s employees’, agents’, invitees’ or a third party’s misuse, improper installation, improper design of any system in which the Product is included, abuse, lack of normal care, failure to follow written instructions, tampering, improper repair, or freezing, corrosion, acts of nature or other causes not arising out of defects in Therma-Stor’s workmanship or material. If a Product or Component is replaced while under warranty, the applicable limited warranty period shall not be extended beyond the original warranty time period. The limited warranty does not cover any costs related to changes to a Product or Component that may be required by any codes, laws, or regulations that may become effective after initial purchase of the Product by Customer.

**Customer Responsibilities.** As a further condition to obtaining warranty coverage hereunder, the Customer must send a valid warranty claim to Therma-Stor such that Therma-Stor receives such claim prior to the end of the applicable warranty period. Therma-Stor shall have no obligation hereunder with respect to any claim received by Therma-Stor after the expiration of the applicable warranty period. As a further condition to obtaining warranty coverage hereunder, the Customer must present forms of invoices evidencing proof of purchase of a Product. If such invoices do not clearly indicate the date of initial purchase by a Customer, the applicable Product’s date of manufacture will be used instead of the date of initial purchase for the purpose of calculating the commencement of the applicable warranty period. Warranty service must be performed by Therma-Stor or a servicer authorized by Therma-Stor. In order to obtain warranty service, the Customer should call Therma-Stor at 1-800-533-7533 and ask for the Therma-Stor Products Service Department, which will then arrange for applicable warranty service. Warranty service will be performed during customary, daytime working hours. If the Product must be shipped for service, Customer shall be solely responsible for properly packaging the Product, for all freight charges, and for all risk of loss associated with shipment.

**Limitation of Liability.** IN NO EVENT SHALL THERMA-STOR, IN CONNECTION WITH THE DESIGN, SALE, INSTALLATION, USE, REPAIR, REPLACEMENT OR PERFORMANCE OF ANY PRODUCT, COMPONENT, PART THEREOF OR WRITTEN MATERIAL PROVIDED THEREWITH, BE LIABLE, TO THE EXTENT ALLOWED UNDER APPLICABLE LAW, UNDER ANY LEGAL THEORY FOR ANY SPECIAL, DIRECT, INDIRECT, COLLATERAL OR CONSEQUENTIAL DAMAGES OF ANY KIND. NOTWITHSTANDING THE ABOVE LIMITATIONS AND WARRANTIES, THE SOLE AND EXCLUSIVE LIABILITY OF THERMA-STOR, REGARDLESS OF THE NATURE OR THEORY OF THE CLAIM, SHALL UNDER NO CIRCUMSTANCES EXCEED THE PURCHASE PRICE OF THE PRODUCT, COMPONENT OR PART UPON WHICH THE CLAIM IS PREMISED.

**Applicable Law and Venue.** ANY ARBITRATION, ENFORCEMENT OF AN ARBITRATION OR LITIGATION RELATED TO THE PRODUCT WILL BE BROUGHT EXCLUSIVELY IN DANE COUNTY, WISCONSIN, AND CUSTOMER CONSENTS TO THE JURISDICTION OF THE FEDERAL AND STATE COURTS LOCATED THEREIN, SUBMITS TO THE JURISDICTION THEREOF AND WAIVES THE RIGHT TO CHANGE VENUE. CUSTOMER FURTHER CONSENTS TO THE EXERCISE OF PERSONAL JURISDICTION BY ANY SUCH COURT WITH RESPECT TO ANY SUCH PROCEEDING.

**Miscellaneous.** If any term or condition of this Limited Warranty is found by a court of competent jurisdiction to be invalid, illegal or otherwise unenforceable, the same shall not affect the other terms or conditions hereof or thereof or the whole of this Limited Warranty. Any delay or failure by Therma-Stor to exercise any right or remedy will not constitute a waiver of Therma-Stor to thereafter enforce such rights.