

# Quest 165 and 225 Dual

## Installation, Operation and Maintenance Instructions

### – Read and Save These Instructions –

*This manual is provided to acquaint you with the dehumidifier so that installation, operation and maintenance can proceed successfully. Ultimate satisfaction depends on the quality of installation and a thorough understanding of this equipment. The dehumidifier is built around tested engineering principles and has passed a thorough inspection for quality of workmanship and function.*

#### Features:

- 230V, 60Hz
- Industry-leading efficiency
- Patented, optimized air-to-air heat exchanger
- High-efficiency, long-life impeller fan
- Quiet operation
- Superior air filtration (MERV-11 standard)
- Auto-restart after power outages
- Environmentally friendly R410A refrigerant
- Low voltage control



PATENTS:  
D570,988  
8,069,681  
9,052,132

#### Water Removal Rates (Pints/Day) @ 80°F 60% (RH)

Dehumidifier	Pints Removed	Gallons/Liters
165 Dual	155	19.4/73.3
225 Dual	225	28.1/106.6



4201 Lien Rd  
Madison, WI 53704  
[www.QuestClimate.com](http://www.QuestClimate.com)

Toll-Free 1-877-420-1330  
[info@QuestClimate.com](mailto:info@QuestClimate.com)

**Table of Contents**

Safety Precautions ..... 3

1. Intended Application ..... 4

2. Registrations ..... 4

3. Specifications ..... 4

4. Installation ..... 5

    4.1 Location ..... 5

    4.2 Electrical Requirements..... 5

    4.3 Condensate Removal ..... 6

    4.4 Install Diagram..... 6

    4.5 Ducting ..... 7

        4.5A Supply Duct Kit ..... 7

        4.5B Return Duct Kit ..... 7

5. Controls ..... 7

    5.1 On board dehumidistat ..... 7

    5.2 External Control ..... 8

        5.2A Deh 3000R ..... 8

        5.2B Honeywell Remote Humidistat ..... 9

6. Maintenance ..... 9

    6.1 Standard Air Filter ..... 9

    6.2 Impeller Fan Oiling ..... 9

7. Service ..... 9

    7.1 Warranty ..... 9

    7.2 Technical description..... 10

    7.3 Troubleshooting..... 10

    7.4 Refrigerant Charging ..... 12

    7.5 Impeller Fan Replacement ..... 12

    7.6 Compressor/Capacitor Replacement ..... 12

        7.6A Checking Compressor Motor Circuits ..... 12

        7.6B Replacing Burned Out Compressor ..... 13

        7.6C Replacing Compressor-Nonburn Out ..... 13

    7.7 Remote Controls..... 13

        7.7A Humidity Control ..... 14

    7.8 Defrost Thermostat ..... 14

    7.9 Electric Ventilation Damper ..... 14

    7.10 Condensate Pump Kit..... 14

Wiring Diagram ..... 15

Service Parts List ..... 16

Optional Parts List ..... 16

Warranty ..... 17



## Safety Precautions

Read the installation, operation and maintenance instructions carefully before installing and operating this device. Proper adherence to these instructions is essential to obtain maximum benefit from your **Quest Dual** Dehumidifier.

## READ AND SAVE THESE INSTRUCTIONS

- The device is designed to be installed **INDOORS IN A SPACE THAT IS PROTECTED FROM RAIN AND FLOODING.**
- Install the unit with space to access the back or side panels for maintenance and service. **DO NOT INSTALL UNIT WITH THE SERVICE PANELS INACCESSIBLE.**
- Avoid directing the discharge air at people, or over the water in pool areas.
- If used near a pool, spa or water; be certain there is **NO** chance the unit could fall into the water, be splashed and that it is plugged into an outlet that is a **GROUND FAULT INTERRUPT** protected circuit.
- **DO NOT** use the device as a bench or table.
- **DO NOT** place the device directly on structural members. Provide vibration isolation in order to minimize operational vibration and/or noise.
- A drain pan **MUST** be placed under the unit if installed above a living area or above an area where water leakage could cause damage
- Never operate a unit with a damaged power cord. If the power cord is damaged it must be replaced by the manufacturer, its service agent, or similarly qualified person in order to avoid a hazard.
- Make all electrical connections in accordance with the current edition of the **NEC ANSI/NFPA 70** and any national and local codes or ordinances that may apply.
- Maintain a minimum 1ft. (.3m) clearance to avoid obstructing the air return and supply.
- This appliance is not intended for use by persons (including children) with reduced physical, sensory or mental capabilities, or lack of experience and knowledge, unless they have been given supervision or instruction concerning use of the appliance by a person responsible for their safety. Children should be supervised to ensure that they do not play with the appliance.

### 1. Intended Application for Quest Dual Dehumidifier



The Quest Dual Dehumidifier is designed to operate in temperatures between 56° and 95°F.

In order to efficiently control humidity levels, the area in which the dehumidifier is to be operated must be free of water intrusion or excessive fresh (outside) air infiltration. Before installing the Quest Dual Dehumidifier, water intrusion and air infiltration problems should be addressed or noted in calculations.

### 2. Registrations

The Quest Dual Dehumidifier units conform to unified standard UL 60335-2-40.

### 3. Specifications @ 80°F/60% RH

Unit:	4037410 165 Dual	4035400 225 Dual
<b>Blower:</b> (Tested with duct collars on)	391 CFM @ 0.0" WG 363 CFM @ 0.2" WG 337 CFM @ 0.4" WG	526 CFM @ 0.0" WG 495 CFM @ 0.2" WG 458 CFM @ 0.4" WG
<b>Power (Watts):</b>	980	1500
<b>Supply voltage:</b>	220-240 VAC - 1 Phase - 60 Hz.	220-240 VAC - 1 Phase - 60 Hz.
<b>Current Draw (Amps):</b>	3.5	6.9
<b>Energy Factor: (L/kWh)</b>	3.7	2.9
<b>Operating Temp:</b>	56°F - 95°F	56°F - 95°F
<b>Water Removal (Pints/Day):</b> <b>Efficiency (Pints/kWh):</b>	155 7.8	225 6.1
<b>Air Filter (MERV-11 Nominal):</b>	Size: 16" x 20" x 2"	Size: 16" x 20" x 2"
<b>Power Cord:</b> 10' 14/3 SJTW	NEMA w/6-15P Plug 	NEMA w/6-15P Plug 
<b>Drain Connection:</b>	3/4" Threaded NPT	3/4" Threaded NPT
<b>Refrigerant Type:</b> <b>Refrigerant Amount:</b>	R410A 2lb. 0oz.	R410A 2lb. 0oz.
<b>Dimensions:</b>	Unit      Shipping	Unit      Shipping
<b>Width:</b>	20.25"    25"	20.25"    25"
<b>Height:</b>	21.75"    29"	21.75"    29"
<b>Length:</b>	37.88"    42"	37.88"    42"
<b>Weight:</b>	140 lbs    160 lbs	160 lbs    180 lbs

\* Requires buck/boost transformer to run on 208V or 277V

## 4. Installation

### 4.1 Location

The Quest Dual Dehumidifier can be installed in a variety of locations to meet the owner's needs as listed below. In all cases keep the following cautions in mind:

- It is designed to be installed **INDOORS IN A SPACE THAT IS PROTECTED FROM RAIN AND FLOODING.**
- Install the unit with space to access the back and side panels for maintenance and service and also to allow easy access to the filter cover panel. **DO NOT INSTALL UNIT WITH THE FRONT PANEL OR FILTER COVER PANEL INACCESSIBLE.**
- Avoid discharging the air directly at people, or over the water in pool areas.
- Be certain there is **NO** chance the unit could fall into water or be splashed and that it is plugged into a **GROUND FAULT INTERRUPTER.**
- **DO NOT** use the Quest Dual Dehumidifier as a bench or table.
- **DO NOT** place the Quest Dual Dehumidifier directly on structural members. Provide vibration isolation in order to minimize operational vibration and/or noise.
- A drain pan **MUST** be placed under the unit if installed above an area where water leakage could cause damage.
- Maintain a minimum 1ft. (.3m) clearance to avoid obstructing the air return and supply.
- Place the Quest Dual Dehumidifier on supports that raise the base of the unit 2.5" above the drain pan to a P-trap can be installed. See Section 4.3.
- The Quest Dual Dehumidifier may be suspended with steel hanger, straps, or a suitable alternative from structural members, unit must be supported from underneath. Don't hang from sides or ends. See section 4.4

### 4.2 Electrical Requirements

The Quest Dual Dehumidifier plugs into NEMA rated Receptacles. The amp draws for each unit under normal operating conditions are listed on page 4. A ground fault interrupter protected circuit is required.

Install the remote control panel in a central area of the structure where it will sense the relative humidity of the structure accurately. Do not install the control panel where it may not accurately sense the relative humidity such as near HVAC supply registers, near exterior doors, or near a pool or spa. The installer must supply the wiring between the Quest Dual Dehumidifier and the control panel. Be sure to safely route the control wiring to prevent damage during installation. Be careful not to cross the wires when connecting the Quest Dual Dehumidifier and the remote control panel.

The remote controls of the Quest Dual Dehumidifier are powered by a low voltage circuit (24 VAC) and must **NEVER** contact or be connected to a high voltage circuit. The control terminals and remote control are labeled and numbered to prevent confusion. Be sure to consult the electrical schematic in this manual or inside the access panel of the Quest Dual Dehumidifier before making the control connections.

**⚠ CAUTION!** For proper drainage, the unit must be mounted so the drain outlet is at least 4” above the floor drain, and must be fully supported under the base.

### 4.3 Condensate Water Removal

Condensate drains by gravity via the drain port. Use 3/4” male NPT PVC pipe. An optional condensate pump kit may be installed if a lift is required to dispose of the condensate. Optional parts list for information on the kit.

Follow Diagram

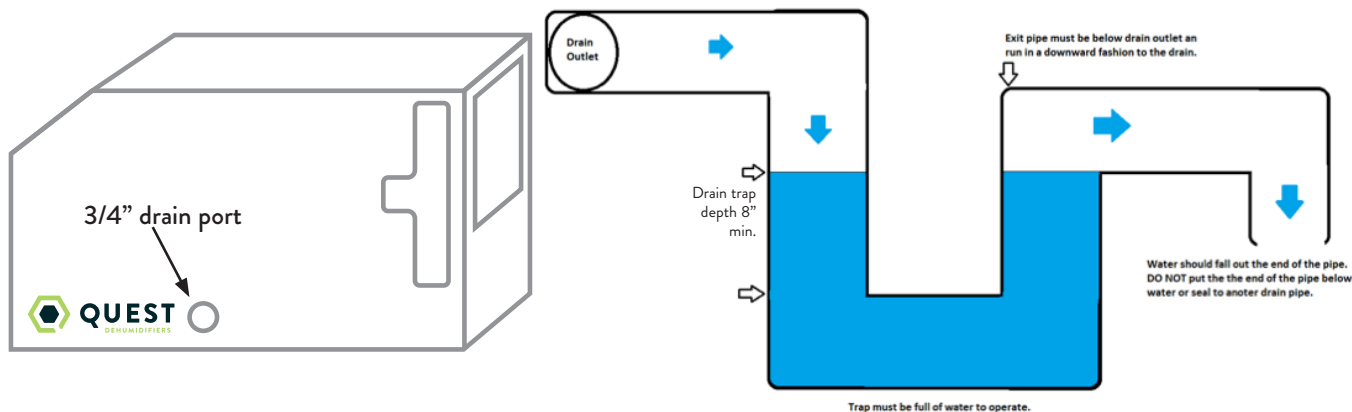

### 4.4 Hanging Diagram

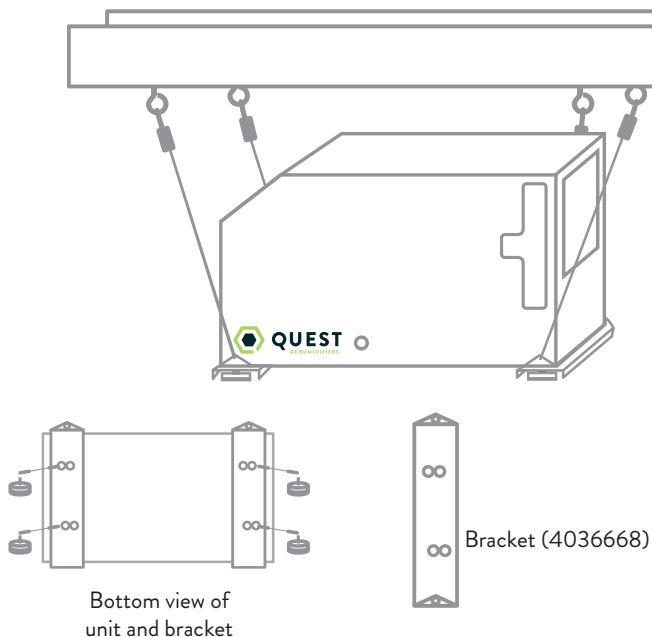

## 4.5 Ducting

### 4.5A Supply Duct Kit (P/N 4028607)

A factory designed supply duct kit can be purchased to accept 10” ducting to both outlets of the Quest Dual. Contact your dealer or call 1-877-420-1330 to order or go to [www.questclimate.com/product-category/accessories](http://www.questclimate.com/product-category/accessories).

### 4.5B Return Duct Kit (P/N 4028610)

A factory designed return duct kit can be purchased to accept 12” ducting. Contact your dealer or call 1-877-420-1330 to order or go to [www.questclimate.com/product-category/accessories](http://www.questclimate.com/product-category/accessories).

\*Recommended 25’ max run on both supply/return ducting.

## 5. Control Options

The Quest Dual Dehumidifier can be controlled by its on board dehumidistat or with an external control using its low voltage terminal block.

### 5.1 On board dehumidistat

\*Place switch into dehumidistat mode.

The humidity control is an adjustable switch that closes when the relative humidity of the air in which it is located rises to the dial set point. It opens when the RH drops 4 to 6% below the set point.

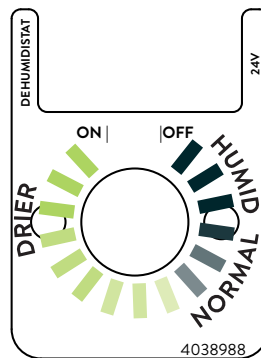

#### Approximate Humidity Levels Per Setting

“Dry”	20% to 30% Relative Humidity
“Normal”	50% Relative Humidity (Recommended)
“Humid”	80% to 90% Relative Humidity

The dehumidifier will run until the relative humidity (RH) is reduced to the humidity control dial setting.

### 5.2 External Control

\*Place switch to 24V mode.

The Quest Dual Dehumidifier is controlled using five terminals.

COM = 24volt AC power transformer neutral side (common with white)

FAN = Fan control

24V = transformer high side

DEHU = Dehumidification (fan and compressor) control

FLOAT = Normally closed, external float switch can be wired to turn off unit

Between the COM and the 24V is a 40VA transformer. This low voltage power source powers the relay coils which control the fan and compressor. This 24VAC transformer can also be used to power HVAC accessories external to the dehumidifier.

- To turn on the dehumidifier make contact between 24V and DEHU terminals.
- To turn on the fan make contact between 24V and FAN terminals.
- To power a 24V HVAC accessory, connect the accessory to the COM terminal and the 24V terminal.

**NOTE: 18 ga wire needed between the Quest Dual dehumidifier and the external control**

Quest offers two external control options

#### 5.2A DEH 3000R

**NOTE: 22 ga wire needed for sensor**

4028531

QUEST DEH 3000R CONTROL WIRING DIAGRAM

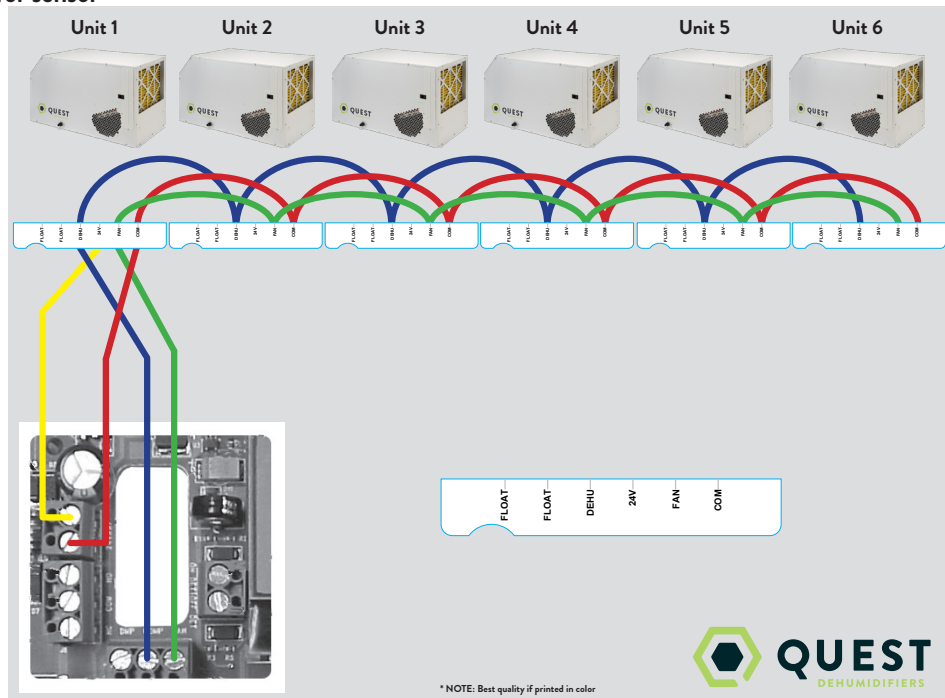
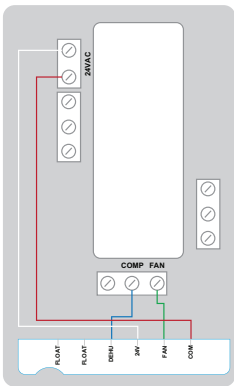

\* NOTE: Best quality if printed in color



Contact your dealer or call 1-877-420-1330 to order or go to [www.questclimate.com/product-category/accessories](http://www.questclimate.com/product-category/accessories).



## 5.2B Honeywell Remote Humidistat

4020175

HONEYWELL REMOTE HUMIDISTAT  
WIRING DIAGRAM

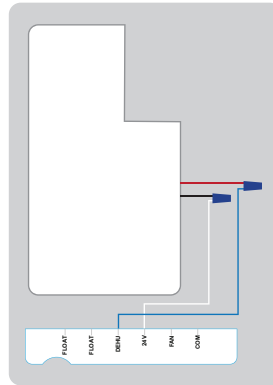

## 6. Maintenance

**⚠ WARNING! NOTE: Do not operate the unit without the filter or with a less effective filter. The heat exchange coils inside the unit could become clogged and require disassembly to clean. Filter non-compliance invalidates the product warranty.**

### 6.1 Standard Air Filter

The Quest Dual Dehumidifier ships with a standard MERV 11 efficient pleated fabric filter. This filter should be checked every six months. Operating the unit with a dirty filter will reduce dehumidifier capacity and efficiency and may cause the compressor to cycle off and on unnecessarily on the defrost control.

To access the air filter, remove the filter access panel from the end of the Quest Dual Dehumidifier. The filter should be readily visible and can be removed by pulling it straight out of the Quest Dual Dehumidifier.

We recommend changing the filter at least every 6 months. For agriculture we recommend changing the filter with every grow cycle.

### 6.2 Impeller Fan Oiling

The impeller fan motor is factory lubricated for many years of normal operation, and no further oiling is required.

## 7. Service

**⚠ WARNING! Servicing the Quest Dual with its high pressure refrigerant system and high voltage circuitry presents a health hazard which could result in death, serious bodily injury, and/or property damage. Only qualified service people should service this unit.**

### 7.1 Warranty

A warranty certificate has been enclosed with this unit; read it before any repair is initiated. If a warranty repair is required, call the factory first at 1-877-420-1330 for warranty claim authorization and technical assistance.

## 7.2 Technical Description

The Quest Dual Dehumidifier uses a refrigeration system similar to an air conditioner's to remove heat and moisture from incoming air, and add heat to the air that is discharged.

Hot, high-pressure refrigerant gas is routed from the compressor to the condenser coil. The refrigerant is cooled and condensed by giving up its heat to the air that is about to be discharged from the unit. The refrigerant liquid then passes through a filter/drier and capillary tubing which causes the refrigerant pressure and temperature to drop. It next enters the evaporator coil where it absorbs heat from the incoming air and evaporates. The evaporator operates in a flooded condition, which means that all the evaporator tubes contain liquid refrigerant during normal operation. A flooded evaporator should maintain nearly constant pressure and temperature across the entire coil, from inlet to outlet.

The mixture of gas and liquid refrigerant enter the accumulator after leaving the evaporator coil. The accumulator prevents any liquid refrigerant from reaching the compressor. The compressor evacuates the cool refrigerant gas from the accumulator and compresses it to a high pressure and temperature to repeat the process.

## 7.3 Troubleshooting

**Neither fan nor compressor running. Dehumidification is being called for. No fan call.**

1. Unit unplugged or no power to outlet.
2. Humidity control set too high.
3. Loose connection in internal or control wiring.
4. Defective Compressor relay.
5. Defective control transformer.

**Compressor is not running. Dehumidification is being called for. No fan call.**

1. Defective compressor run capacitor.
2. Loose connection in compressor circuit.
3. Defective compressor overload.
4. Defective compressor.
5. Defrost thermostat open.

**Compressor cycles on and off. Dehumidification is being called for. No fan call.**

1. Low ambient temperature and/or humidity causing unit to cycle through defrost mode.
2. Defective compressor overload.
3. Defective compressor.
4. Defrost thermostat defective.
5. Dirty air filter(s) or air flow restricted.

**Fan is not running. Dehumidification or fan is being called for.**

1. Loose connection in fan circuit.
2. Obstruction prevents fan impeller rotation.
3. Defective fan.
4. Defective fan relay.

**Low dehumidification capacity (evaporator is frosted continuously). Dehumidification is being called for**

1. Defrost thermostat loose or defective.
2. Low refrigerant charge
3. Dirty air filter(s) or air flow restricted.
4. Excessively restrictive ducting connected to unit.

**No ventilation. Ventilation is being called for.**

1. Loose connection in ventilation control circuit
2. Loose connection in damper power circuit.
3. Defective fresh air damper.

**Unit removes some water, but not as much as expected.**

1. Air temperature and/or humidity have dropped.
2. Humidity meter and or thermometer used are out of calibration.
3. Unit has entered defrost cycle.
4. Air filter dirty.
5. Defective defrost thermostat.
6. Low refrigerant charge.
7. Air leak such as loose cover or ducting leaks.
8. Defective compressor.
9. Restrictive ducting.
10. Optional Condensate Pump Safety Switch open.

**Unit Test to determine problem:**

1. Detach field control wiring connections from main unit.
2. Connect the 24V and FAN from the main unit together; only the impeller fan should run. Disconnect the wires.
3. Connect the 24V and DEHU from the main unit together; the compressor and impeller fan should run.
4. If these tests work, the main unit is working properly. You should check the control panel and field control wiring for problems next.
5. Remove the control panel from the mounting box and detach it from the field installed control wiring. Connect the DEHU, 24V, and FAN terminals from the control panel directly to the corresponding locations on the main unit. Leave the, FLOAT and COM terminals disconnected!
6. Turn on the fan switch; the impeller fan should run. Turn off the fan switch.
7. Turn on the humidity control; the compressor and impeller fan should run.
8. If these tests work, the problem is most likely in the field control wiring.

## 7.4 Refrigerant Charging

If the refrigerant charge is lost due to service or a leak, a new charge must be accurately weighed in. If any of the old charge is left in the system, it must be recovered before weighing in the new charge. Refer to the unit nameplate for the correct charge weight and refrigerant type.

## 7.5 Impeller Fan Replacement

The motorized impeller fan is a unitary assembly consisting of the motor and impeller fan. If defective, the complete assembly must be replaced.

1. Unplug the power cord.
2. Remove the cabinet access panel.
3. Remove the screw attaching the impeller fan support bracket to the base.
4. Disconnect the impeller fan leads inside the electric box.
5. Remove fan/bracket assembly by removing 3 screws from the bracket and inlet ring assembly.
6. Remove the defective impeller fan from the bracket and replace with it with the new impeller fan.
7. Reassemble the new impeller fan by reversing the above procedure. Note: There are two pins on the backside of the cabinet that must align with the two holes in the impeller fan support bracket.

## 7.6 Compressor/Capacitor Replacement

This compressor is equipped with a two terminal external overload and a run capacitor, but no start capacitor or relay (See Figure 4).

### 7.6A Checking Compressor Motor Circuits

Perform the following tests if the impeller fan runs but the compressor does not with the fan switch and ventilation timer OFF and the humidity control ON.

1. Unplug the unit; remove the cabinet side and the electrical connection cover on the compressor top.
2. Plug in the unit and turn the humidity control to ON. Check for volts from compressor terminal R to overload terminal 3 using an AC voltmeter. If correct voltage is present, go to step 3. If no voltage, there may be a loose connection in the compressor circuit. Test each component for continuity. See the appropriate section if a defect is suspected.
3. Unplug the unit, and then disconnect the red and yellow wires from compressor terminals R & S. Using an ohmmeter check continuity between the points listed below.
4. Compressor terminals C and S: No continuity indicates an open start winding. The compressor must be replaced. Normal start winding resistance is 3 to 7 ohms.
5. Compressor terminals C and R: No continuity indicates an open run winding. The compressor must be replaced. Normal run winding resistance is .5 to 2 ohms.
6. Compressor terminal C and overload terminal 1: No continuity indicates a defective overload lead.
7. Overload terminals 1 and 3: If there is no continuity, the overload may be tripped. Wait 10 minutes and try again. If there is still no continuity, it is defective and must be replaced.
8. Compressor terminal C and compressor case: Continuity indicates a grounded motor. The compressor must be replaced.
9. Disconnect the wires from the run capacitor. Set the ohmmeter to the Rx1 scale. The capacitor is shorted and must be replaced if continuity exists across its terminals. If there is no needle movement with the meter set on the Rx100000 scale, the capacitor is open and must be replaced.
10. Reconnect the wires to the compressor and capacitor. Plug in and turn on the unit. If the compressor fails to start, replace the run capacitor.
11. If the unit still does not start, adding a hard-start kit (relay & capacitor) will provide greater starting torque. If this doesn't work, the compressor has an internal mechanical defect and must be replaced.

### 7.6B Replacing a Burned Out Compressor

The refrigerant and oil mixture in a compressor is chemically very stable under normal operating conditions. However, when an electrical short occurs in the compressor motor, the resulting high temperature arc causes a portion of the refrigerant oil mixture to break down into carbonaceous sludge, a very corrosive acid, and water. These contaminants must be carefully removed otherwise even small residues will attack replacement compressor motors and cause failures.

The following procedure is effective only if the system is monitored after replacing the compressor to insure that the clean up was complete.

1. This procedure assumes that the previously listed compressor motor circuit tests revealed a shorted or open winding.
2. Remove and properly dispose of the system charge. **DO NOT** vent the refrigerant or allow it to contact your eyes or skin.
3. Remove the burned out compressor. Use rubber gloves if there is any possibility of contacting the oil or sludge.
4. To facilitate subsequent steps, determine the type of burn out that occurred. If the discharge line shows no evidence of sludge and the suction line is also clean or perhaps has some light carbon deposits, the burn out occurred while the compressor was not rotating. Contaminants are therefore largely confined to the compressor housing. A single installation of liquid and suction line filter/driers will probably clean up the system.

If sludge is evident in the discharge line, it will likely be found in the suction line. This indicates the compressor burned out while running. Sludge and acid have been pumped throughout the system. Several changes of the liquid and suction filter/driers will probably be necessary to cleanse the system.

5. Correct the system fault that caused the burn out. Consult the factory for advice.
6. Install the replacement compressor with a new capacitor and an oversized liquid line filter.  
In a running burn out, install an oversized suction line filter/drier between the accumulator and compressor. Thoroughly flush the accumulator with refrigerant to remove all trapped sludge and to prevent the oil hole from becoming plugged. A standing burn out does not require a suction line filter/drier.
7. Evacuate the system with a good vacuum pump and accurate vacuum gauge. Leave the pump on the system for at least an hour.
8. Operate the system for a short period of time, monitoring the suction pressure to determine that the suction filter is not becoming plugged. Replace the suction filter/drier if pressure drop occurs. If a severe running burn out has occurred, several filter/driers may have to be replaced to remove all of the acid and moisture.

**NOTE: NEVER use the compressor to evacuate the system or any part of it.**

### 7.6C Replacing a Compressor, Nonburn Out

Remove the refrigerant from the system. Replace the compressor and liquid line filter/drier. Charge the system to 50 PSIG and check for leaks. Remove the charge and weigh in the refrigerant quantity listed on the nameplate. Operate the system to verify performance.

### 7.7 Remote Controls

The Quest Dual Dehumidifier is controlled by devices mounted on a panel that is remote from the unit. You may or may not have the devices listed below depending on the model of the remote control panel you purchased. If the Quest Dual Dehumidifier fails to operate as desired, always check the settings of the controls to insure that they are correct. Check that the controls are receiving 24VAC from the Quest Dual Dehumidifier. Check the connections between the Quest Dual Dehumidifier, the control panel, and the field control wiring.

### 7.7A Humidity Control

The humidity control is an adjustable switch that closes when the relative humidity of the air in which it is located rises to the dial set point. It opens when the RH drops 4 to 6% below the set point. If the Quest Dual Dehumidifier does not run, try turning the humidity control clockwise until it reaches the stop and the knob pointer points at “Max Dry” (see back of control panel cover). If it still does not run, remove the stop screw from the panel and turn the knob farther. If it then runs, the humidity control is out of calibration or the RH is below 40%.

The Quest Dual Dehumidifier is equipped with an automatic defrost mechanism. If the Quest Dual Dehumidifier operates in conditions that develop frost on the evaporator, it will sense the frost build-up and automatically defrost the evaporator. The Quest Dual Dehumidifier may not appear to be operating correctly during the defrost sequence, but once the defrost sequence is completed, the Quest Dual Dehumidifier will resume dehumidifying.

### 7.8 Defrost Thermostat

The defrost thermostat is attached to the refrigerant suction tube between the accumulator and the compressor. It will automatically shut the compressor off if the low side refrigerant temperature drops due to excessive frost formation on the evaporator coil. The impeller fan will continue to run, causing air to flow through the evaporator coil and melt the ice. When the ice has melted, the evaporator temperature will rise and the thermostat will restart the compressor.

### 7.9 Electric Ventilation Damper

The electric ventilation damper is controlled by the ventilation timer. The damper will open when the ventilation timer is activated to allow fresh air into the structure through the 6” diameter fresh air inlet duct. The electric ventilation damper will remain closed when the ventilation timer is not activated to prevent over-ventilating the structure when the unit is dehumidifying or recirculating the indoor air.

The electric ventilation timer operates on 24 VAC from the control circuit. **DO NOT** connect high voltage to the damper motor or damage to the motor may result. **DO NOT** force the blade of the damper by hand or damage to the damper motor may result.

The damper opens in one direction only. The damper rotates very slowly, allow sufficient time for the damper to cycle. The damper will take approximately 1 minute to cycle from closed to open or from open to closed.

If the electric ventilation damper fails to operate:

1. Check that the wiring is correct and that voltage is present at the damper motor.
2. Check for any obstruction inside the damper. If the electric ventilation damper fails to operate after performing these checks, it must be replaced.

### 7.10 Condensate Pump Kit

An optional condensate pump kit is available from the factory for use with the Quest Dual Dehumidifier. Condensate is automatically pumped to a remote location when the water level in the pump's reservoir rises to close the float switch.

The pump also contains a safety float switch. The white leads from this switch extend from beneath the pump cover. This switch should be installed in series with the field wire that connects the 24V from the Quest Dual Dehumidifier to the control panel.

If the pump fails, this switch opens the compressor control circuit and stops water production before the reservoir overflows. The Quest Dual Dehumidifier will continue to ventilate or circulate air as normal, but will not dehumidify until this switch closes.

Wiring Diagram of the Quest Dual Dehumidifier

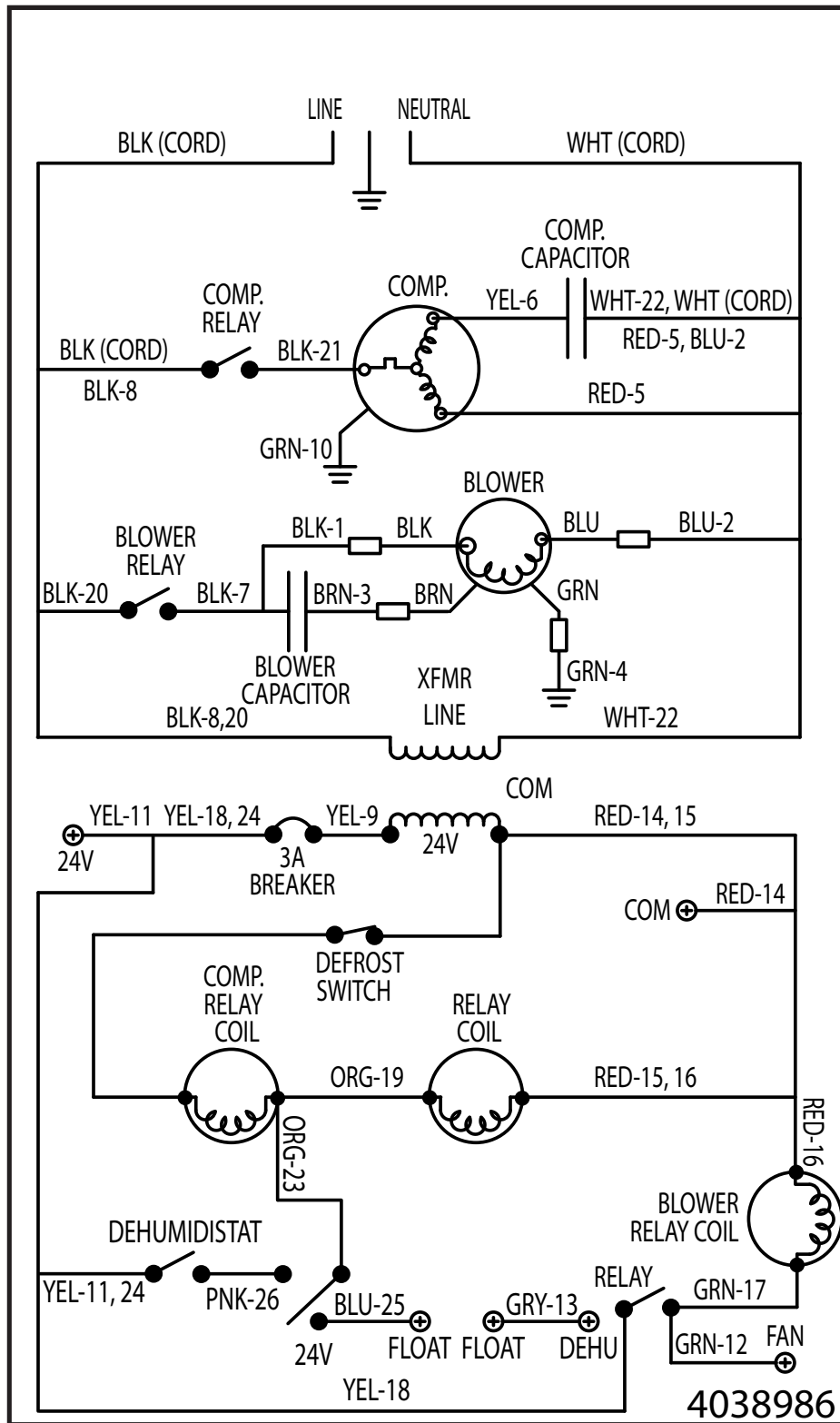

**Service Parts List**

Item	Part No	Qty	Description	Item	Part No	Qty	Description
1	4021475	1	Air Filter 16x20x2" MERV-11	8	4039361	1	(165 Dual) Impeller
2	4026221	4	Foot, Leveling, 5/16-18 x 2.25	8	4036492	1	(225 Dual) Impeller
3	4031085-02	1	Condenser Coil	9	4035949-09	1	(165 Dual) Capacitor, Run, 25 MFD, 440V
4	4031086-05	1	E-Coat Evaporator Coil	9	4035949-10	1	(225 Dual) Capacitor, Run, 45 MFD, 440V
5	4029510	1	Filter/Drier	10	4037221-04	1	(165 Dual) Capacitor, Fan, 4 MFD, 440V, Dry
6	4025741	1	(165 Dual) Thermostat, Defrost Control	10	4037221-05	1	(225 Dual) Capacitor, Fan, 5 MFD, 440V, Dry
6	4032229	1	(225 Dual) Thermostat, Defrost Control	11	4020924	1	Relay, SPDT, 24V, 15A
7	4039982	1	(165 Dual) Compressor	12	4022484	1	Relay, SPST, 24V, 30A
7	4039984	1	(225 Dual) Compressor	13	4036398	1	XFMR, 240V, 50/60Hz, 24V, 40VA
	4039986	1	(165 Dual) Compressor Overload NOT SHOWN	14	4036559	1	Circuit Breaker NOT SHOWN
	4039988	1	(225 Dual) Compressor Overload NOT SHOWN				

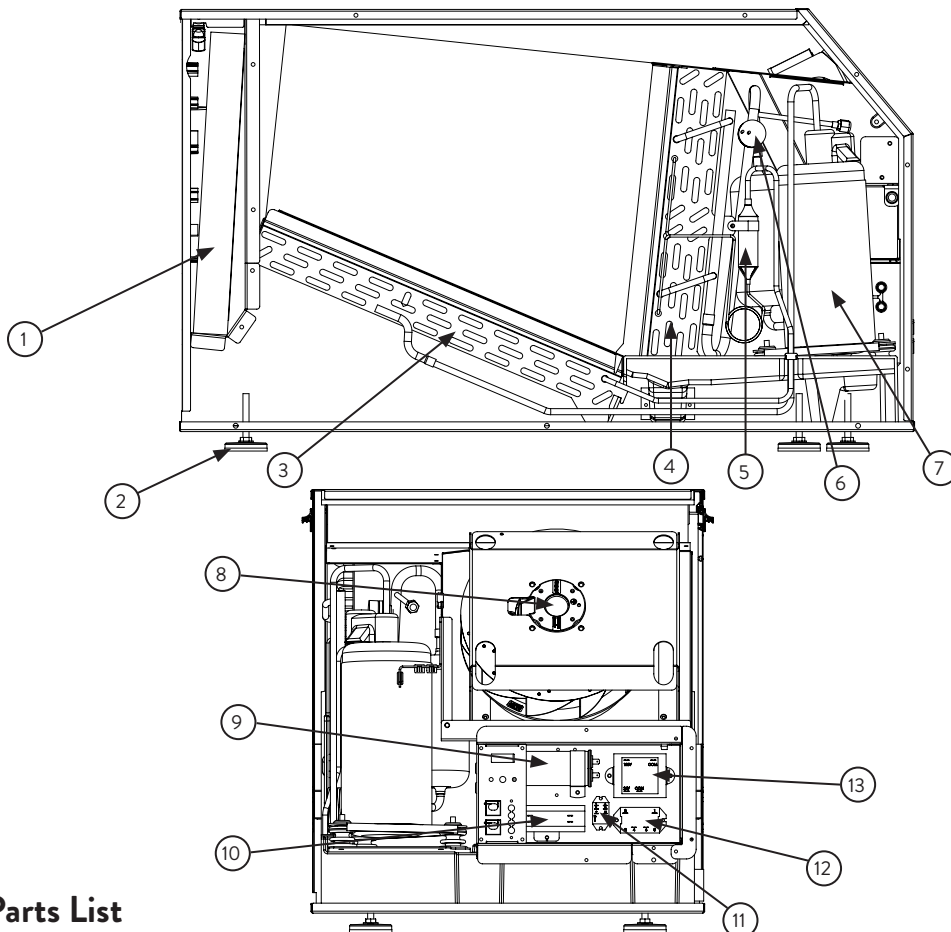

**Optional Parts List**

PART NO.	QTY.	DESCRIPTION	PART NO.	QTY.	DESCRIPTION
4020175	1	Controller, Humidity	4028531	1	DEH 3000R Control, Remote
4022220	1	Pump Kit (110-120V)	4036668	2	Bracket, Hanging (2 Required)
4028607	1	Supply Duct Kit			
4028610	1	Return Duct Kit			



## Quest Dual Dehumidifier Limited Warranty

### WARRANTOR:

Therma-Stor LLC  
4201 Lien Rd  
Madison, WI 53704  
Telephone: 1-800-533-7533

**WHO IS COVERED:** This warranty extends only to the original end-user of the Quest Dual Dehumidifier dehumidifier, and may not be assigned or transferred.

**FIRST YEAR WARRANTY:** Therma-Stor LLC warrants that, for one (1) year the Quest Dual Dehumidifier dehumidifier will operate free from any defects in materials and workmanship, or Therma-Stor LLC will, at its option, repair or replace the defective part(s), free of any charge.

**SECOND THROUGH FIFTH YEAR WARRANTY:** Therma-Stor LLC further warrants that for a period of five (5) years, the condenser, evaporator, and compressor of the Quest Dual Dehumidifier dehumidifier will operate free of any defects in material or workmanship, or Therma-Stor LLC, at its option, will repair or replace the defective part(s), provided that all labor and transportation charges for the part(s) shall be borne by the end-user.

**END-USER RESPONSIBILITIES:** Warranty service must be performed by a Servicer authorized by Therma-Stor LLC. If the end-user is unable to locate or obtain warranty service from an authorized Servicer, he should call Therma-Stor LLC at the above number and ask for the Therma-Stor LLC Service Department, which will then arrange for covered warranty service. Warranty service will be performed during normal working hours.

The End-user must present proof of purchase (lease) upon request, by use of the warranty card or other reasonable and reliable means. The end-user is responsible for normal care. This warranty does not cover any defect, malfunction, etc. resulting from misuse, abuse, lack of normal care, corrosion, freezing, tampering, modification, unauthorized or improper repair or installation, accident, acts of nature or any other cause beyond Therma-Stor LLC's reasonable control.

**LIMITATIONS AND EXCLUSIONS:** If any Quest Dual Dehumidifier Dehumidifier part is repaired or replaced, the new part shall be warranted for only the remainder of the original warranty period applicable thereto (but all warranty periods will be extended by the period of time, if any, that the Quest Dual Dehumidifier Dehumidifier is out of service while awaiting covered warranty service).

UPON THE EXPIRATION OF THE WRITTEN WARRANTY APPLICABLE TO THE Quest Dual Dehumidifier DEHUMIDIFIER OR ANY PART THEREOF, ALL OTHER WARRANTIES IMPLIED BY LAW, INCLUDING MERCHANTABILITY AND FITNESS FOR A PARTICULAR PURPOSE, SHALL ALSO EXPIRE. ALL WARRANTIES MADE BY THERMA-STOR LLC ARE SET FORTH HEREIN, AND NO CLAIM MAY BE MADE AGAINST THERMA-STOR LLC BASED ON ANY ORAL WARRANTY. IN NO EVENT SHALL THERMA-STOR LLC, IN CONNECTION WITH THE SALE, INSTALLATION, USE, REPAIR OR REPLACEMENT OF ANY Quest Dual Dehumidifier DEHUMIDIFIER OR PART THEREOF BE LIABLE UNDER ANY LEGAL THEORY FOR ANY SPECIAL, INDIRECT OR CONSEQUENTIAL DAMAGES INCLUDING WITHOUT LIMITATION WATER DAMAGE (THE END-USER SHOULD TAKE PRECAUTIONS AGAINST SAME), LOST PROFITS, DELAY, OR LOSS OF USE OR DAMAGE TO ANY REAL OR PERSONAL PROPERTY.

Some states do not allow limitations on how long an implied warranty lasts, and some do not allow the exclusion or limitation of incidental or consequential damages, so one or both of these limitation may not apply to you.

**LEGAL RIGHTS:** This warranty gives you specific legal rights, and you may also have other rights which vary from state to state.