



SPECIFICATIONS

KBP1000

DESCRIPTION

1000 CFM Combination Air Scrubber | Negative Air Machine

AIR PURIFICATION

| | |
|-----------------------|--------------------------------|
| ULPA/HEPA Filter | 99.97% @ > .3 Microns |
| UVC Light Wave Length | UVC 30 Watts / Max 85 Watts x2 |

FAN DATA

| | |
|--------------------------------|---|
| Fan Type (Centrifugal) | Direct Drive |
| Air Flow (CFM) | 1000/875/750 - 3 Speed / Quad Directional |
| Top Discharge Stainless Flange | 10 In. / Optional 12 In. |
| Optional CK-12S-SS Ceiling Kit | Optional 12" Dia. Ceiling Kit |

ELECTRICAL DATA

| | |
|-----------------------------------|----------------------|
| Power Supply | 115 V / Single Phase |
| Current Consumption | 5.94 Amps |
| Power Consumption | 0.68 kW |
| Maximum Circuit Breaker | 20 Amps |
| Recommended Breaker Size | 15 |
| Minimum Circuit Ampacity | 8.17 Amps |
| Min/Max Voltage | 105 - 125 |
| Power Cord Gauge / Length in Feet | 14 AWG / 6' |
| Plug Configuration | NEMA 5 - 15 |

DIMENSIONAL DATA

| | |
|--|----------------------|
| Width x Length x Height (inches) | 16.5" x 22.25" x 38" |
| Weight (lbs) | 90 |
| Shipping Weight (lbs) | 125 |
| Ceiling Kit - CK - 12SS (lbs) | 12 |
| Total Shipping Weight w/ Ceiling Kit (lbs) | 137 |

SAFETY DEVICE DATA

| | |
|--------------------|--------------------|
| Fan Motor Overload | Automatic Internal |
| Automatic Restart | Yes |

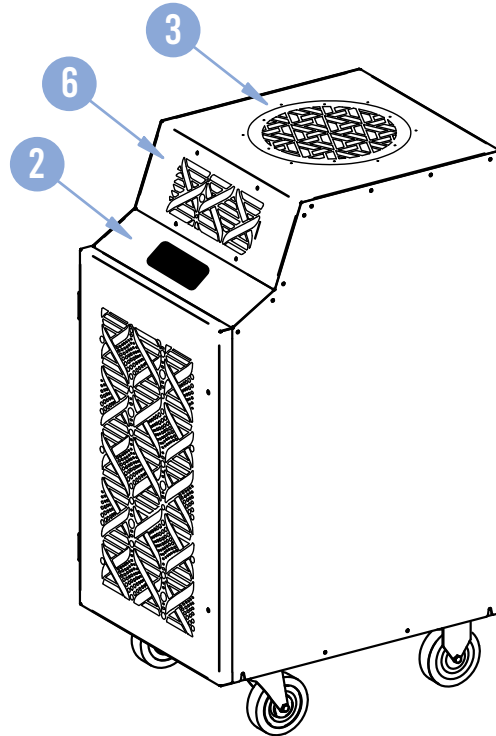
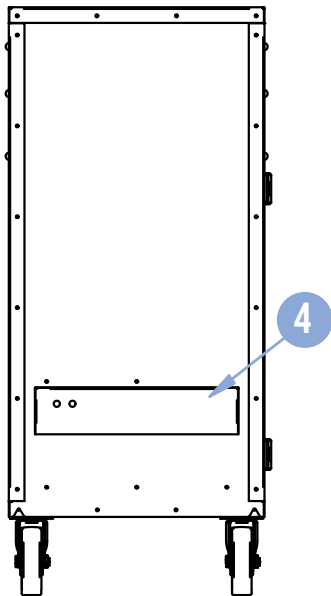
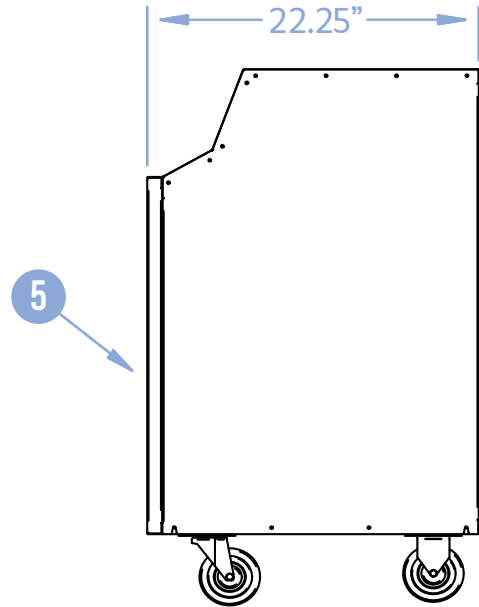
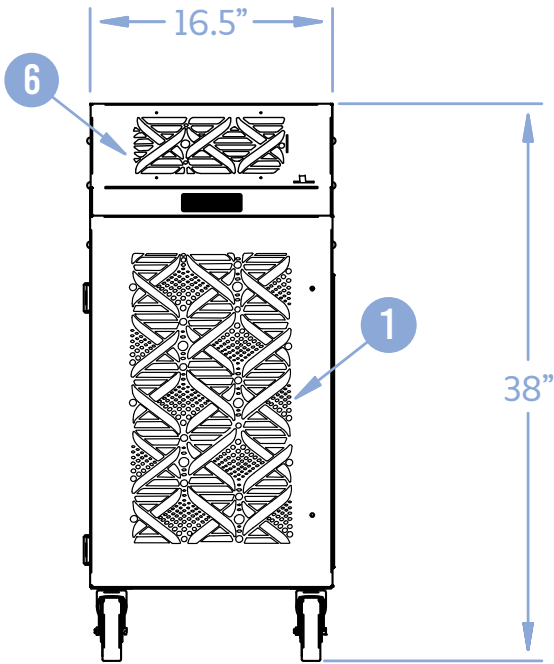

KBP1000

LEGEND

- 1. Room Air Return
- 2. Control Panel (Touch Pad)
- 3. Filtered Negative Air Supply
- 4. Cord Storage
- 5. Filter Access Door
- 6. Cleaned Room Air Supply



ETL LISTED CONFORMS TO ANSI/UL1995
CERTIFIED TO CAN/CSA 22.2 NO 235