



Owner's Manual

HEPA 2000 Air Scrubber

Model 123668

LEGEND BRANDS, INC.

15180 Josh Wilson Road, Burlington, WA 98233

Phone: 800-932-3030 Fax: 360-757-7950 LegendBrandsRestoration.com

The HEPA 2000 is a portable filtration system that draws air in from the surrounding environment and passes it through an advanced filtration system. The unit removes airborne particles such as dust, mold spores, pollen, pet dander and miscellaneous debris. Suitable for use—in homes, light industrial settings, schools, hospitality venues and healthcare environments—wherever portable, efficient HEPA filtration is needed.

READ AND UNDERSTAND BEFORE OPERATING

⚠ WARNING

ELECTRIC SHOCK HAZARD

The unit must be electrically grounded. Use only on GFCI protected receptacles.

Connect to a properly grounded outlet only. Do not cut off the grounding prong. Do not use with an adapter.

Do not use with extension cords.

Do not use with damaged cord or plug. If appliance is not working as it should, has been dropped, damaged, left outdoors, or exposed to water, return it to an authorized service center for repair.

Unplug cord from outlet when not in use or when servicing machine.

⚠ WARNING

ELECTRIC SHOCK HAZARD

Keep motor and electrical parts dry.

Do not use outdoors. This machine is for indoor use only.

Do not handle plug or machine with wet hands.

Do not operate machine in standing water.



WARNING: This product may expose you to chemicals, including lead and phthalates, known to the State of California to cause cancer, birth defects, or other reproductive harm. For more information, go to P65Warnings.ca.gov



WARNING: Because federal, provincial and local laws and regulations have varying requirements for the application, testing and general use of equipment on asbestos abatement projects, Legend Brands, Inc., cannot warrant the use of any product we manufacture for asbestos abatement. Contractors performing abatement work should evaluate tools, equipment and procedures in light of their local regulatory requirements, and comply with those requirements.

NOTICE

Use only as described in this manual.

Do not pull or carry by cord, close a door or window on cord, or pull cord around sharp edges or corners. Do not roll appliance over cord. Keep cord away from heated surfaces.

To unplug, grasp the plug, not the cord. Do not pull cord to unplug.

Do not put any object into openings. Do not use with any opening blocked.

Do not use machine if not in proper operating condition.

Do not modify machine from its original design.

BEFORE YOU BEGIN

Warranty registration

Visit Warranty.LegendBrandsRestoration.com to register your purchase. Registration allows us to better assist you with using, maintaining, and servicing your equipment, as well as to contact you in case we have important safety information concerning this product. If you determine service is required, have your equipment model, serial number and original proof of purchase available and call your distributor for assistance with obtaining a return material authorization (RMA).

CONTROLS AND OPERATING INSTRUCTIONS

Variable Speed Control knob

Increase the fan speed by turning the knob (Fig. 1) clockwise. Fan speed can be adjusted between 500 and 2000 CFM.

Change Light

The change light (Fig. 1) illuminates when the HEPA filter needs to be changed.

Setup

1. Place the unit in the desired location. Lock the casters to secure the unit in place.

2. If desired, attach ducting to the Filtered Air Outlet (Fig. 1).

3. Plug in to a grounded GFCI-protected 115-volt outlet. Switch the unit on by turning variable speed control clockwise (Fig. 1). Rotate knob to selected desired air movement.

Note: To maintain the optimal air change rate, consult the IICRC S520 standards, 10.3.1.

Ducting options

The HEPA 2000 has a ductable 12 in. outlet, suitable for use with rigid and layflat ducting.

Negative Pressure Setup

The HEPA 2000 can be configured to set up a negative pressure containment area. Install the unit outside the containment area to draw air out. Only professionals with the appropriate training should set up negative pressure containment areas.

MAINTENANCE

BEFORE EACH USE

Inspect the electrical cord for damage. Look for fraying, cuts, or other damage. Do not use the unit if damaged. Contact your local distributor for a replacement cord.

Filter Change Light

The Change Filter Light illuminates when you need to change the HEPA filter. See Changing the HEPA filter (Fig. 2).

Fig 1: Changing the Prefilter

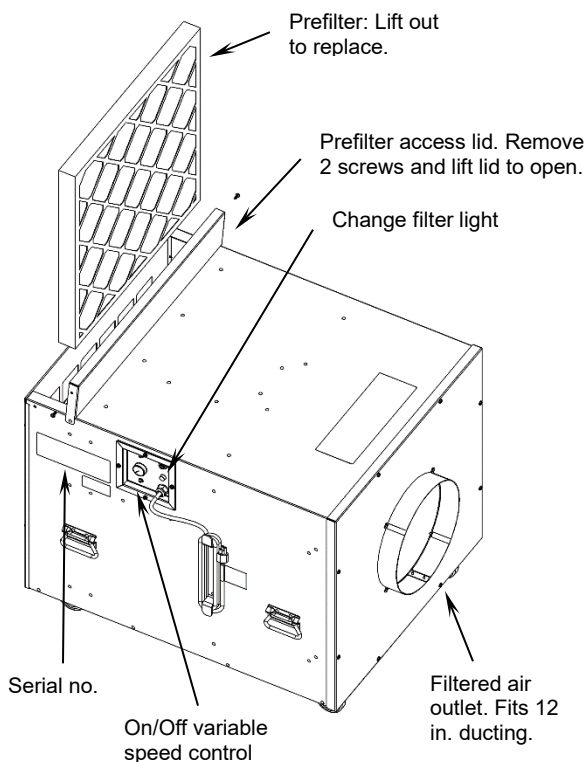

When using the HEPA 2000 for water damage restoration:

Inspect prefilter. Look for accumulated dust and dirt that could restrict airflow through the filter into the unit. If any is visible, change out the prefilter.

When using the HEPA 2000 for remediation:

After every job: Replace both the filters to prevent cross-contamination. Clean the unit thoroughly (vacuum and damp wipe per IICRC S520, 10.11) before removing it from the containment area to avoid cross-contamination. Let the unit dry before installing clean filters.

About the filters

The HEPA 2000 uses two types of disposable filters: prefilters and a HEPA filter. The prefilter section can be fitted with one or two filters. These prefilters are designed to capture larger airborne particles and to control odors, depending on the filter selected. The HEPA section is fitted with a filter designed to capture 99.97% of smaller particles down to 0.3 microns.

Filters should be replaced whenever they show visible accumulation of dust. For environments with a high volume of aerosolized particles, we recommend the use of two prefilters to extend the life of the HEPA filter.

Always replace the HEPA filter promptly when the Filter Change Light illuminates. Do not attempt to vacuum and reuse the HEPA filter.

NOTICE: When using the HEPA 2000 on remediation projects, the filters should be changed and properly disposed of after every job.

Replacement filters are available from your Dri-Eaz distributor.

CHANGING FILTERS

NOTICE: Always replace the HEPA filter when the Change Filter Light comes on.

Fig 2: Changing the HEPA filter

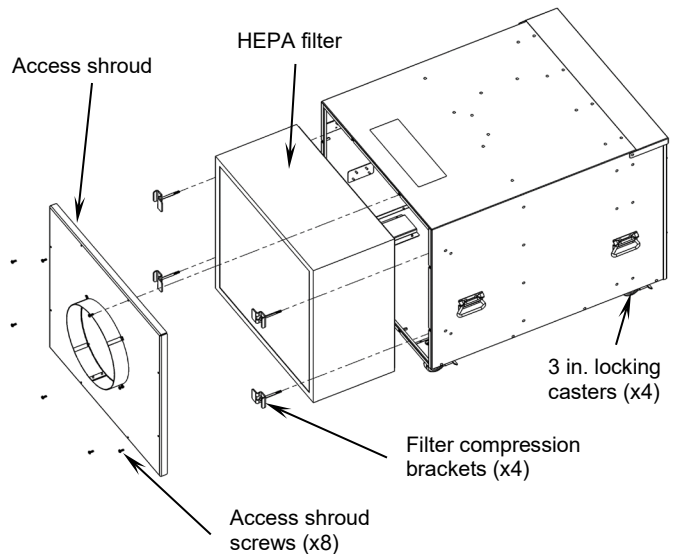

Changing the Prefilter (Fig. 1)

The Prefilter should be changed whenever it shows signs of accumulating debris or after use in an environment where potentially dangerous contaminants were present.

1. Remove the two prefilter compartment lid screws using a 5/16" hex driver or flat head screwdriver and open the lid.
2. Pull the filter up out of the unit until fully removed.
3. Insert the new filter from the top, in the innermost slot, ensuring that the air flow indicator arrow on the filter is pointing toward the inside of the unit.
4. Close the prefilter access lid. The unit is now ready for use.

Changing the HEPA Filter (Fig. 2)

NOTICE: Always replace the HEPA filter when the Change Filter Indicator Light comes on. In addition, the HEPA filter element should also be changed after every use in an environment where potentially dangerous contaminants were present.

1. Remove 8 screws from the access shroud and remove shroud. Retain the screws for reinstallation.
2. Remove the four filter compression brackets holding in the HEPA filter.
3. Pull the HEPA filter straight out of the unit. The sealing gasket on the opposite side of the filter may cause the filter to "stick" to the interior bulkhead wall. If necessary, turn the unit on briefly to push the filter out. Once the filter is loosened, turn the unit off and unplug the unit from power before removing the filter fully from the unit.
4. Insert the new HEPA filter with the sealing gasket facing the interior bulkhead wall, ensuring that the air flow indicator arrow on the filter is pointing away from the inside of the unit.
5. Replace the filter compression brackets, hand-tightening until a seal is achieved on the gasket.
6. Reinstall the access shroud using the 8 screws. The unit is now ready for use.

TRANSPORTATION AND STORAGE

NOTICE: Handle the unit carefully. Do not drop, throw, or place the unit where it could fall. Rough

treatment can damage this equipment and may create a hazardous condition or void warranty.

1. Do not expose the control panel to moisture, snow or rain when storing or transporting.
2. Store and transport securely to avoid any damage.

ADDITIONAL RESOURCES

- Visit the Legend Brands Restoration website at LegendBrandsRestoration.com
- *Dri-Eaz Guide to Air Scrubbing*. Free PDF download at LegendBrandsRestoration.com
- Institute of Inspection, Cleaning and Restoration Certification (IICRC), 360-693-5675. See especially the *S520: The Standard and Reference Guide for Professional Mold Remediation*.
- Restoration Sciences Academy. Visit RestorationSciencesAcademy.com or call 800-932-3030.
- NIOSH help line: 800-35-NIOSH. Provides respirator and respirator filter information.

FOR SERVICE CALL YOUR LOCAL DISTRIBUTOR or the Legend Brands Service Department at 800-932-3030.

SPECIFICATIONS

Model	HEPA 2000
Weight	124 lbs. 56.25 kg
Air movement	500–2000 CFM 850-3398 CMH
Static pressure	2.68 in. 6.81 cm H ₂ O
Dimensions (H × D × W)	28.37 × 29.17 × 35.63 in. 72.06 × 74.09 × 95.50 cm
Amps	7.7 A
Voltage	115 V
Frequency	60 Hz
Power cord	25 ft. 7.6 m
Construction	Marine grade aluminum sheet metal housing
Prefilter	24 x 24 x 2 in. MERV11 pleated HVAC
HEPA filter	24 x 24 x 12 in. H13 (99.97%) HEPA Filter, galvanized frame, fiberglass/paper media, aluminum foil separator
Safety	ETL listed to UL 507 and CSA C22.2 No. 113
<i>Specifications are subject to change without notice. Some values may be approximate.</i>	

HEPA 2000 REPLACEMENT FILTERS

FILTER DESCRIPTIONS

Pleated Synthetic Media Prefilter (Reorder #122781, case of 12/ea). Heavy-duty synthetic fiber MERV-11 HVAC pleated filter. Efficient, durable and moisture resistant; extends the life of the HEPA filter.

HEPA filter (Reorder #121754, 1 ea.). The HEPA filter has an efficiency rating of 99.97% against 0.3 micron oily aerosol particles.