

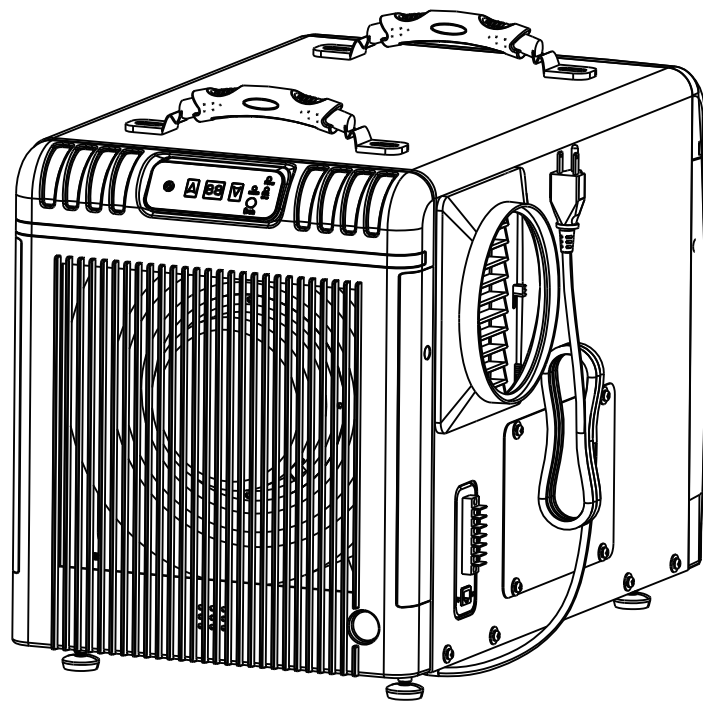

WatchDog 900C

Installation and Operations Manual



Seaira Global, LLC

14021 NC Hwy 50 Surf City, NC 28445

Phone:(910) 660-0962

Table of Contents

Warranty Registration	2
Safety Notes	2
Identification	3
Electrical Supply	3
Principle of Operation	3
Installation	3
Key Functions	4
Indicator Lights	5
Remote Control	6
Operating Instructions	6
Diagram	7
Maintenance	8
Dehumidifier Storage	9
Ducted Applications	9
Troubleshooting	11
Spare Parts	12
Warranty Information	13

Warranty Registration

Congratulations on purchasing a new Watchdog Dehumidifier. Your new dehumidifier comes with an extensive warranty plan. To register, simply fill out and return the warranty form provided in your dehumidifier box.

Be sure to note your dehumidifier serial number as you will need it for registration.

Safety Notes

- The Watchdog Series Dehumidifier must always be connected using a grounded electrical connection (as required for all electrical appliances). If non-grounded wiring is used, all liability reverts to owner and the warranty is voided.
- Watchdog Dehumidifiers should only be maintained and repaired by a qualified technician.
- Watchdog Dehumidifiers are only intended for operation when oriented with the unit sitting on its feet and level. Operating the unit in any other orientation could allow water to flood electrical components.
- Always unplug the dehumidifier before moving it to another location.
- If there is a chance that water flooded the dehumidifier, it should be opened and allowed to dry thoroughly before reconnecting to electrical power and restarting.
- To ensure proper operation, neither the inlet nor discharge should be positioned against a wall. The inlet requires a minimum of 12" clearance and the discharge requires a minimum of 36" clearance.
- The best option for proper diffusion of air throughout the room is to have the discharge blowing away from a wall and the inlet pulling air in parallel to a wall.
- Do not insert your fingers or any objects into the inlet or discharge.
- All work on the dehumidifier should be done with the unit "off" and unplugged.
- Do not use water to clean the exterior. To clean unit, unplug from power, then use a damp cloth to wipe the exterior.
- Do not stand on machine or use it as a device to hang clothes.

Identification

For future reference, write down the model, serial number, and date of purchase for your dehumidifier. This is extremely helpful if you need to seek assistance in the future. The data label on the side of your unit has the key characteristics of your specific unit.

Model Number: Seaira Watchdog 900C

Serial Number:_____ **Date of Purchase:**_____

For additional questions concerning your dehumidifier, the following options are available:

- Contact your installing contractor
- Call Seaira Global @ 910-660-0962

Electrical Supply

Power Supply: 115 V, 60 Hz AC, Single Phase

Outlet Requirement: 3-Prong, GFI

Circuit Protector: 15 Amp

WARNING: 120 Volts AC may cause serious injury from electric shock.

To reduce risk of injury:

1. Disconnect electrical power before servicing
2. Only plug unit into grounded electrical circuit
3. Do not use an extension cord
4. Do not use a plug adapter

Principle of Operation

The Watchdog Series Dehumidifiers utilizes its integral humidistat to monitor the conditioned space. When the relative humidity goes above the selected set point, the dehumidifier will energize. Air is drawn across an evaporator coil, which is cooler than the dew point of air. This means moisture will condense out of the air. The air is then reheated through the condenser coil and distributed back into the room.

Installation

The area to be controlled should be sealed with a vapor barrier. If unit is installed in a crawlspace, all vents should be sealed.

WARNING: Do not install your dehumidifier in a corrosive environment. Some liquid vapor barriers dry via “solvent evaporation”. Always make sure that barrier is completely dry and area is thoroughly ventilated before installing dehumidifier.

Step #1: Place dehumidifier on a level surface.

Do not place unit directly on vapor barrier. For example , use blocks or pavers to create a level surface.

If the unit is handled in such a manner that the compressor did not remain in the upright position, you will need to place it on a level surface, then wait a minimum of 2 hours before turning “on”.

Step #2: Set Up Drain Line

The included drain line attaches to unit via a compression type fitting on the discharge end of the unit. To attach drain line, remove the compression nut and slide it over the end of the hose to be attached to unit. Slide compression nut side of hose over the insert on the compression fitting completely. Tighten compression nut.

Step #3: Plug unit into 15 amp grounded circuit.

Key Functions

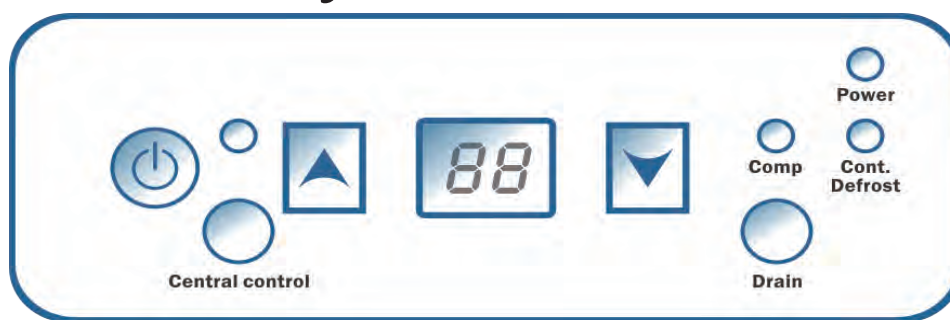

1. Power Key

- Use this button to turn the dehumidifier on and off. Press once to turn the machine on. You will hear one beep and the  light will illuminate red. Press the power button a second time and you will hear one beep as the machine shuts down. Note that there is a one minute fan delay on shutdown.

2. Arrow Buttons

- Use the up and down arrow buttons to set the desired humidity setpoint on the display screen.



The setpoint can be any number between 36-90%. Creating a setpoint means that when the indoor humidity is lower than the set point, the machine will stop automatically. Conversely, when the indoor humidity is higher than the set level, the unit will operate. NOTE: The humidity levels displayed are approximate only (+/- 5%).

3. Continuous Mode

- To switch into continuous mode, simply use the arrow keys to set the humidity below 36%. At this point the Cont. light should illuminate green on the display board to indicate you have successfully switched to continuous mode. The display screen will show “CO”.
- When set to continuous, the dehumidifier will run constantly, regardless of the humidity level until you turn the unit off or switch back to normal humidistat operation. If you would like to switch back to normal humidistat operation, simply move the setpoint above 36%.

4. Central Control

- This mode is not applicable on the WatchDog 900c.

5. Manual Drain Button

- For extended storage or movement of the machine, press the “Drain” button to remove water from the integral pump’s reservoir.

6. Pump Trouble Warning

- When the pump reservoir water level is too high, the high water sensor will activate to prevent overflow. When this occurs, the dehumidifier will stop the compressor automatically and the display will show “E4”. After a 1 minute delay, the fan motor will turn off and the machine will not operate until the problem is resolved. To reset the unit after an “E4” error, check the pump to verify it is functioning, then unplug the unit for two minutes.

Indicator Lights

1. Humidity Display Screen

- The display screen has two functions:

1. When the unit is powered on, it shows the indoor humidity.
2. While setting the desired humidity level, the screen will show the set humidity. After a brief delay, the display will revert to indoor humidity level.

2. Power Indicator Light

- This light indicates that the unit is properly powered on and ready to operate. Always make sure the unit is “off” prior to performing any service.

3. Continuous Mode/AutoDefrost Light

- When this light illuminates green, it indicates that the dehumidifier is set to continuous operation mode.
- When the light glows red, it means the unit is in auto defrost mode and clearing the evaporator coil of any ice buildup.

4. Compressor Light

- When the compressor light glows red, it indicates the compressor has been initiated but is currently warming up.
- Once the compressor light switches to green, it indicates the compressor is in working status.

5. Unit Indicator Light

- When the unit indicator light is red, it illustrates the dehumidifier is in unit mode.
- While in unit mode, the dehumidifier will use its built-in humidity sensor. If using a remote control, unit mode will allow you to remotely monitor the room conditions where the dehumidifier is located.

6. Remote Indicator Light

- When the remote indicator light is red, it illustrates the unit is remote mode.
- While in remote mode, the dehumidifier will use the sensor on the remote control unit. In this mode, the inlet and outlet of the dehumidifier can be ducted.

Remote Control Instructions

Watchdog Dehumidifiers can be controlled using an optional remote accessory. The Watchdog Remote Control connects to your Watchdog Series Dehumidifier via a 25' CAT 5 cable. The remote control contains an integrated sensor which gives you multiple options for remotely controlling your unit, in addition to monitoring the conditions surrounding the dehumidifier.

One application for the remote control is to install the dehumidifier in one room with the conditioned air ducted into a second room that contains the remote. For example, the dehumidifier could be installed in a laundry room and ducted into a living room. The remote would then be mounted in the living room so the remote sensor can control the humidity and provide easy controls for the user.

Another useful application for the remote control is if the dehumidifier is in area that's difficult to access on a regular basis. For instance, if your dehumidifier is installed in your crawl space, the remote could be mounted in your living space or garage. This provides you with an easy way to monitor the dehumidifier.

1. On/Off (Power) Button

Press the on/off button and the machine will start running (two beeps). Press the button again to turn the machine off.

2. Up Button ▲ / Down Button ▼

Use the Up and Down arrow buttons to adjust the humidity level.

3. Mode M

Use the Mode button to switch between dehumidification and a ducted application.

- The ☉ symbol on the display board indicates the sensor on the remote control is being utilized.
- The ▲ symbol on the display board indicates the sensor on the dehumidifier is being utilized

4. Temperature T

Press the temperature button to display the current temperature on the screen. Press the button again to turn off the display.

5. Continuous C

Press this button to switch the unit into continuous mode. **Cont.** will appear on the display to indicate continuous mode.

6. Drain Pump P

Use this button if the unit will not be in use for an extended period of time. Pressing the drain pump button will remove water from the pump reservoir, so the unit can be safely moved or stored.

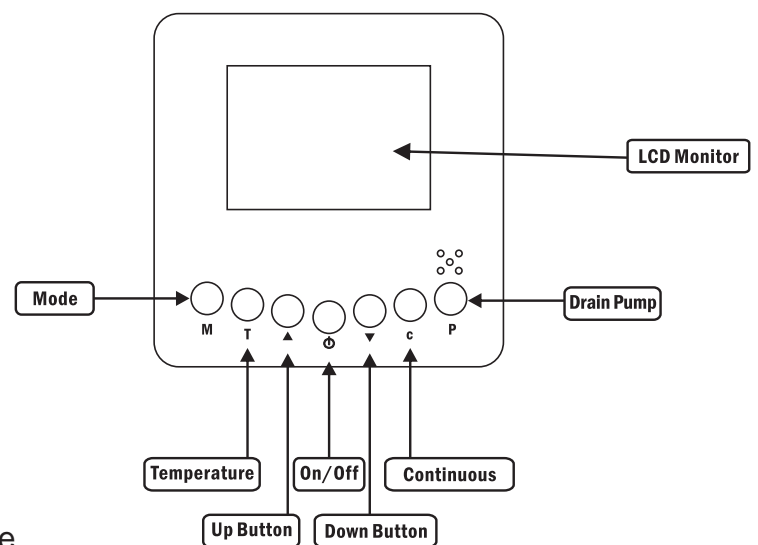

Operating Instructions

1. Start the machine

Press the power key to turn the machine on.

2. Adjust Settings

Use the up and down arrow keys to adjust your desired setpoint (typically 50-55%).

3. Stop the machine

Press the power key again and the machine will stop. Note the fan will continue to operate for 1 minute after the unit has shut off. NOTE: Do not disconnect power cord to force machine to stop. Always use power button.

4. Water Drainage

The Watchdog 900C has both automatic and manual draining. During normal operation, the Watchdog 900C will automatically drain as required. If you would like to store or move the machine, you may press the drain button to drain the water from the pump reservoir. The drain will operate for 15 seconds each time the button is pushed. It may be necessary to push the drain button more than once to completely empty the reservoir

Watchdog900C Diagram

Front View

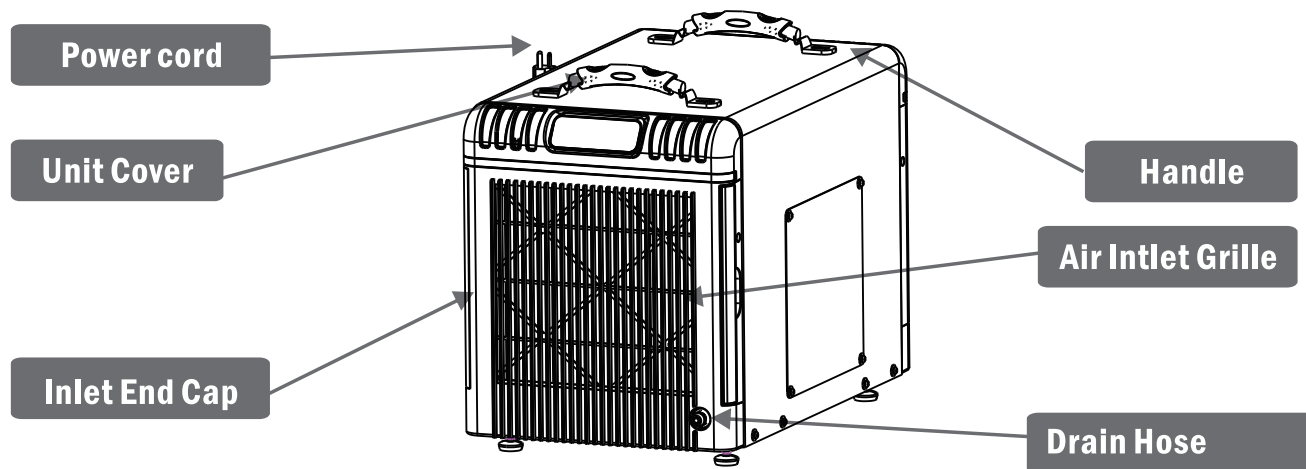

Back View

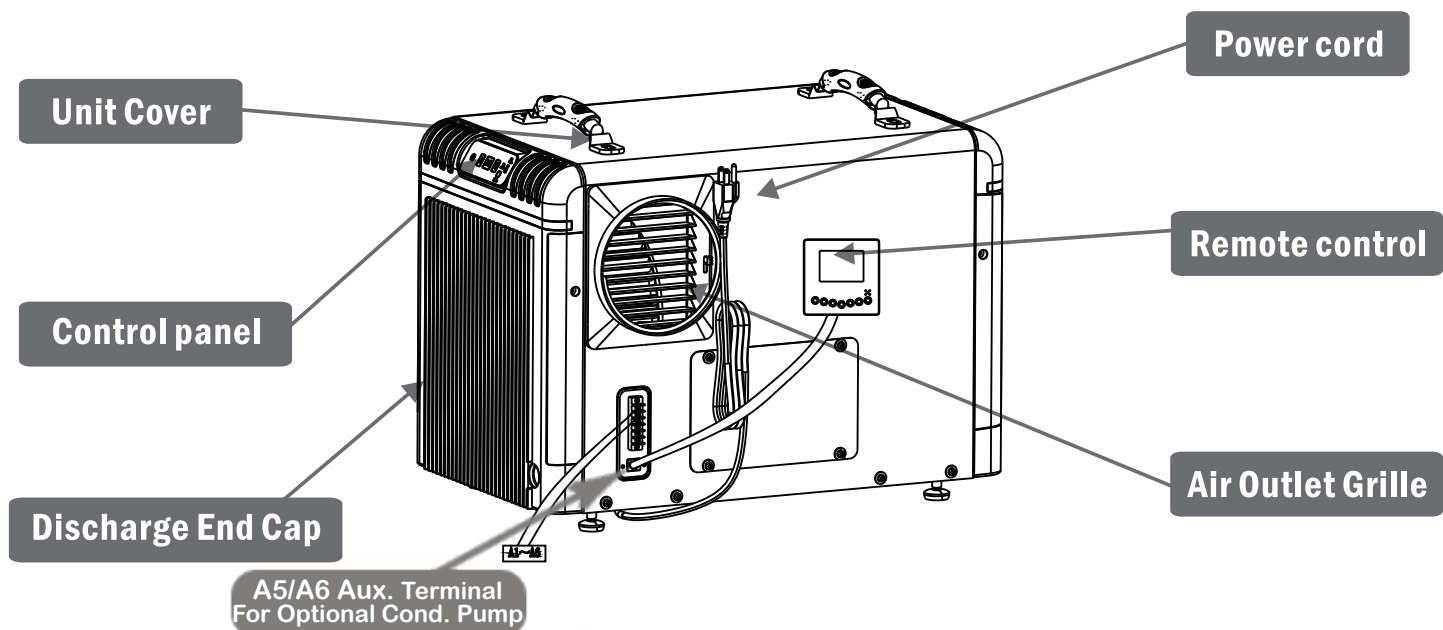

(not applicable for 900c model)

Maintenance

**For more detailed instructions visit www.SeairaGlobal.com

WARNING: Always unplug the unit before doing any maintenance.

Condensate Pump

Your Watchdog 900C is equipped with an integral condensate pump designed to pump water from your dehumidifier out to the desired drain. This pump requires routine maintenance that is not covered by your 1 year parts warranty. Only a defective pump will be repaired or replaced during the warranty period.

Preventative Maintenance

As with all pumps, preventative maintenance is necessary to prevent issues from dirt and slime that may accumulate in the drain system. This includes the drain pan, hose to the condensate pump, pump reservoir, pump head float assembly, and discharge tubing.

At least once per year, clean your pump system

☑ Cleaning the machine body

Use a soft damp cloth to clean exterior of unit. Do not use any soap or solvents.

☑ Cleaning the filter

1. Unplug the unit.
2. Slide out the filter.
3. Clean the filter mesh by vacuuming or washing with warm water (no soap or solvents).

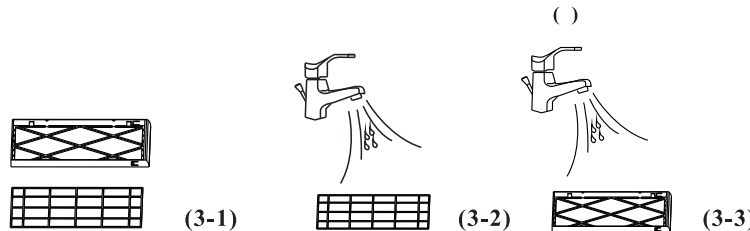
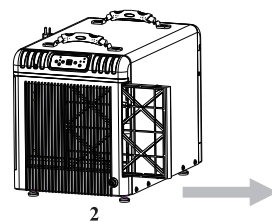

4. Be sure the filter is completely dry before reinserting.

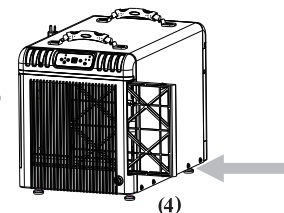

☑ Coil Maintenance

- Once per year, clean the coils with an approved coil cleaner. The coil cleaner should be a self-rinsing, foaming cleaner such as WEB® Coil Cleaner.

☑ Electrical maintenance

1. Unscrew the 4 screws on the access panel.
2. Carefully unplug control board wires.
3. Remove the control board.

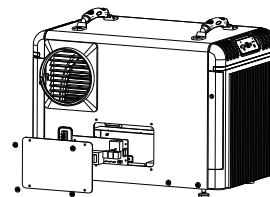

☑ Pump maintenance

1. Unscrew the 4 screws on the pump access panel.
2. Remove the screw on the pump.
3. Undo the 3 pump quick connects.
4. Insert a flathead screwdriver into the notch on the side of the pump to help you gently lift the pump off its reservoir (the reservoir remains attached to the unit).

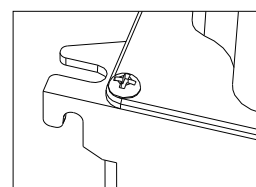
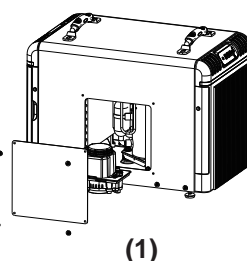

Cleaning/Disinfecting the Pump

Basic Cleaning (Complete about once a year, depending on environment)

1. Remove the end cap on the filter side of the unit. Press the drain button to drain the reservoir.
2. Disconnect power to the dehumidifier.
3. Mix a 16 oz solution of either (1 oz bleach + 15 oz water) OR (4 oz white vinegar + 12 oz water).
4. Pour solution into the drain tray at the base of the coils. If any cleaning solutions gets on coils, flush with water.
5. Allow solution to soak for 15 minutes.
6. Reconnect the dehumidifier to power.
7. Fill the reservoir and flush/cycle the pump at least two times.
8. If drain line is still filled with debris, repeat process. If still not cleaned, move on to Advanced Cleaning.
9. Reassemble unit, unless moving on to advanced cleaning.

Advanced Cleaning (Complete as needed)

1. Press the drain button to drain the water from the reservoir (A wet-dry vacuum or towels can be used to remove any remaining water).
2. Unplug the the dehumidifier and remove the cover so you have access to the pump.
3. Remove the pump head from the reservoir by unscrewing the screw. Wipe reservoir clean with a paper towel.
4. Mix a 16 oz solution of either (1 oz bleach + 15 oz water) OR (4 oz white vinegar+ 12 oz water).
5. Fill the pump reservoir with cleaning solution.
6. Reassemble pump, then use manual drain button to flush mixture through discharge tubing.
7. Pour same cleaning solution slowly into drain tray under evaporator coils and let it clean hose from pan to pump. This process can be stopped when the pump energizes one time. NOTE: If you get any of the cleaning solution on the coils, flush with water.
8. Pour sufficient clean water through drain pan to allow the pump to turn on twice.
9. Reassemble the unit and return it to operational status.

Dehumidifier Storage

If the unit will be stored for an extended period of time, complete the following steps:

1. Turn off the unit and allow to dry
2. Complete steps #1-3 in Advanced Cleaning (above) to wipe out reservoir
3. Wrap and secure the power cord
4. Cover filter mesh
5. Store in clean, dry space

Ducted Applications

Ducting the dehumidifier allows the unit to be in one room while conditioning an adjacent room. The inlet/return grille is designed for 12" flex ducting while the the supply grille is designed for 6" flex ducting.

Be sure to secure the ducting with tie wrap. Also, keep in mind, that the supply ducting can be screwed into an adapter if necessary.

Ducting Installation

- Maximum total length of duct run= 10'
- Maximum length if only ducting inlet or outlet= 6'
- To connect 12" return ducting, it may be helpful to:
 1. Remove inlet grille from end cap
 2. Connect duct to inlet grille
 3. Reconnect inlet grille to end cap

Note: The supply duct adapter is standard on all units.

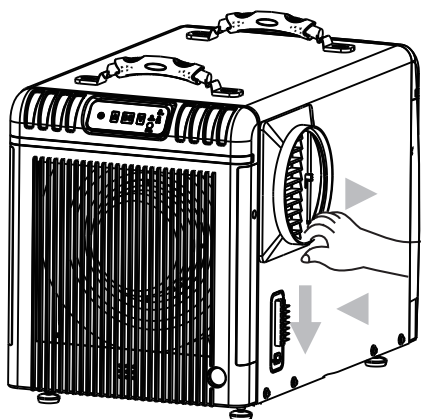

Removing Duct Adapter

If it is necessary to remove the adapter, place hand at bottom of the adapter and use your hands to lift out and down. This will remove the cover hooks from the machine.

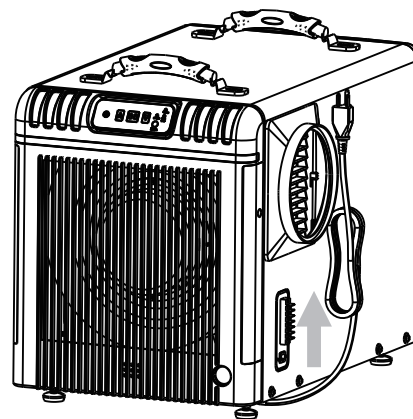

Installing Duct Adapter

To install adapter, line it up with holes on the side of unit and push up from base of adapter.

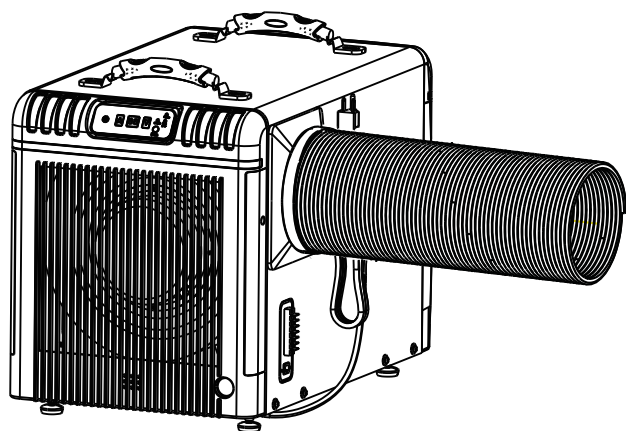

Flex Duct Installation

Rotate the flex duct counter-clockwise.

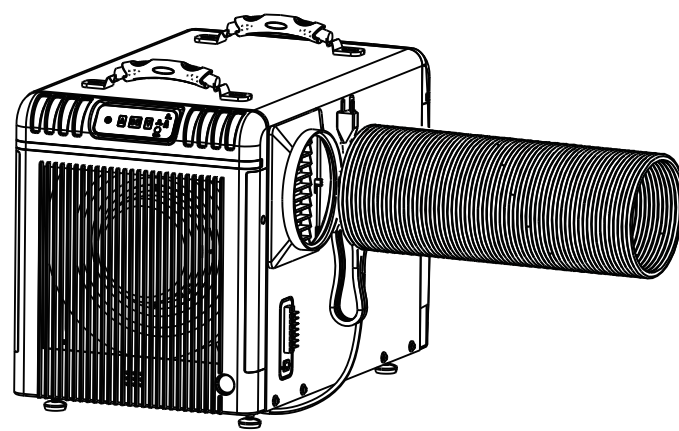

Flex Duct Removal

Rotate flex duct clockwise or remove wire tie.

Troubleshooting

Symptom	Cause	Solution
Machine Won't Run	Power Supply	Verify that there is power to the outlet and that the plug is properly installed in outlet
	Room Temperature Over 105°F (Display HI) or Below 33°F (Display LO)	The unit is outside the operating temperature range. Modify the room conditions so the temperature is between 33°-105°F and operation will commence.
Low Air Flow	Air Filter is Clogged	Clean the filter mesh according to instructions listed in manual.
	Air Inlet or Outlet is Blocked	Clear the blockage from inlet or outlet.
Loud Noise	Machine Is Not Level	Move the dehumidifier to flat, firm ground.
	Filter Mesh is	Clean the filter mesh according to instructions listed in manual.
Trouble Code E:1	E1=Humidity Sensor Issues	Check to ensure that wire is connected at both ends. If no issues are visible, the sensor may be faulty.
Trouble Code E: 4	Pump has failed	Verify that the pump is working. If so, unplug the unit for two minutes, then restart.
Trouble Code: HI or LO	Room Temperature Over 105°F or Below 33°F (Display LO)	The unit is outside the operating temperature range. Modify the room conditions so the temperature is between 33°-105°F and operation will commence. If room is not out of temperature range, replace faulty sensor.

Pump Alarm- Trouble Code E2/ E4

If a pump alarm is shown on the display, complete the following steps:

1. Reset the unit by disconnecting the power cord and then reconnecting it.

NOTE: UNIT WILL NOT FUNCTION UNTIL ERROR CODE HAS BEEN CLEARED.

2. Manually check to see if pump is operational by pressing the drain button. Check if the pump energizes and de-energizes properly. Additionally, check to see if any water purged from the system.

3. If you haven't cleaned the system recently, check the discharge line for an obstruction, then clean the balance of the pump system (see "Maintenance" on page 8 for details).

4. Replace the hoses and/or pump, if maintenance alone isn't sufficient.

Watchdog 900c Spare Parts

Remote Control	
W-100	Remote Control Assembly (Includes W-101 and W-102)
W-101	Watchdog Remote Control
W-102	Watchdog Remote Control Cable
Duct Accessories	
W-103	Watchdog900/900C Return Duct Collar Assembly
W-110	Watchdog900/900C Duct Kit Assembly (Includes W-110 and W-100)
W-120	Watchdog900/900C Duct Kit Assembly (Includes W-103 and W-100)
W-125	Supply Duct, 6" DIA x 72"L Flex Duct

Display/Control Board	
W-150	Watchdog900/900C Main Control Board
W-160	Watchdog Display Board
W-170	Watchdog RH/ Temperature Sensor
Misc. Parts	
W-913	Foot, Adjustable

Internal Components	
W-908	Compressor
W-909	Compressor Capacitor
W-910	Temp/RH Sensor Cable
W-911	Display Ribbon Cable
W-912	Coil Temp Sensor Assembly
W-914	Coil Assembly
W-915	Hot Gas Valve Assembly
W-916	Condensate Pump Assembly
Fan Components	
W-900	Watchdog900/900C Fan Motor
W-901	Watchdog900/900C Complete Fan Assembly
W-902	Fan Capacitor

Filter Components	
W-903	Filter Assembly (Filter cassette with prefilter)
W-904	Watchdog900/900C PreFilter
W-905	Watchdog900/900C Merv 8 Filter
W-906	Watchdog900/900C HEPA Filter
W-907	Watchdog900/900C Carbon Filter

Limited Warranty

All warranty benefits apply to the original owner only. Warranty cannot be transferred or assigned.

1 YEAR (FROM DATE OF PURCHASE): Seaira Global warrants the dehumidifier will operate free of defects in workmanship and materials. At its discretion, Seaira will repair or replace any malfunctioning components, free of charge (excluding transportation costs)

3 YEARS (FROM DATE OF PURCHASE): Seaira Global warrants the refrigeration circuit (compressor, condenser and evaporator) will operate free of defects in material or workmanship. At its discretion, Seaira will replace defective parts, including factory labor or refrigerant. This does not include transportation.

5 YEARS (FROM DATE OF PURCHASE): Seaira Global warrants the compressor, condenser, and evaporator will operate free of any defects in material or workmanship. At its discretion, Seaira will repair or replace the defective parts. This does not include labor, transportation, or refrigerant.

CUSTOMER RESPONSIBILITIES: In order to take advantage of the warranty service, the customer must do the following:

1. Customer must provide normal care and maintenance (including, but not limited to cleaning filters, coils and pumps)
2. Removal and re-installation of unit is the sole responsibility of owner.
3. If customer cannot return unit to certified repair center, all costs associated with freight shipment are borne by the customer. In addition, all duties related to freight shipments, including but not limited to palletizing, wrapping, labeling, and pickup are associated with customer.
4. If shipped, customer is responsible for all risk of loss or damage.

WARRANTY PROCEDURE:

1. Customer must mail in warranty registration card (on page 13) to Seaira Global. If no card is submitted, warranty period will begin the day the shipment left the Seaira warehouse. Please be sure to record serial # and date of installation in the spaces provided on page 2 of the manual. You will need this information to receive an RA number.
2. If warranty service is necessary, customer must contact Seaira Global Tech Support by phone to receive a Return Authorization (RA number).
3. Once an RA has been issued, it is the customer's job to bring the unit to a certified repair center. If this is not an option, shipping will be arranged to bring the unit back to the Seaira warehouse (at the expense of the customer).
4. After the unit has been received by Seaira (whether at a repair center or the warehouse), an initial inspection will be completed, if it is determined to be invalid warranty claim (see exclusions below), unit will be only be completed after receiving payment from customer for all associated costs.
5. If unit is defective, the necessary parts will be repaired or replaced and the unit will be available for pickup at certified repair center or returned via freight shipment (at customer's expense). Keep in mind that work is only done during normal working hours. After being repaired, all units are required to go through a rigorous testing process prior to being returned to customer.
6. Once a part is repaired and the dehumidifier is returned, the original warranty period still applies (no extensions).

Limited Warranty Exclusions

EXCLUSIONS:

DAMAGE DUE TO THE FOLLOWING IS NOT COVERED UNDER WARRANTY

1. ACTS OF NATURE- INCLUDING BUT NOT LIMITED TO:

- FLOODING
- FIRE
- WATER DAMAGE
- HURRICANE/STORM DAMAGE

2. IMPROPER USAGE- INCLUDING BUT NOT LIMITED TO:

- POOL/SPA/TUB APPLICATIONS
- MISUSE, ABUSE, OR TAMPERING WHETHER INTENTIONAL OR ACCIDENTAL
- IMPROPER INSTALLATION OR DESIGN
- IMPROPER VOLTAGE
- LACK OF NORMAL CARE
- FAILURE TO FOLLOW INSTRUCTIONS

3. CORROSION

4. FREEZING

5. ANY ADDITIONAL COSTS DUE TO CHANGES IN LAWS OR BUILDING CODES

6. FREIGHT CHARGES

7. ANY COSTS DUE TO LOST PROFIT OR DELAY

8. DAMAGE TO PROPERTY

9. CAUSE BEYOND CONTROL

10. CONSUMABLE PARTS, INCLUDING BUT NOT LIMITED TO:

- FILTERS
- BATTERIES
- POWER CORDS
- VALVES
- SWITCHES
- RUBBER PARTS

11. DIRECT, INDIRECT, COLLATERAL OR INCONSEQUENTIAL DAMAGES OF ANY KIND

THE WARRANTIES AND LIABILITIES SET FORTH ARE IN LIEU OF ALL OTHER WARRANTIES EXPRESSED OR IMPLIED, IN LAW OR IN FACT, INCLUDING IMPLIED WARRANTIES OF MERCHANTABILITY AND FITNESS FOR PARTICULAR PURPOSE. SEAIRA GLOBAL'S TOTAL LIABILITY, REGARDLESS OF NATURE OF CLAIM SHALL NOT EXCEED ORIGINAL PURCHASE PRICE OF THE PRODUCT. IF A PRODUCT OR COMPONENT IS REPLACED WHILE UNDER WARRANTY, THE APPLICABLE WARRANTY PERIOD SHALL NOT BE EXTENDED BEYOND THE ORIGINAL WARRANTY TIME PERIOD.

THE FOREGOING SHALL CONSTITUTE THE TOTAL LIABILITY OF SELLER IN THE CASE OF DEFECTIVE PERFORMANCE OF ALL OR ANY OF THE EQUIPMENT OR SERVICES PROVIDED TO BUYER. BUYER AGREES TO ACCEPT AND HEREBY ACCEPTS THE FOREGOING AS THE SOLE AND EXCLUSIVE REMEDY FOR ANY BREACH OR ALLEGED BREACH OF WARRANTY BY SELLER.

ANY DISHONESTY OR FRAUD IN CONNECTION WITH SEAIRA GLOBAL WARRANTY THOROUGHLY VOIDS ALL WARRANTY POLICIES. SEAIRA GLOBAL EXPRESSLY RESERVES THE RIGHT TO PURSUE LEGAL ACTION IN THE EVENT OF DISHONESTY, FRAUD, OR ATTEMPTED FRAUD.