

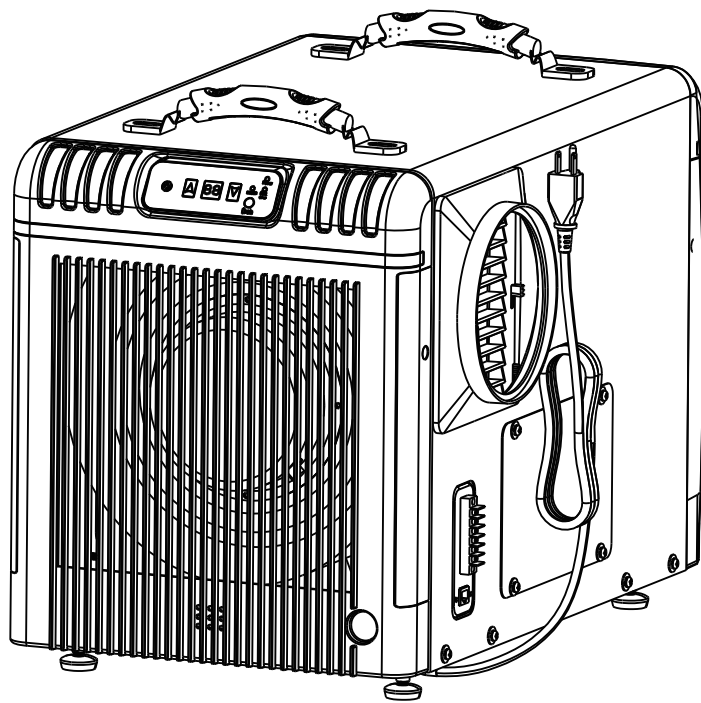

WatchDog 900

Installation and Operations Manual



Seaira Global, LLC

14021 NC Hwy 50, Surf City NC 28445

Phone:(910) 660-0962

Table of Contents

Warranty Registration	2
Safety Notes	2
Identification	3
Electrical Supply	3
Principle of Operation	3
Installation	3
Key Functions	5
Indicator Lights	6
Remote Control	7
Operating Instructions	8
Diagram	8
Maintenance	9
Dehumidifier Storage	9
Ducted Applications	9
Troubleshooting	11
Spare Parts	11
Warranty Information	12

Warranty Registration

Congratulations on purchasing a new Watchdog Dehumidifier. Your new dehumidifier comes with an extensive warranty plan. To register, simply fill in and return the warranty card provided in your dehumidifier box.

Be sure to note your dehumidifier serial number as you will need it for registration.

Safety Notes

- The Watchdog Series Dehumidifier must always be connected using a grounded electrical connection (as required for all electrical appliances). If non-grounded wiring is used, all liability reverts to owner and the warranty is voided.
- Watchdog Dehumidifiers should only be maintained and repaired by a qualified technician.
- Watchdog Dehumidifiers are only intended for operation when oriented with the unit sitting on its feet and level. Operating the unit in any other orientation could allow water to flood electrical components.
- Always unplug the dehumidifier before moving.
- If there is a chance that water flooded the dehumidifier, it should be opened and allowed to dry thoroughly before reconnecting to electrical power and restarting.
- To ensure proper operation, neither the inlet nor discharge should be positioned against a wall. The inlet requires a minimum of 12" clearance and the discharge requires a minimum of 36" clearance.
- The best option for proper diffusion of air throughout the room is to have the discharge blowing away from a wall and the inlet pulling air in parallel to a wall.
- Do not insert your fingers or any objects into the inlet or discharge.
- All work on the dehumidifier should be done with the unit "off" and unplugged.
- Do not use water to clean the exterior. To clean unit, unplug from power, then use a damp cloth to wipe the exterior.
- Do not stand on machine or use as a device to hang clothes.

Identification

For future reference, write down the model, serial number, and date of purchase for your dehumidifier. This is extremely helpful if you need to seek assistance in the future. The data label on the side of your unit has the key characteristics of your specific unit.

Model Number: Seaira Watchdog900

Serial Number:_____ **Date of Purchase:**_____

For additional questions concerning your dehumidifier, the following options are available:

- Contact your installing contractor
- Call Seaira Global @ 910-660-0962

Electrical Supply

Power Supply: 115 V, 60 Hz AC, Single Phase

Outlet Requirement: 3-Prong, GFI

Circuit Protector: 15 Amp

WARNING: 120 Volts AC may cause serious injury from electric shock.

To reduce risk of injury:

1. Disconnect electrical power before servicing
2. Only plug unit into grounded electrical circuit
3. Do not use an extension cord
4. Do not use a plug adapter

Principle of Operation

The Watchdog Series Dehumidifiers utilizes its integral humidistat to monitor the conditioned space. When the relative humidity goes above the selected set point, the dehumidifier will energize. Air is drawn across an evaporator coil, which is cooler than the dew point of air. This means moisture will condense out of the air. The air is then reheated through the condenser coil and distributed back into the room.

Installation

The area to be controlled should be sealed with a vapor barrier. If unit is installed in a crawlspace, all vents should be sealed.

WARNING: Do not install your dehumidifier in a corrosive environment. Some liquid vapor barriers dry via “solvent evaporation”. Always make sure that barrier is completely dry and area is thoroughly ventilated before installing dehumidifier.

Step #1: Place dehumidifier on a level surface.

If the unit is handled in such a manner that the compressor did not remain in the upright position, you will need to place it on a level surface and wait a minimum of 2 hours before turning the unit “on”.

NOTE: Do not place directly on vapor barrier. Elevation is required to allow the condensate water to drain via gravity.

Step #2: Set Up Drain Line

The drain line should be routed to a suitable drain on the outside. It must flow down to the drain without any loops, dips, or valleys.

Recommended Drain Option-Transition to PVC Pipe

1. Cut a piece of 3/4” OD PVC that is approx. 6” long.
2. Insert PVC into a 3/4” elbow, then attach to a 3/4” OD length of PVC to drain. (Note: Keep the length of PVC drain pipe to a minimum)
3. Insert the open end of the tubing into the 3/4” pipe so that it does not extend into the elbow fitting. For proper flow, a minimum downward slope of 1” per 10’ run is required. (Note: If a proper downward angle is not possible, then it is recommended to use a Watchdog900 which includes an integrated condensate pump or utilize an external condensate pump).
4. Support the PVC tubing so that it maintains a smooth downward flow to drain.

5. Always test the drain before leaving installation area.

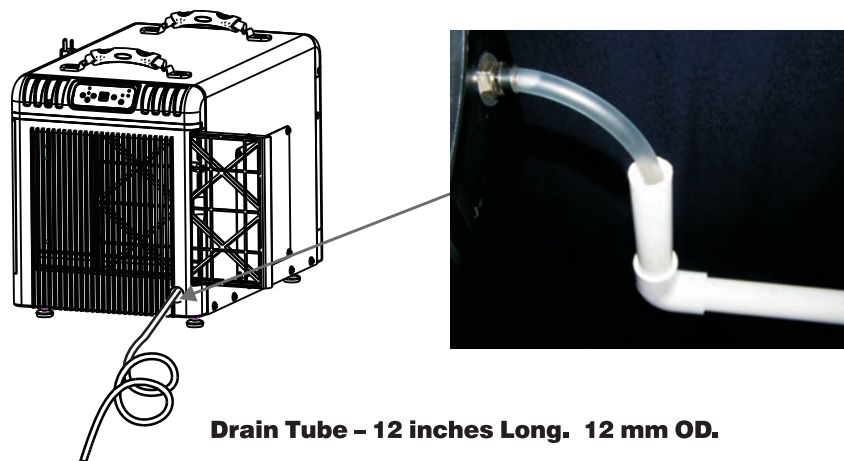

Step #3: Plug unit into 15 amp grounded circuit.

Key Functions

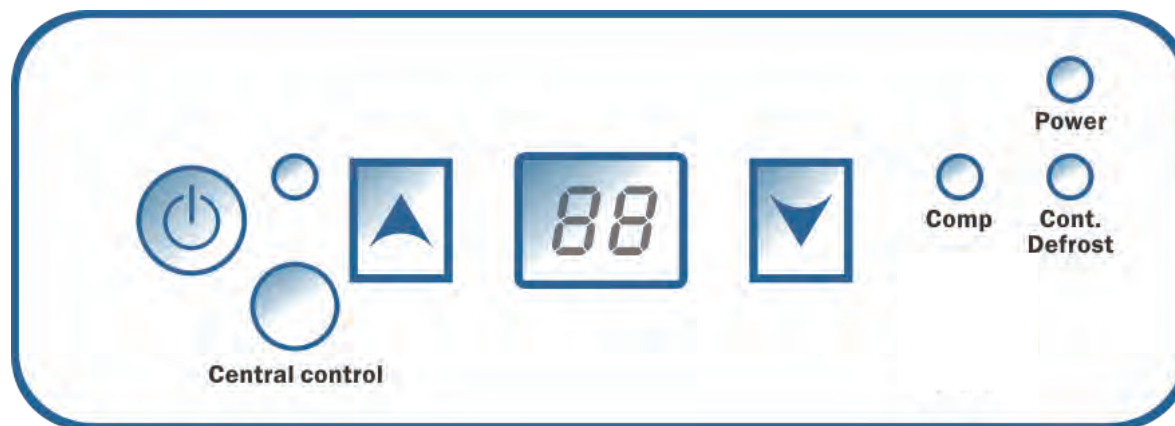

1. Power Key

- Use this button to turn the dehumidifier on and off. Press once to turn machine on. You will hear a beep and the  light will illuminate red. Press the power button a second time and you will hear one beep as the machine shuts down. Note that there is a one minute fan delay on shutdown.

2. Arrow Buttons

- Use the up and down arrow buttons to set the desired humidity setpoint on the display screen.  The setpoint can be any number between 36-90%. Creating a setpoint means that when the indoor humidity is lower than the set point, the machine will stop automatically. Conversely, when the indoor humidity is higher than the set level, the unit will operate. **NOTE: The humidity levels displayed are approximate only (+/- 5%).**

3. Continuous Mode

- To switch into continuous mode, set the humidity below 36%. At this point the Cont. light should illuminate green on the display board to indicate you have successfully switched to continuous mode. The display screen will show "CO".
- When set to continuous, the dehumidifier will run constantly, regardless of the humidity level. To stop the dehumidifier from running, turn the unit off or switch back to normal humidistat operation. To switch back to normal humidistat operation, simply move the setpoint above 36%.

4. Central Control

- This mode is not applicable on the WatchDog 900.

Indicator Lights

1. Humidity Display Screen

- The display screen has two functions:
 1. When the unit is powered on, it shows the indoor humidity.
 2. While setting the desired humidity level, the screen will show the set humidity. After a brief delay, the display will revert to indoor humidity level.

2. Power Indicator Light

- This light indicates that the unit is properly powered on and ready to operate. Always make sure this unit is “off” prior to performing any service.

3. Continuous Mode/AutoDefrost Light

- When this light illuminates green, it indicates that the dehumidifier is set to continuous operation mode.
- When the light glows red, it means the unit is in auto defrost mode and clearing the evaporator coil of any ice buildup.

4. Compressor Light

- When the compressor light glows red, it indicates the compressor has been initiated but is currently warming up.
- Once the compressor light switches to green, it indicates the compressor is in working status.

5. Unit Indicator Light

- When the unit indicator light is red, it illustrates the dehumidifier is in unit mode.

- While in unit mode, the dehumidifier will use its built-in humidity sensor. If using a remote control, unit mode will allow you to remotely monitor the room conditions where the dehumidifier is located.

6. Remote Indicator Light

- When the remote indicator light is red, it illustrates the unit is remote mode.
- While in remote mode, the dehumidifier will use the sensor on the remote control unit. In this mode, the inlet and outlet of the dehumidifier can be ducted

Remote Control Instructions

Watchdog Dehumidifiers can be controlled using an optional remote accessory. The Watchdog Remote Control connects to your Watchdog Series Dehumidifier via a 25' CAT 5 cable. The remote control contains an integrated sensor which gives you multiple options for remotely controlling your unit, in addition to monitoring the conditions surrounding the dehumidifier.

One application for the remote control is to install the dehumidifier in one room with the conditioned air ducted into a second room that contains the remote. For example, the dehumidifier could be installed in a laundry room and ducted into a living room. The remote would then be mounted in the living room so the remote sensor can control the humidity and provide easy controls for the user.

Another useful application for the remote control is if the dehumidifier is in area that's difficult to access on a regular basis. For instance, if your dehumidifier is installed in your crawl space, the remote could be mounted in your living space or garage. This provides you with an easy way to monitor the dehumidifier.

1. On/Off (Power) Button ϕ

Press the on/off button and the machine will start running (two beeps). Press the button again to turn the machine off.

2. Up Button \blacktriangle / Down Button \blacktriangledown

Use the Up and Down arrow buttons to adjust the humidity level.

3. Mode M

Use the Mode button to switch between dehumidification and a ducted application.

- The ϕ symbol on the display board indicates the sensor on the remote control is being utilized.
- The \blacklozenge symbol on the display board indicates the sensor on the dehumidifier is being utilized.

4. Temperature T

Press the temperature button to display the current temperature on the screen. Press the button again to turn off the display.

5. Continuous C

Press this button to switch the unit into continuous mode. **Cont.** will appear on the display to indicate continuous mode.

6. Drain Pump P

Pressing the drain pump button will remove water from the pump reservoir, so the unit can be safely moved or stored.
NOTE: THIS FUNCTION IS ONLY AVAILABLE ON THE WATCHDOG 900c MODEL.

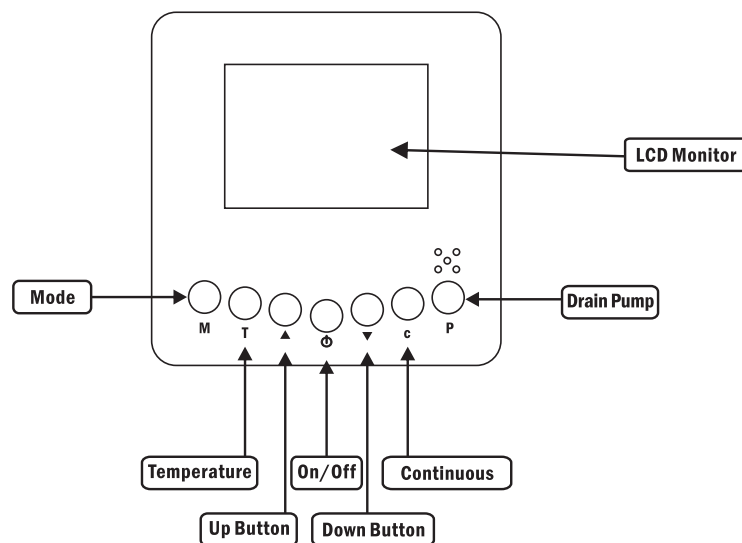

Operating Instructions

1. Start the machine

Press the power key to turn the machine on.

2. Adjust Settings

Use the up and down arrow keys to adjust your desired setpoint (typically 50-55%).

3. Stop the machine

Press the power key again and the machine will stop. The fan will continue to operate for 1 minute after the unit has turned off. NOTE: Do not disconnect power cord to force machine to stop. Always use the power button.

4. Water Drainage

During normal operation, the Watchdog 900 will automatically drain by the force of gravity. If you want to move or store the machine, wait at least 10 minutes to allow machine to completely defrost, then lean gently towards drain to ensure unit is completely drained.

Watchdog 900 Diagram

Front View

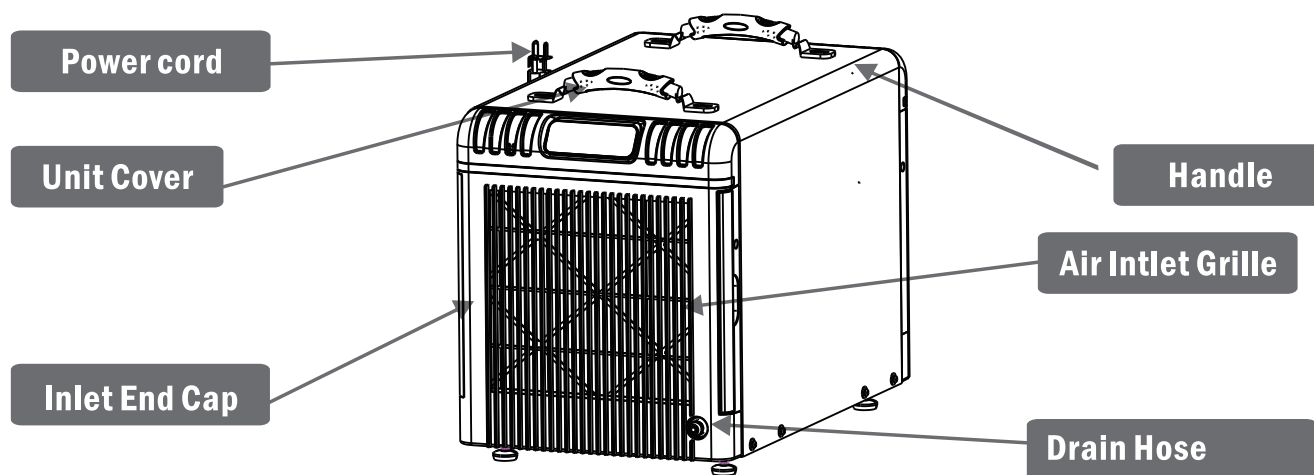

Back View

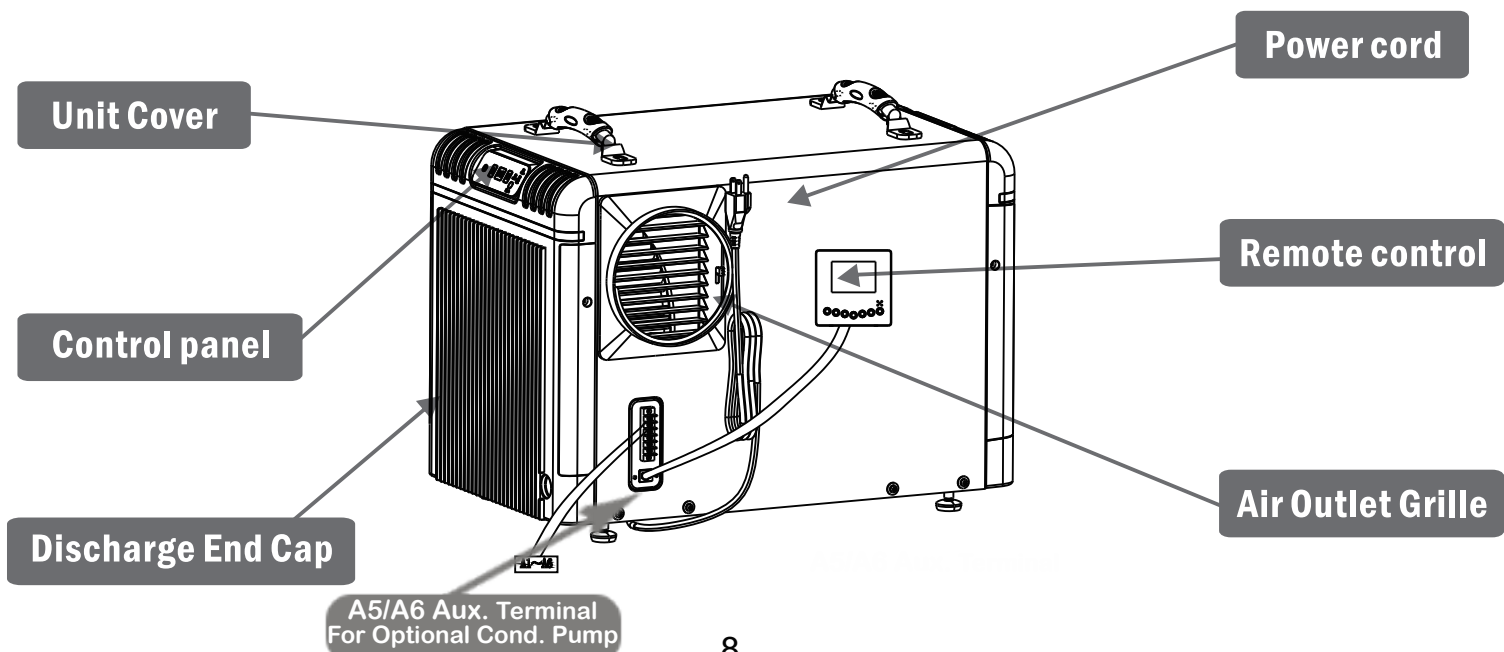

Maintenance

WARNING: Always unplug the unit before doing any maintenance.

☑ Cleaning the machine body

Use a soft damp cloth to clean exterior of unit. Do not use any soap or solvents.

☑ Cleaning the filter

1. Unplug the unit.
2. Slide out the filter.
3. Clean the filter mesh by vacuuming or washing with warm water (no soap or solvents).

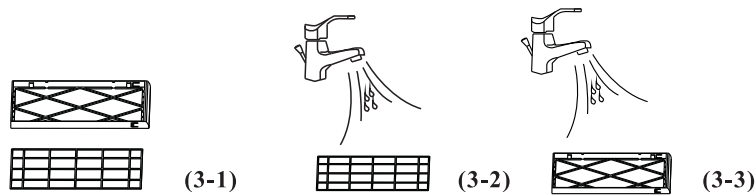
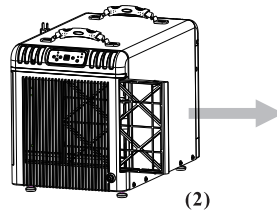

4. Be sure filter is completely dry before restarting unit.

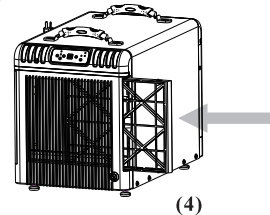

☑ Coil Maintenance

- Once per year, clean the coils with an approved coil cleaner
 - Coil cleaner should be a self rinsing, foaming cleaner such as WEB® Coil Cleaner.

☑ Electrical Maintenance

1. Unscrew the 4 screws on the access panel.
2. Carefully unplug the control board wires
3. Remove the control board.

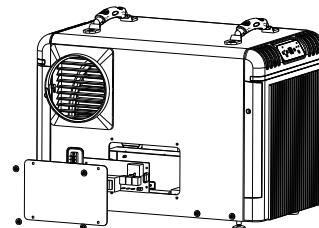

Dehumidifier Storage

If the unit will be stored for an extended period of time, complete the following steps:

1. Turn off the unit and allow to dry
2. Wrap and secure the power cord
3. Cover filter mesh
4. Store in clean, dry space

Ducted Applications

Ducting the dehumidifier allows the unit to be in one room while conditioning an adjacent room. The inlet/return grille is designed for 12" flex ducting while the supply grille is designed for 6" flex ducting.

Be sure to secure the ducting with tie wrap. Also, keep in mind, that the supply ducting can be screwed into an adapter if necessary.

Ducting Installation

- Maximum total length of duct run= 10'
- Maximum length if only ducting inlet or outlet= 6'
- To connect 12" return ducting, it may be helpful to:
 1. Remove inlet grille from end cap
 2. Connect duct to inlet grille
 3. Reconnect inlet grille to end cap

Note: The supply duct adapter is standard on all units.

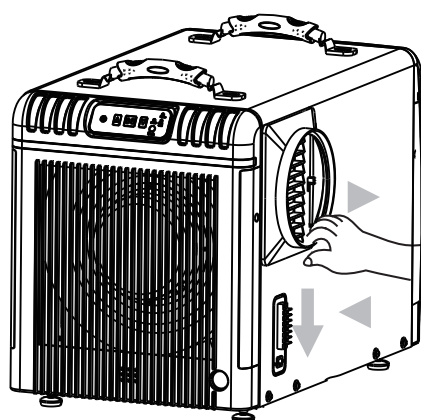

Removing Duct Adapter

If it is necessary to remove the adapter, place hand at bottom of the adapter and use your fingers to pull out and down. This will remove the cover hooks from the machine.

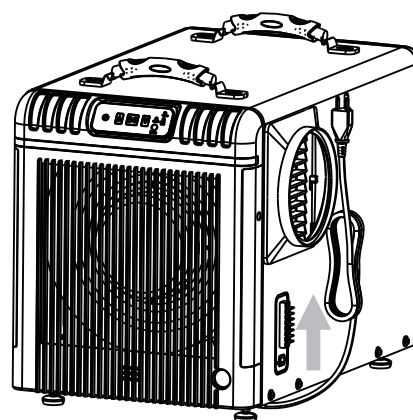

Installing Duct Adapter

To install adapter, line duct up with holes on the side of unit push up from the base of the adapter.

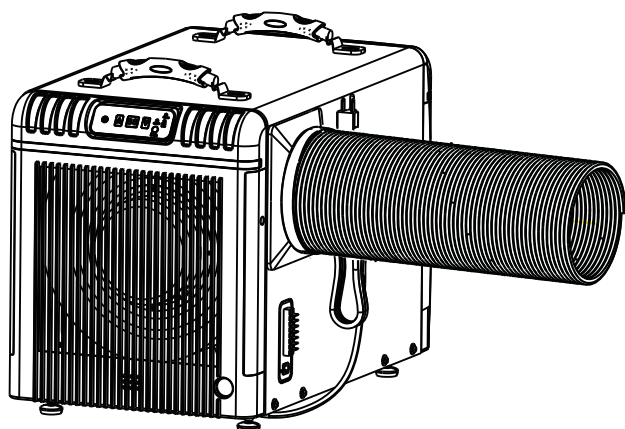

Flex Duct Installation

Rotate the flex duct counter-clockwise.

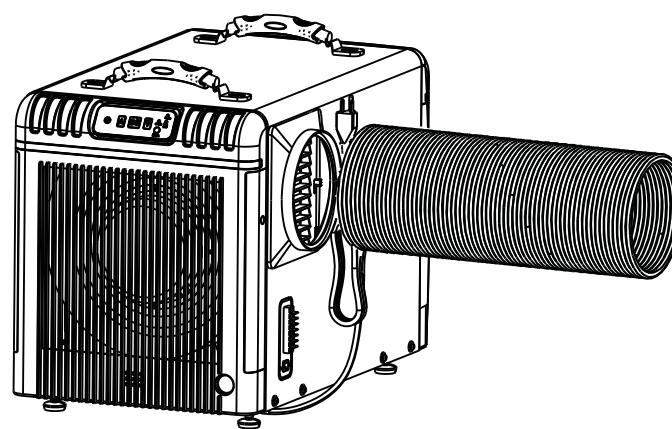

Flex Duct Removal

Rotate flex duct clockwise or remove wire tie.

Troubleshooting

Symptom	Cause	Solution
Machine Won't Run	Power Supply	Verify that there is power to the outlet and that the plug is properly installed in outlet
	Room Temperature Over 105°F (Display HI) or Below 33°F (Display LO)	The unit is outside the operating temperature range. Modify the room conditions so the temperature is between 33°-105°F and operation will commence.
Low Air Flow	Air Filter is Clogged	Clean the filter mesh according to instructions listed in manual.
	Air Inlet or Outlet is Blocked	Clear the blockage from inlet or outlet.
Loud Noise	Machine Is Not Level	Move the dehumidifier to flat, firm ground.
	Filter Mesh is Blocked	Clean the filter mesh according to instructions listed in manual.
Trouble Code E:1	E1=Humidity Sensor Issues	Check to ensure that wire is connected at both ends. If no issues are visible, the sensor may be faulty.
Trouble Code: HI or LO	Room Temperature Over 105°F or Below 33°F (Display LO)	The unit is outside the operating temperature range. Modify the room conditions so the temperature is between 33°-105°F and operation will commence. If room is not out of temperature range, replace faulty sensor.

Spare Parts

Remote Control	
W-100	Remote Control Assembly (Includes W-101 and W-102)
W-101	Watchdog Remote Control
W-102	Watchdog Remote Control Cable
Duct Accessories	
W-103	Watchdog900/900C Return Duct Collar Assembly
W-110	Watchdog900/900C Duct Kit Assembly (Includes W-110 and W-100)
W-120	Watchdog900/900C Duct Kit Assembly (Includes W-103 and W-100)
W-125	Supply Duct, 6" DIA x 72"L Flex Duct

Internal Components	
W-908	Compressor
W-909	Compressor Capacitor
W-910	Temp/RH Sensor Cable
W-911	Display Ribbon Cable
W-912	Coil Temp Sensor Assembly
W-914	Coil Assembly
W-915	Hot Gas Valve Assembly
W-916	Condensate Pump Assembly
Fan Components	
W-900	Watchdog900/900C Fan Motor
W-901	Watchdog900/900C Complete Fan Assembly
W-902	Fan Capacitor

Display/Control Board	
W-150	Watchdog900/900C Main Control Board
W-160	Watchdog Display Board
W-170	Watchdog RH/ Temperature Sensor
Misc. Parts	
W-913	Foot, Adjustable

Filter Components	
W-903	Filter Assembly (Filter cassette with prefilter)
W-904	Watchdog900/900C PreFilter
W-905	Watchdog900/900C Merv 8 Filter
W-906	Watchdog900/900C HEPA Filter
W-907	Watchdog900/900C Carbon Filter

Limited Warranty

All warranty benefits apply to the original owner only. Warranty cannot be transferred or assigned.

1 YEAR (FROM DATE OF PURCHASE): Seaira Global warrants the dehumidifier will operate free of defects in workmanship and materials. At its discretion, Seaira will repair or replace any malfunctioning components, free of charge (excluding transportation costs)

3 YEARS (FROM DATE OF PURCHASE): Seaira Global warrants the refrigeration circuit (compressor, condenser and evaporator) will operate free of defects in material or workmanship. At its discretion, Seaira will replace defective parts, including factory labor or refrigerant. This does not include transportation.

5 YEARS (FROM DATE OF PURCHASE): Seaira Global warrants the compressor, condenser, and evaporator will operate free of any defects in material or workmanship. At its discretion, Seaira will repair or replace the defective parts. This does not include labor, transportation, or refrigerant.

CUSTOMER RESPONSIBILITIES: In order to take advantage of the warranty service, the customer must do the following:

1. Customer must provide normal care and maintenance (including, but not limited to cleaning filters, coils and pumps)
2. Removal and re-installation of unit is the sole responsibility of owner.
3. If customer cannot return unit to certified repair center, all costs associated with freight shipment are borne by the customer. In addition, all duties related to freight shipments, including but not limited to palletizing, wrapping, labeling, and pickup are associated with customer.
4. If shipped, customer is responsible for all risk of loss or damage.

WARRANTY PROCEDURE:

1. Customer must mail in warranty registration card (on page 13) to Seaira Global. If no card is submitted, warranty period will begin the day the shipment left the Seaira warehouse. Please be sure to record serial # and date of installation in the spaces provided on page 2 of the manual. You will need this information to receive an RA number.
2. If warranty service is necessary, customer must contact Seaira Global Tech Support by phone to receive a Return Authorization (RA number).
3. Once an RA has been issued, it is the customer's job to bring the unit to a certified repair center. If this is not an option, shipping will be arranged to bring the unit back to the Seaira warehouse (at the expense of the customer).
4. After the unit has been received by Seaira (whether at a repair center or the warehouse), an initial inspection will be completed, if it is determined to be invalid warranty claim (see exclusions below), unit will be only be completed after receiving payment from customer for all associated costs.
5. If unit is defective, the necessary parts will be repaired or replaced and the unit will be available for pickup at certified repair center or returned via freight shipment (at customer's expense). Keep in mind that work is only done during normal working hours. After being repaired, all units are required to go through a rigorous testing process prior to being returned to customer.
6. Once a part is repaired and the dehumidifier is returned, the original warranty period still applies (no extensions).

Limited Warranty Exclusions

EXCLUSIONS:

DAMAGE DUE TO THE FOLLOWING IS NOT COVERED UNDER WARRANTY

1. ACTS OF NATURE- INCLUDING BUT NOT LIMITED TO:

- FLOODING
- FIRE
- WATER DAMAGE
- HURRICANE/STORM DAMAGE

2. IMPROPER USAGE- INCLUDING BUT NOT LIMITED TO:

- POOL/SPA/TUB APPLICATIONS
- MISUSE, ABUSE, OR TAMPERING WHETHER INTENTIONAL OR ACCIDENTAL
- IMPROPER INSTALLATION OR DESIGN
- IMPROPER VOLTAGE
- LACK OF NORMAL CARE
- FAILURE TO FOLLOW INSTRUCTIONS

3. CORROSION

4. FREEZING

5. ANY ADDITIONAL COSTS DUE TO CHANGES IN LAWS OR BUILDING CODES

6. FREIGHT CHARGES

7. ANY COSTS DUE TO LOST PROFIT OR DELAY

8. DAMAGE TO PROPERTY

9. CAUSE BEYOND CONTROL

10. CONSUMABLE PARTS, INCLUDING BUT NOT LIMITED TO:

- FILTERS
- BATTERIES
- POWER CORDS
- VALVES
- SWITCHES
- RUBBER PARTS

11. DIRECT, INDIRECT, COLLATERAL OR INCONSEQUENTIAL DAMAGES OF ANY KIND

THE WARRANTIES AND LIABILITIES SET FORTH ARE IN LIEU OF ALL OTHER WARRANTIES EXPRESSED OR IMPLIED, IN LAW OR IN FACT, INCLUDING IMPLIED WARRANTIES OF MERCHANTABILITY AND FITNESS FOR PARTICULAR PURPOSE. SEAIRA GLOBAL'S TOTAL LIABILITY, REGARDLESS OF NATURE OF CLAIM SHALL NOT EXCEED ORIGINAL PURCHASE PRICE OF THE PRODUCT. IF A PRODUCT OR COMPONENT IS REPLACED WHILE UNDER WARRANTY, THE APPLICABLE WARRANTY PERIOD SHALL NOT BE EXTENDED BEYOND THE ORIGINAL WARRANTY TIME PERIOD.

THE FOREGOING SHALL CONSTITUTE THE TOTAL LIABILITY OF SELLER IN THE CASE OF DEFECTIVE PERFORMANCE OF ALL OR ANY OF THE EQUIPMENT OR SERVICES PROVIDED TO BUYER. BUYER AGREES TO ACCEPT AND HEREBY ACCEPTS THE FOREGOING AS THE SOLE AND EXCLUSIVE REMEDY FOR ANY BREACH OR ALLEGED BREACH OF WARRANTY BY SELLER.

ANY DISHONESTY OR FRAUD IN CONNECTION WITH SEAIRA GLOBAL WARRANTY THOROUGHLY VOIDS ALL WARRANTY POLICIES. SEAIRA GLOBAL EXPRESSLY RESERVES THE RIGHT TO PURSUE LEGAL ACTION IN THE EVENT OF DISHONESTY, FRAUD, OR ATTEMPTED FRAUD.