

Split System Submittal Data

System: **RE18SKUA** Indoor: **CS-RE18SKUA** Outdoor: **CU-RE18SKUA**
 Single Zone Heat Pump Wall Mounted

Job Name: _____
 Location: _____
 Engineer: _____
 Submitted to: _____
 Submitted by: _____
 Reference: _____

Approval: _____
 Date: _____
 Construction: _____
 Unit#: _____
 Drawing#: _____

General Data	
Power (V/P/Hz)	230/208/1/60
Circuit Ampacity (A)	15
Fuse Size, Max. (A)	20
Compressor	
	DC Twin Rotary (Inverter)
No. Used	1
Motor Type (No. of poles)	DC Brushless (4 poles)
Output Power (W)	900
Outdoor Unit	
Fan Type	Propeller
No. Speeds	Variable speed
Type Drive	Direct / DC Motor
No. Poles (RPM)	8-830
No. Motors (W)	1-40
CFM (Hi speed)	1,485
Coil Type	
	Aluminum Fin Blue Coated
Fin Type - Pipe Type	Corrugated Fin
Rows x stage x F.P.I.	2 x 15 x 21
Size (W x H x L)	1-13/32 x 25-5/8 x 33-5/8
Tube Size (in.)	9/32
Indoor Unit	
Fan Type	Cross Flow
Motor Type, No. of Poles	DC Brushless 8 poles
No. Speeds	Variable speed
RPM (Cool / Heat), High	1,210/1,340
No. Motors (W)	1-47
CFM (Qlo/Lo/Me/Hi/SHi) Cooling	450/498/584/670/725/1485
CFM (Qlo/Lo/Me/Hi/SHi) Heating	488/537/614/695/745/1465
Operating Sound-H/L/QLo/ dB-A (Cool)	48/39/36
Operating Sound-H/L/QLo/ dB-A (Heat)	48/39/36
Coil Type	
	Aluminum (Pre Coat)
Fin Type - Pipe Type	Slit Fin
Row x stage x FPI	2 x 15 x 21
Size	1 x 12-13/32 x 31-7/8
Tube Size (in.)	9/32"
Drain Connection Size (in.)	5/8"
Refrigerant	R410A
OZ. - R410a (outdoor unit)	43.8



Refrigerant Control	Electronic Expansion Valve
Refrigerant Tubing Connections	Flare
Line Length, Max (ft.)	65.6
Elevation Difference, Max (ft.)	49.2
Line Size (in. O.D. Discharge)	1/4"
Line Size (in. O.D. Suction)	1/2"
Pre-charge, tubing length at shipment	24.6'
Dimensions (H x W x D)	
Indoor Unit (Uncrated) (in.)	11-7/16 x 45-5/32 x 9-15/32
Outdoor Unit (Uncrated) (in.)	27-3/8 x 34-15/32 x 12-5/8
Weight (lbs.)	
(Indoor) Net	26lb
(Outdoor) Net	106lb

Performance Data @ ARI Standard Conditions	
High Heating@47° (BTU/H)	18,000
Low Heating@17° (BTU/H)	14,500
Cooling	
Total Capacity (BTU/H)	17,200 (5,800-18,000)
Sensible Capacity (BTU/H)	16,340
Latent Capacity (BTU/H)	860
SEER	16
Dehumidification (Pints/H)	2.7
Amps (A)	6.3
Power Input (W)	1,400
Outdoor Sound Rating (dB-A)	53
Heating	
Total Capacity (BTU/H)	18,000 (5,800-20,800)
HSPF	8.5
Amps (A)	6.2
Power Input (W)	1,380
Outdoor Sounds Rating (dB-A)	54

Features	
Controls	Microprocessor
Remote Controller	LCD Wireless Type included as standard
Wired Remote Controller	Not Available
Temperature Control	IC Thermistor
Timer	Single Event Daily ON/OFF TIMER
Quiet mode	Included
High Power mode	Included
Air Louver, Horizontal	Automatic, Sweep, Step
Air Louver, Vertical	Automatic, Sweep, Step
Power Failure Automatic Restart	Built-In
Heating/Cooling Automatic Changeover	Built-In
Self-Diagnosis	Built-In
Air Filter	Washable, One-touch

Operating Range	Indoor Air Intake Temp	Outdoor Air Intake Temp
Cooling (Max)	89.6F DB/73.4F WB	114.8F DB
Cooling (Min)	60.8F DB/51.8F WB	0F DB
Heating (Max)	86.0F DB	75.2F DB/64.4F WB
Heating (Min)	60.8 DB	-4.0F DB/-2.2F WB



Indoor Dimensions

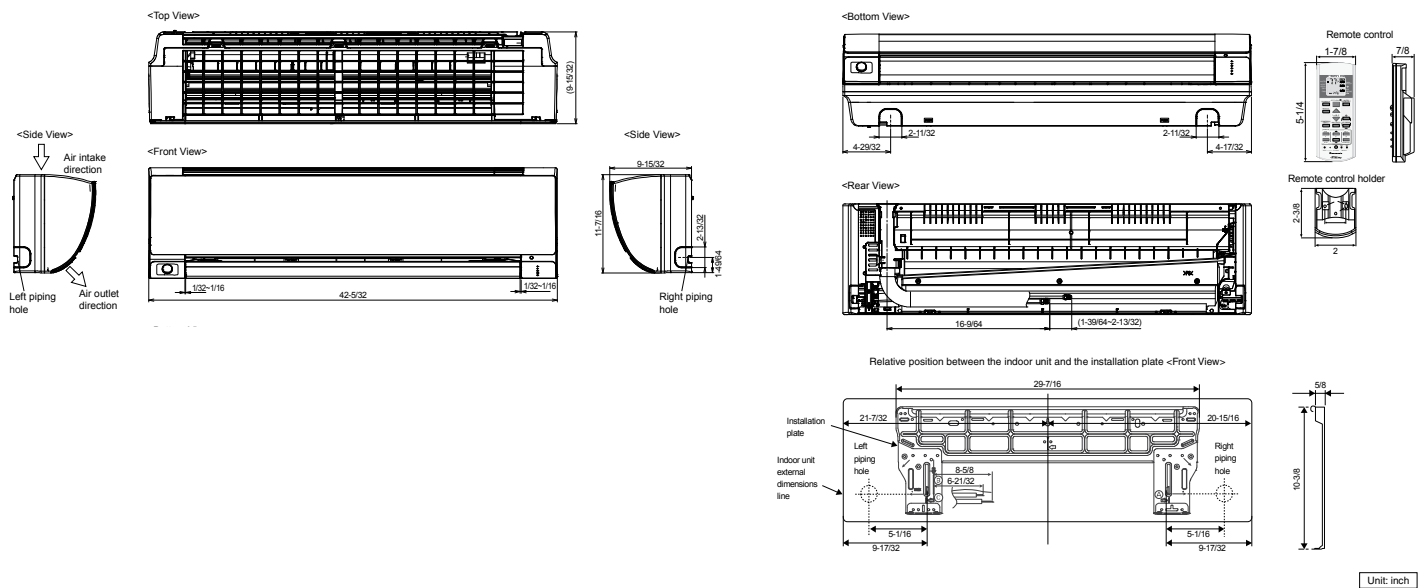

Outdoor Dimensions

