

Application	Primary Zone to Dehumidify	Secondary Zone to Dehumidify	Control Type	Sheet Number	
	Single Zone	Whole House or Basement	N/A	Internal	1
				External	2
	Remote Control (Single Zone)	Crawlspace, Sealed Attic, Storage, Basement	N/A	Remote – Model 76 in the living space	3
	Two Zone <i>(Not recommended in HVAC zoning applications)</i>	Whole house	Basement	Internal	4
				External in Primary	5
	Two Zone <i>(Not recommended in HVAC zoning applications)</i>	Basement	Whole house	Internal	4
				External in Primary	5
	Using the Ventilation Feature			6	

The **Quick Start Guide** is to be used as a reference only. Installation is to be performed by qualified heating and air conditioning professionals in accordance with the Installation Manual provided with the dehumidifier.

# SHEET 1 – SINGLE ZONE USING INTERNAL CONTROL

## PARTS NEEDED (ADDITIONAL PARTS MAY BE REQUIRED)

- Model E080/E100/E130
- Insulated duct
- Duct fittings & hardware
- Grilles (if required)
- Drain pan and float switch (if required)
- Thermostat wire
- 20A outlet (E130 only)

## WIRING INTERNAL CONTROL (SHOWN WITHOUT “DISABLE WITH AC” FEATURE BEING USED)

----- EXISTING WIRE  
 \_\_\_\_\_ NEW WIRE

WIRING TO THE HVAC SYSTEM IS REQUIRED IF DUCTING RETURN TO RETURN, OPTIONAL FOR ALL OTHER INSTALLATIONS.

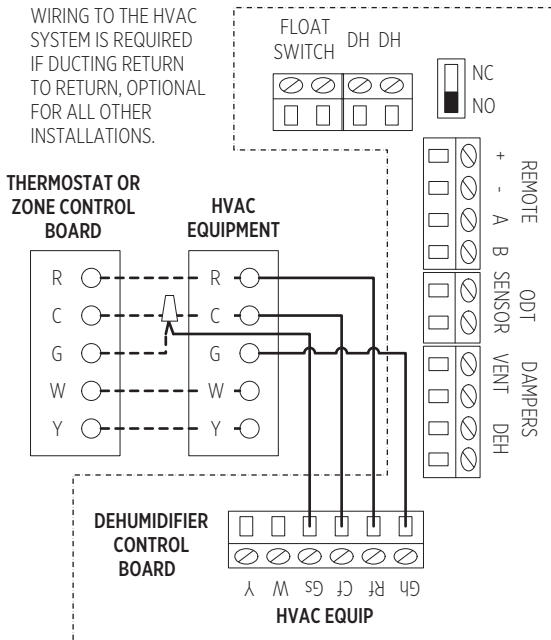

## SEQUENCE OF OPERATION

The dehumidifier will automatically “sample” the air by turning on its blower (and the HVAC blower if this option has been wired – see **WIRING INTERNAL CONTROL** above), and measuring the relative humidity (RH) once every hour. Sampling will also occur when the RH setting is lowered using the ▲ or ▼ buttons on the control.

During sampling, if the RH of the air is above the setting the dehumidifier, the compressor will turn on. The compressor, dehumidifier blower and HVAC system blower (if on) turns off when the RH of the air is 3% RH below the setting.

**FIGURE 1 – DEHUMIDIFIER DUCTED TO HVAC SYSTEM**

### MAIN RETURN TO MAIN RETURN – RECOMMENDED

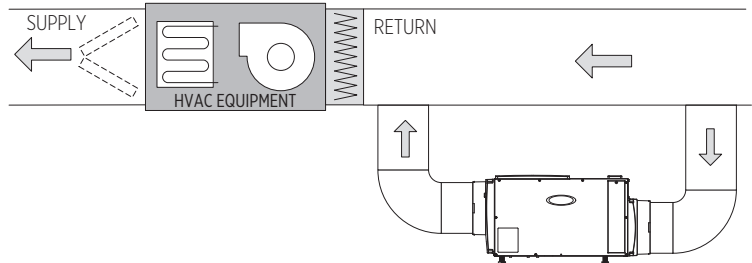

### MAIN RETURN TO MAIN SUPPLY

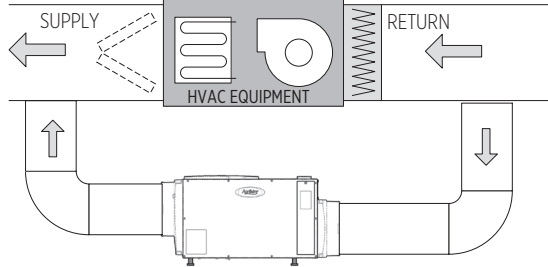

### DEDICATED RETURN TO MAIN SUPPLY OR RETURN

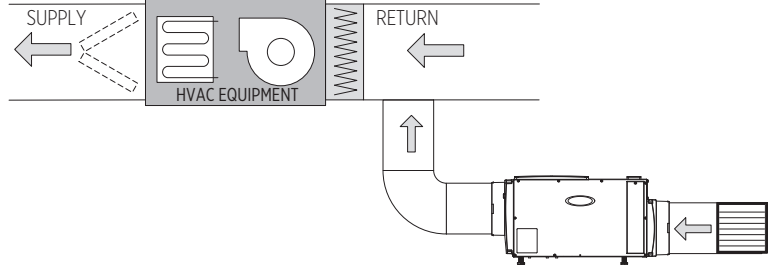

**FIGURE 2 – DEHUMIDIFIER DUCTED DIRECTLY**

### DEDICATED RETURN TO DEDICATED SUPPLY

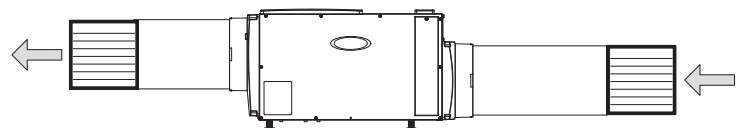

# SHEET 2 – SINGLE ZONE USING EXTERNAL CONTROL

## PARTS NEEDED (ADDITIONAL PARTS MAY BE REQUIRED)

- Model E080/E100/E130
- Insulated duct
- Duct fittings & hardware
- Grilles (if required)
- Drain pan and float switch (if required)
- Thermostat wire
- 20A outlet (E130 only)
- Model 76, Model 8620 or Model 8910 control

## WIRING EXTERNAL CONTROL (SHOWN WITHOUT “DISABLE WITH AC” FEATURE BEING USED)

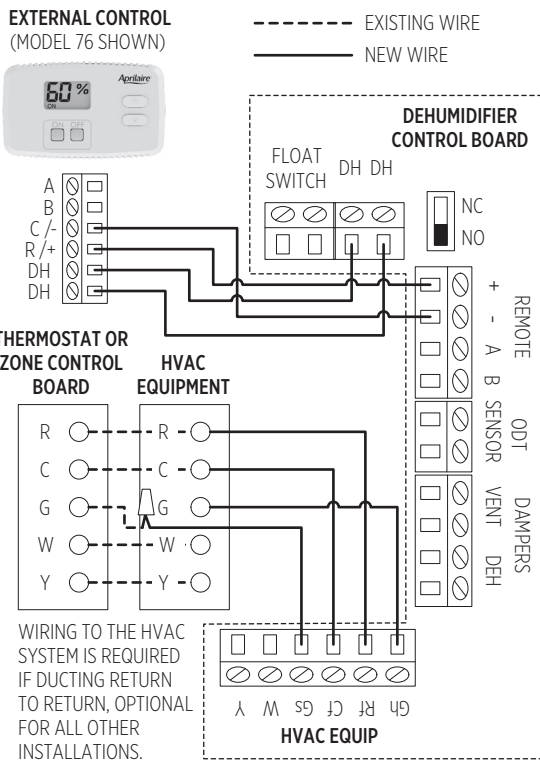

## EXTERNAL CONTROL

The external control (i.e. Aprilaire Model 76 Dehumidifier Control, Model 8620 Thermostat or Model 8910 Home Comfort Control) must have a normally open (NO – all Aprilaire controls are normally open type) or normally closed (NC) dry contact output, and must be installed in the space that is going to be dehumidified. Select the type of control using the NO/NC dip switch on the dehumidifier control.

## SEQUENCE OF OPERATION

When the external control calls for dehumidification, the dehumidifier blower and HVAC blower (if this option has been wired – see **WIRING EXTERNAL CONTROL** above) turn on, then three seconds later the compressor turns on. All will turn off when the external control stops calling for dehumidification.

**FIGURE 1 – DEHUMIDIFIER DUCTED TO HVAC SYSTEM**

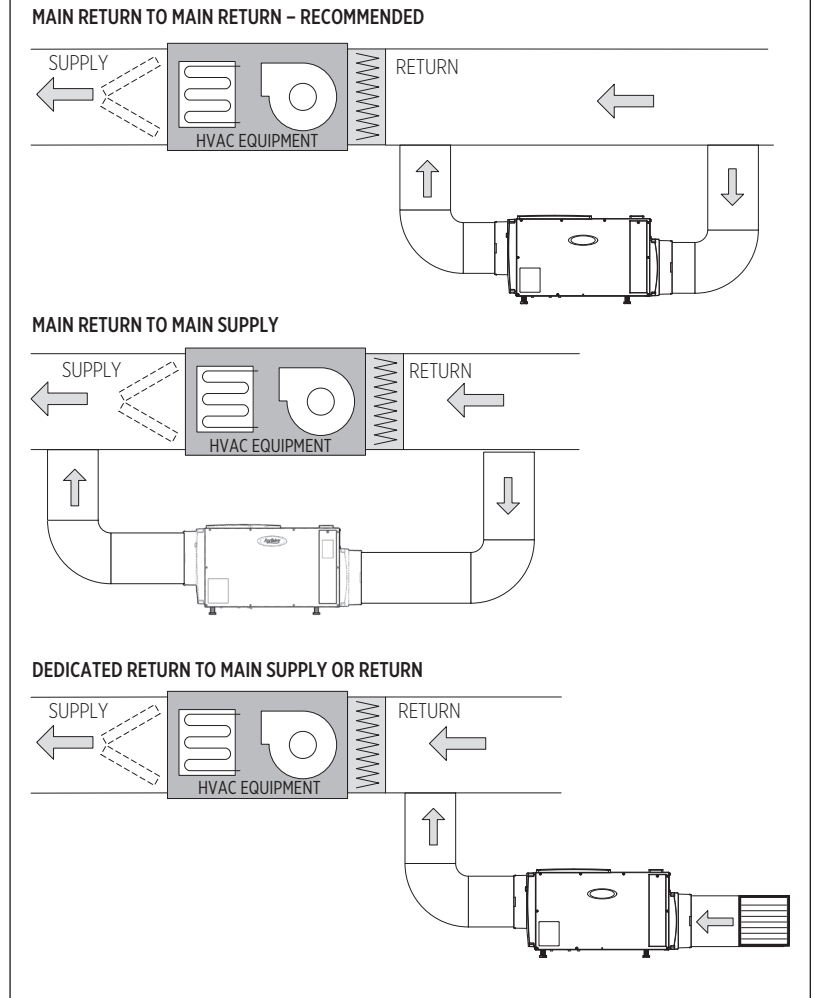

**FIGURE 2 – DEHUMIDIFIER DUCTED DIRECTLY**

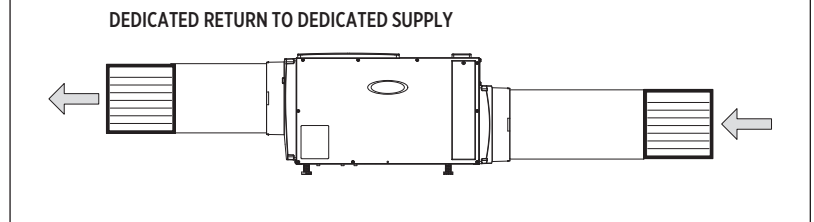

# SHEET 3 – REMOTE CONTROL USING MODEL 76 CONTROL

## PARTS NEEDED (ADDITIONAL PARTS MAY BE REQUIRED)

- Model E080/E100/E130
- Model 76 Dehumidifier Control
- Insulated duct
- Thermostat wire
- Duct fittings & hardware
- 20A outlet (E130 only)
- Grilles (if required)
- Drain pan and float switch (if required)

## WIRING REMOTE CONTROL

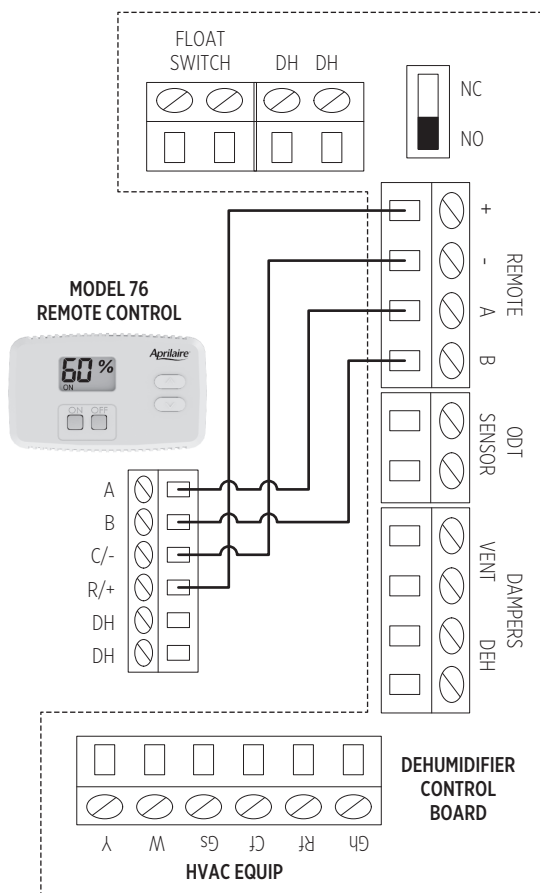
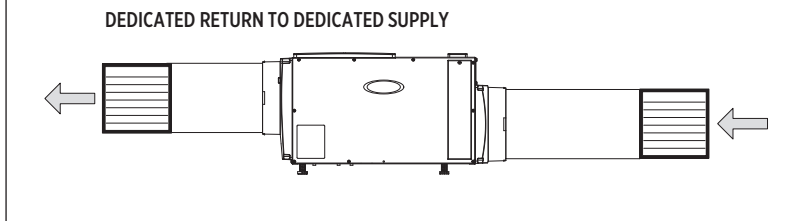

FIGURE 1 – DEHUMIDIFIER DUCTED DIRECTLY



## SET UP THE DEHUMIDIFIER FOR REMOTE CONTROL

After wiring the Model 76 to the dehumidifier as shown, use the power switch located on the outlet panel of the dehumidifier to power up the dehumidifier. The dehumidifier control should display **OFF**.

1. Enter the Installer Set-Up menu by pressing and holding the MODE button on the dehumidifier control for 3 seconds; **REMOTE DISABLED** will appear on the display.
2. Press the ▲ or ▼ button to select **REMOTE ENABLED**.
3. Press the MODE button again to complete set up (**DONE** will appear on the display).

## SEQUENCE OF OPERATION

The Model 76 Dehumidifier Control can be installed in any convenient location within the living space while the dehumidifier is installed in the space that is going to be dehumidified such as a crawl space, attic or basement. The relative humidity (RH) displayed on the Model 76 is the RH in the space where the dehumidifier is located – the dehumidifier communicates this to the Model 76. Changes to the dew point setting (1 = less dry, 7 = more dry) are made at the Model 76 and communicated to the dehumidifier. The dehumidifier can be turned on and off using the ON/OFF buttons of the Model 76.

Once every hour the dehumidifier will turn on its blower and sample the air in the zone to be dehumidified (sampling will also occur whenever the dew point setting is raised). If the dew point of the air is higher than the setting on the control, the dehumidifier compressor will turn on. When the dew point of the air is below the setting on the Model 76 Control, the dehumidifier will turn off.

When the Model 76 Control is wired to the dehumidifier in this application and after completing the set up (see **SET UP THE DEHUMIDIFIER FOR REMOTE CONTROL** above), **REMOTE** will appear on the display of the dehumidifier control.

# SHEET 4 – TWO ZONE USING INTERNAL CONTROL

**Note:** Dehumidifier zoning is not recommended in zoned HVAC applications.

## PARTS NEEDED (ADDITIONAL PARTS MAY BE REQUIRED)

- Model E080/E100/E130
- Insulated duct
- Thermostat wire
- Duct fittings & hardware
- 20A outlet (E130 only)
- Drain pan and float switch (if required)
- Grilles
- 5442 Damper Kit (includes: 2 – 10" dia N.O. dampers, 2 – 10" dia N.C. dampers and one 40VA, 24VAC plug-in transformer)

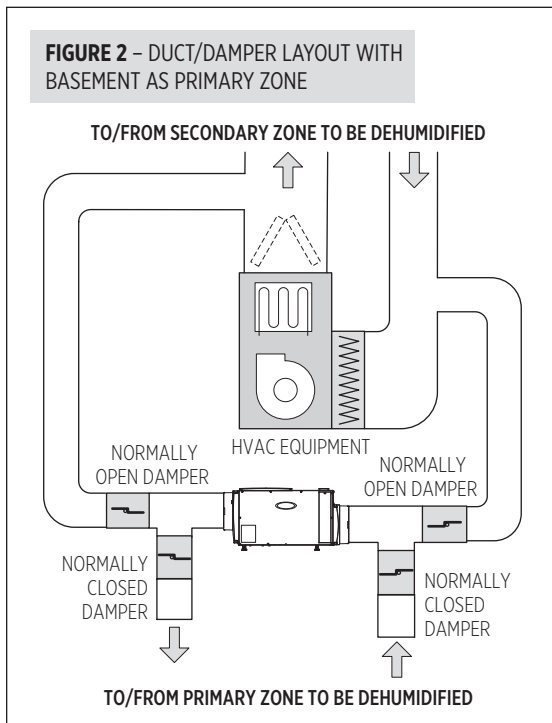
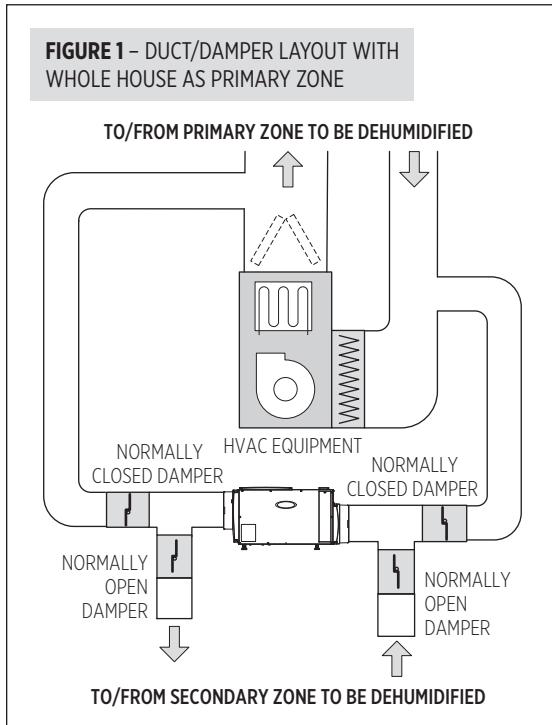

## WIRING INTERNAL CONTROL

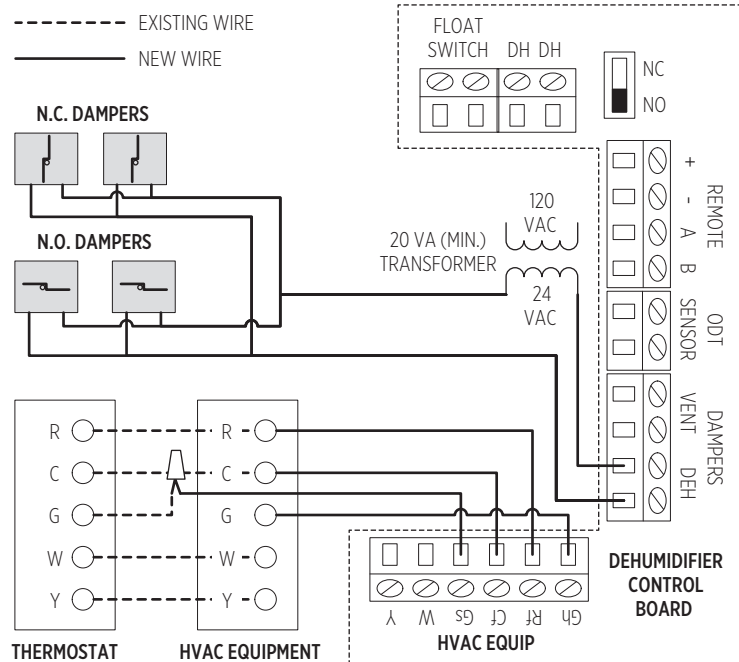

## SEQUENCE OF OPERATION

Adjust the relative humidity (RH) setting on the dehumidifier control; this will be the setting for both the Primary and Secondary Zone. Once an hour, the dehumidifier will “sample” the air in the Primary Zone. If there is no need for dehumidification in the Primary Zone the dehumidifier will then sample the air in the Secondary Zone.

When sampling in the Primary Zone the dehumidifier will energize the dampers and then turn on its blower (and the HVAC System blower if wired as shown in **WIRING INTERNAL CONTROL** above), to measure the RH of the air. If the RH of the air is above the setting, the compressor will turn on. If the Primary Zone does not need dehumidification, the dampers are de-energized and the HVAC System Blower (if on) is turned off while the dehumidifier blower continues to run to sample the air in the Secondary Zone. If the RH of the air in the Secondary Zone is above the setting, the compressor will turn on.

## SET UP THE DEHUMIDIFIER FOR ZONING

1. With **OFF** showing on the control, press the MODE button for 3 seconds to enter the Installer Set Up menu.
2. Press the MODE button until **ZONE DISABLED** appears.
3. Press the ▲ or ▼ button to change to **ZONE ENABLED**.
4. Press the MODE button repeatedly until **DONE** shows on the display.

# SHEET 5 – TWO ZONE WITH EXTERNAL CONTROL IN PRIMARY ZONE

**Note:** Dehumidifier zoning is not recommended in zoned HVAC applications.

## PARTS NEEDED (ADDITIONAL PARTS MAY BE REQUIRED)

- Model E080/E100/E130
- Model 76, Model 8620 or Model 8910 control
- Insulated duct
- Thermostat wire
- Duct fittings & hardware
- 20A outlet (E130 only)
- Drain pan and float switch (if required)
- Grilles
- 5442 Damper Kit (includes: 2 - 10" dia N.O. dampers, 2 -10" dia N.C. dampers and one 40VA, 24VAC plug-in transformer)

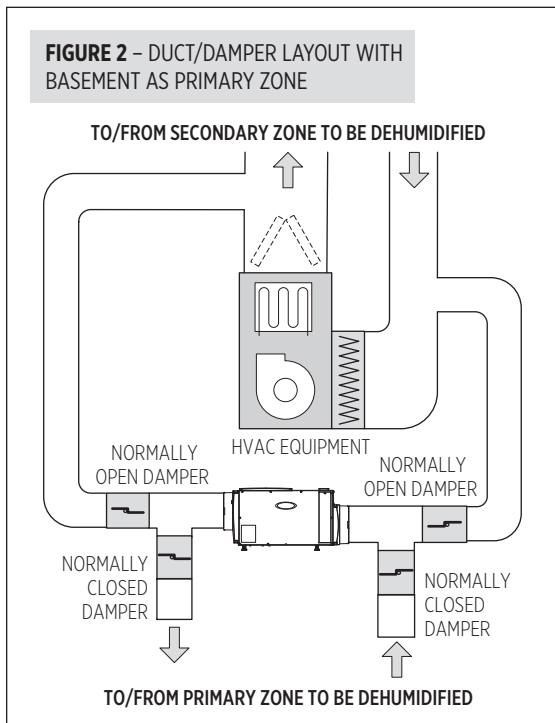
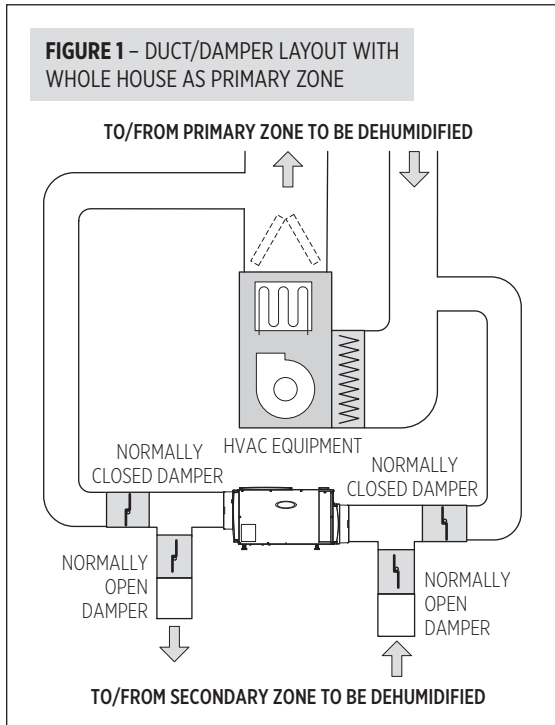

## WIRING EXTERNAL CONTROL IN PRIMARY ZONE

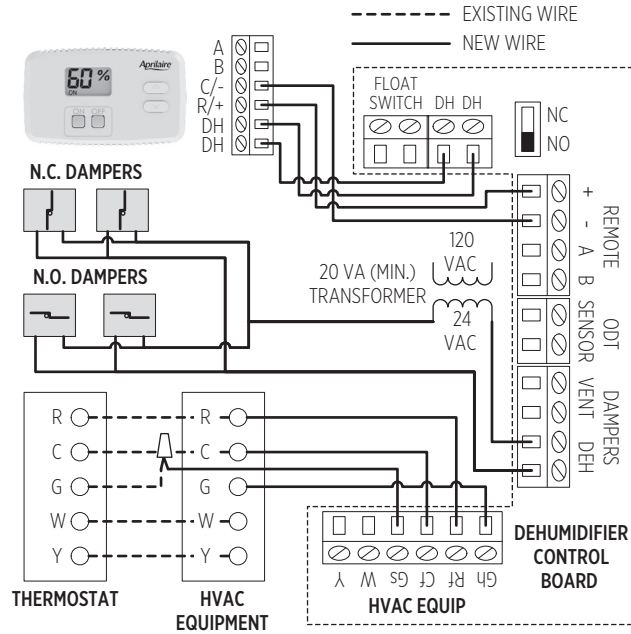

## SEQUENCE OF OPERATION

The external control (i.e. Model 76 Control or Model 8910 Home Comfort Control) provides on-demand control of the dehumidifier for the Primary Zone. When the Primary Zone calls for dehumidification, the dehumidifier energizes the dampers, and turns on its blower and compressor. The dehumidifier will also turn on the HVAC System Blower if wired as shown in **WIRING EXTERNAL CONTROL IN PRIMARY ZONE** above. The Primary Zone demand will override an existing Secondary Zone demand.

The Secondary Zone is controlled by the relative humidity (RH) setting at the dehumidifier control. Once an hour, or immediately after dehumidifying the primary zone, the dehumidifier will “sample” the air in the Secondary Zone. When sampling, the dampers are **not** energized while the dehumidifier blower runs and the RH is measured. If the RH is above the setting on the control, the compressor will turn on and the Secondary Zone will be dehumidified.

## SET UP THE DEHUMIDIFIER FOR ZONING AND EXTERNAL CONTROL

1. Press the MODE button for 3 seconds to enter the Installer Set Up menu
2. Press the MODE button until **ZONE DISABLED** appears.
3. Press the ▲ or ▼ button to change to **ZONE ENABLED**.
4. Press the MODE button again to show **EXTERNAL DISABLED**.
5. Press the ▲ or ▼ button to change to **EXTERNAL ENABLED**.
6. Press the MODE button repeatedly until **DONE** shows on the display.

# SHEET 6 – USING THE VENTILATION FEATURE OF THE DEHUMIDIFIER

## PARTS NEEDED (ADDITIONAL PARTS MAY BE REQUIRED)

- Model 6506 damper
- Model 8052 Outdoor Temperature Sensor (optional)
- Model 4010 10VA transformer
- 6" insulated duct, fittings and hardware
- Intake hood
- Thermostat wire

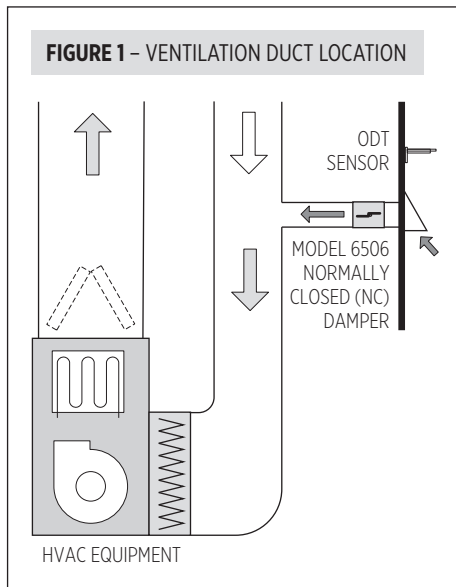

## VENTILATION WIRING

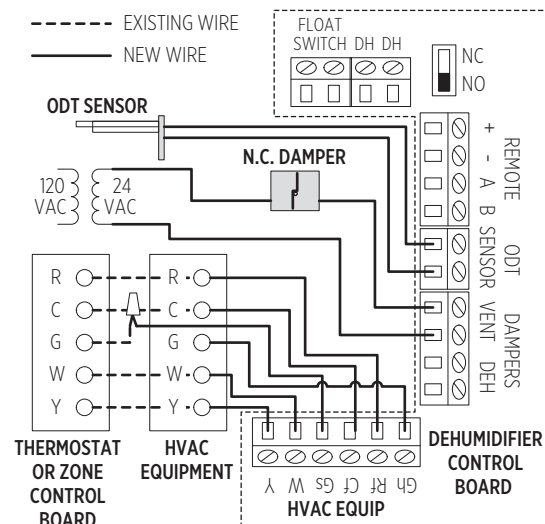

Install a ventilation duct with a normally closed Model 6506 damper to the return duct of the HVAC system (see **FIGURE 1**) and wire the dehumidifier to the HVAC system as shown in **VENTILATION WIRING**. The outdoor temperature (ODT) sensor is used to limit ventilation if the outdoor temperature gets too hot or too cold (see **SET UP THE DEHUMIDIFIER FOR VENTILATION** below). If temperature limits are not needed, the ODT sensor does not have to be installed. Follow the set up instructions below and set the number of minutes per hour that ventilation will be needed (refer to the Installation Manual for details on determining how much ventilation is needed). Whenever the heating or cooling turns on, or when the dehumidifier turns on, the dehumidifier will open the damper and bring in fresh outdoor air. If the equipment doesn't run for the set number of minutes, the dehumidifier will turn on HVAC fan at the end of the hour to ensure ventilation needs are met.

## SET UP THE DEHUMIDIFIER FOR VENTILATION

1. With **OFF** showing on the control, press the **MODE** button for 3 seconds to enter the Installer Set Up menu.
2. Press the **MODE** button until **VENT DISABLED** appears.
3. Press the ▲ or ▼ button to change to **VENT ENABLED**.
4. Press the **MODE** button and **VENT TIMED** will be displayed. Press the ▲ or ▼ button to toggle between:
  - TIMED:** no temperature limits.
  - AUTO – B:** Ventilation not allowed if ODT > 100°F or ODT < 0°F; allowed only when heating if 0°F < ODT < 20°F.
  - AUTO – C:** Ventilation not allowed if ODT > 100°F or ODT < 0°F.
  - AUTO – D:** Ventilation not allowed if ODT > 90°F; allowed only when heating if 0°F < ODT < 40°F.
5. Press the **MODE** button, the use the ▲ or ▼ button to set the Vent Time (minutes/hour).
6. Press the **MODE** button repeatedly until **DONE** appears on the display.

## USING THE DEHUMIDIFIER TO PRE-CONDITION THE VENTILATION AIR

The dehumidifier can be used to remove moisture from the ventilation air **before** it is delivered to the home. Install the ventilation duct to the dehumidifier inlet duct as shown in **FIGURE 2**. The control on the dehumidifier must be used for the Primary Zone (i.e. an external control cannot be used) in this installation. If the RH of the incoming air is above the setting on the control the air will be dehumidified.

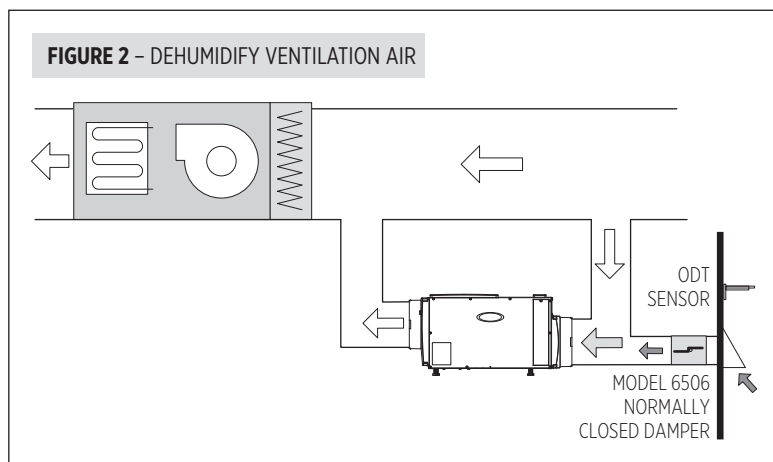

**AprilairePartners.com**

P.O. Box 1467

Madison, WI 53701-1467

800.334.6011 F: 608.257.4357

Printed in USA

©2020 **Aprilaire** – Division of Research Products Corporation

10015107 B2209060A 11.20

**Aprilaire**<sup>®</sup>