

— Restoration & Moisture & Ventilation —

# ALORAIR



## Installation and Operation Manual



warranty/Registrate by scanning

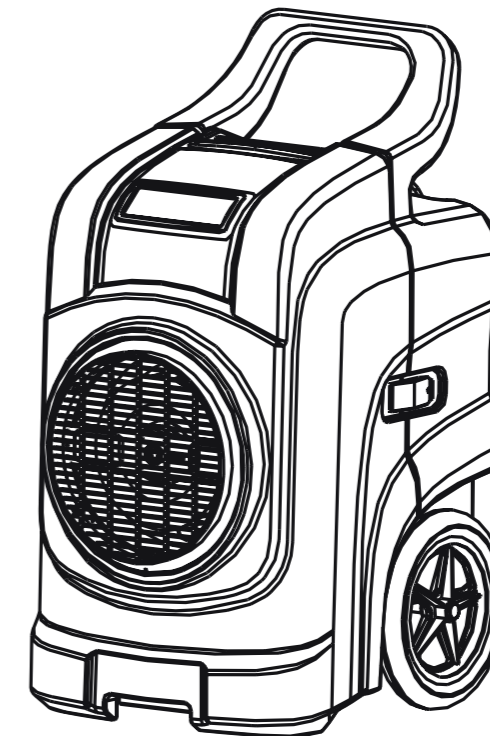

**Storm Elite**

**Alorair Solutions INC.**

Add: 16300 Shoemaker Ave, Cerritos, CA 90703

Tel: 888-990-7469

E-mail: sales@alorair.com

## ※ Safety Notes ※

- The Storm Elite dehumidifier must always be connected using a grounded electrical connection as required for all electrical appliances. The warranty is voided and all responsibility for the operation transfers to the owner if non-grounded wiring is utilized.
- Your Storm Series dehumidifier must be maintained and serviced by qualified technicians.
- Storm dehumidifiers are intended for use only when the unit is installed in a level and upright position. Operating the unit in any other position could cause water to come in contact with the electrical components.
- Before moving the dehumidifier, turn off the unit and allow the pump reservoir to empty (if unit is already off, press “P” button to confirm drain reservoir is empty). After the pump has finished operation, unplug the power cord and relocate the unit to the desired position.
- If the inside of the machine has gotten wet for any reason, the unit should be opened and allowed to dry thoroughly before reconnecting it to electric and restarting.
- For proper operation, neither the inlet or discharge should be positioned against a wall. A minimum of 8” clearance between the Storm and any obstruction is required.
- Do not insert any objects or fingers into the inlet or discharge.
- All work on the machine should be done with the unit off and unplugged.
- Do not spray water or cleaner directly on the exterior of the Elite. Only use a damp cloth to clean the exterior and always unplug the unit first.
- Do not use unit as shelf or device to hang clothes as this could cause damage to unit.
- Do not stand on the machine.

## ※ Table of Contents ※

Introduction.....	01
Unit Overview.....	03
Operating Instructions.....	04
Preparing the Unit for Use.....	09
Maintenance & Repair.....	11
Storing Your Dehumidifier.....	15
Troubleshooting.....	15
Warranty.....	17
Readiness Checklist.....	19
Service Checklist.....	20

## ※ Introduction ※

### Identification

Congratulations on purchasing a Storm Elite dehumidifier! The Storm Elite comes with an extensive warranty plan. To ensure you are eligible, be sure to note the serial number and date of purchase. The serial number can be found on the data on the back of the unit.

**Model Name:**     **Storm Elite**

**Serial Number:** \_\_\_\_\_     **Date of Purchase:** \_\_\_\_\_

### Customer Service

For additional questions concerning the operation fo your dehumidifier, please

- Contact your installing contractor
- Contact Alorair Solutions: 888-990-7469  
sales@alorair.com

### Features

- 125 Pints Per Day
- High COP: 2.4 L/kWh
- Only 63 dBa
- Automatic humidistat
- Built-in Pump with Overflow Protection
- Self Monitoring System
- Eco Friendly R410A Refrigerant
- Easy Access to Internal Components
- Auto Restart After a Power Outage
- Unit Can Be Ducted, If Necessary

## How Your Storm Dehumidifier Works

The Storm Elite dehumidifier utilizes its integral humidistat to monitor the conditioned space. Once conditions are outside the desired setpoint, the compressor energizes and air is drawn across an evaporator coil. The evaporator coil is cooler than the dew point of the air so water vapor will turns into liquid condensation. The air is then reheated through the condenser coil and distributed back into the room.

### Electrical Supply

**WARNING** 240 Volts may cause serious injury from electric shock.

Power Supply:           115V, 60 Hz AC Only 1 Phase  
Outlet Requirement:   3-Prong, GFI  
Circuit Protector:     15 Amp Time Delay Fuse or Circuit Breaker

1. Disconnect electrical power before servicing
2. Only plug unit into grounded electrical outlet
3. Do not use an extension cord
4. Do not use a plug adapter

### Installation

Place the Elite in your desired location. The inlet of the machine should be at least 8" from any obstructions. If the unit has been transported in a horizontal position, allow it to sit in an upright position for at least 30 minutes before operating.

### **WARNING**

Do not use dehumidifier in an environment where corrosive or high VOC materials are applied.

※ Unit Overview ※

Front View

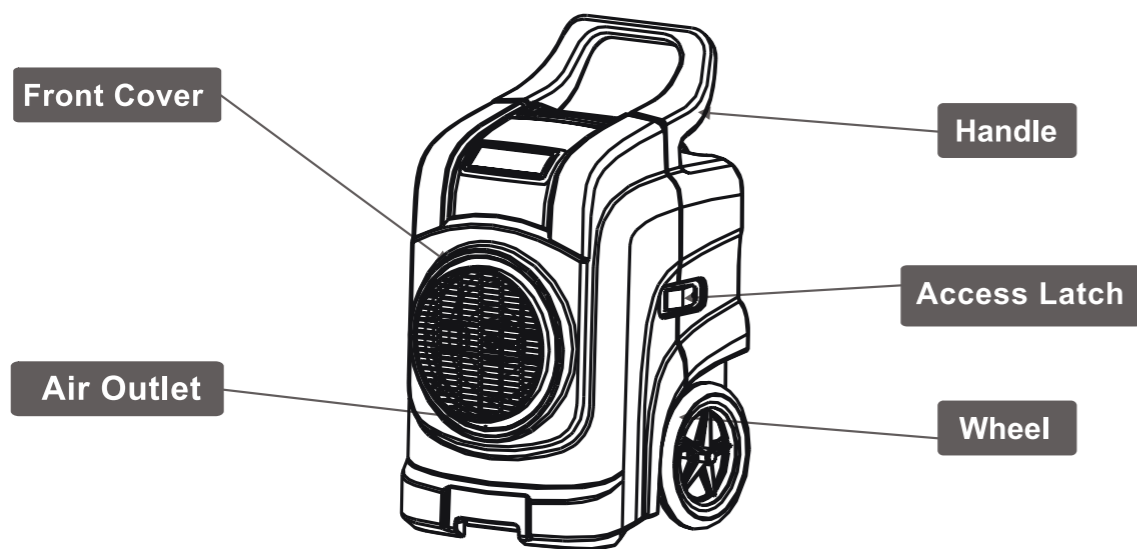

Rear View

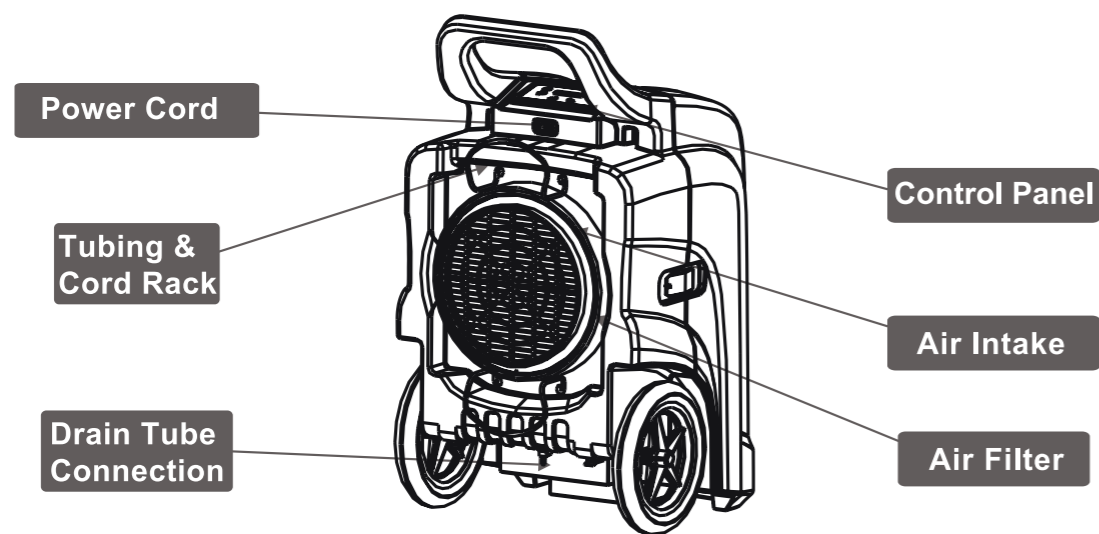

※ Operating Instructions ※

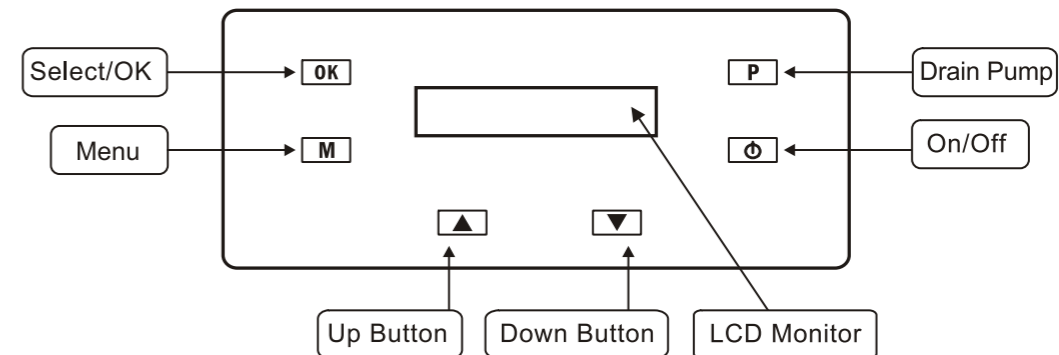

Control Panel Overview

1. On/Off Button 

Press the on/off button once to power the dehumidifier on and begin operation. Once it is powered on, the display will show room humidity levels unless another button is being pressed. To power off the unit, press the on/off button one time.

*NOTE: When the unit is turned off, the fan will run for 1 minute prior to shutting off. In addition, the condensate pump will pump for approximately 15 seconds to drain the reservoir.*

2. Pump Button 

Press the pump button once to remove any water from the integral pump's reservoir. This is useful if you need to move the dehumidifier or plan on storing it for an extended period of time.

3. Menu Button 

Pressing the Menu button gives you the capability to access the settings. Continue pressing the Menu button until your desired selection is flashing. Press the (OK) key to confirm that selection and you will move to a submenu.

After you've completed your task, select "R" (return), then press the (OK) button to move back to the previous menu. Alternatively, you can wait 10 seconds and you will automatically return to the main screen.

**From the main menu you can access:**

- Humidity Settings: Adjust the humidity setpoint
- Timer Settings: Set up auto start time, auto stop time, and time cycles
- Temperature Scale Settings: Choose between Celsius and Fahrenheit for temperature readings

*NOTE: See "How to Change the Settings" for detailed programming instructions*

**4. Select/OK Button** OK

Use this button to confirm a selection.

**5. Up Button** ▲ **Down Button** ▼

The up and down buttons are used to adjust the humidity or timer settings..

**6. LCD Display**

Please note that the LCD monitor will go blank if no buttons are pushed. Push any button to activate the display.

**Understanding the Display Screen**

**1. Display While Turning on the Dehumidifier**

- The display will Show “Power On” when the machine has been plugged in but not started.

				p	o	w	e	r														

- The display will show “Unit On” when the machine is running. This display will change after 2 seconds.

				U	n	i	t															

**2. Display During Operation**

- The LCD interface shows two lines of data. The first line will display the room temperature and humidity.

				I	n		e	t					3	2	°C							

- The second line will alternate between showing the working time (Job T) and Humidity Setpoint.

				J	o	b	·	T					0	0	:	0	5					

or

				H	u	m	i	·	s	e	t											

*NOTE: The second line will change every ten seconds.*

**3. Display During Draining and Defrosting**

- When you press the “P” button to drain the pump, the second line of the display screen will show draining. Draining will also appear during automatic draining while the dehumidifier is operating.

				I	n		e	t					3	2	°C							

- The display will show “defrosting” when the machine is in defrosting mode. If both “Defrosting” and “Draining” are occurring simultaneously, “Defrosting” will show on the screen.

				I	n		e	t					3	2	°C							

**4. Display While Turning off the Dehumidifier**

- When you press the “power off” button, two lines of data will be displayed. The top line will read “Unit Off”. The bottom line will read “Draining” while the pump is being emptied (approximately 15 seconds).

				U	n	i	t															

- Once the pump reservoir has drained, the contents of the second line will alternatively show “job hours” and “total hours”, switching every 10 seconds until the one minute final fan cycle is completed.

				J	o	b	·	T					0	0	:	0	5					

or

				L	i	f	e	·	H					0	0	:	8	9				

**5. Display While Using Timers**

- When one of the timing settings is being used (auto start, auto stop, or timing cycle), that information will show on the second line of the display

Time Remaining Until Auto Start

				T	i	m	e															
--	--	--	--	---	---	---	---	--	--	--	--	--	--	--	--	--	--	--	--	--	--	--

Time Remaining Until Auto Stop

				T	i	m	e															
--	--	--	--	---	---	---	---	--	--	--	--	--	--	--	--	--	--	--	--	--	--	--

Time Remaining Until Cycle Starts

				I	0	0	:	1	0					O	0	0	:	1	0			
--	--	--	--	---	---	---	---	---	---	--	--	--	--	---	---	---	---	---	---	--	--	--

## How to Change the Settings

*NOTE: As long as the machine is plugged into power, the settings can be changed. The unit does not have to be operating to modify the setup.*

### 1. Setting the Humidity Level (Humid)

a. Press the Menu (M) button. The screen will show:

		H	u	m	i	d		T	i	m	e	r		
		T	e	m	p	U								R

b. Press the (M) button until "Humid" is flashing. Press (OK) to select this option. The screen will show:

		H	u	m	i	d		S	e	t	t	i	n	g	
		3	5	%											R

c. Press the menu key until the humidity level (bottom left of display) is flashing. It will either say "Co" for continuous operation or a number for a specific percentage.

d. Use the Up or Down arrows to set the machine to your desired level. Press the (ok) button when finished. The cursor will automatically move to the "R", which will be flashing. Press (ok) to confirm moving to the previous menu or wait 10 seconds and you will automatically return to the main menu.

### 2. Timer Settings (Timer)

This selection allows you to set a timer for the unit to turn on or turn off. You can also set up cycle timing, which lets you set up a repeating cycle of specific on and off durations.

a. Press the menu key several times until the Timer button is flashing. Press the (ok) button to confirm.

		H	u	m	i	d		T	i	m	e	r		
		T	e	m	p	U								R

b. The screen will show: To.on, T.off, T.I/O, R

		T	.	o	n			T	.	o	f	f		
		T	.	I	/	O								R

c. Select your desired option-

**Option 1:** "T. on" – Unit will begin running after a selected amount of time

**Option 2:** "T. off" – Unit will run for designated amount of time and then turn off

**Option 3:** "T. I/O" – Unit will cycle "on" and "off" based on the set time. If unit is off, the cycling will start with unit "off". If unit is on, the cycling will start with the unit "on."

#### Option 1: Start Time (T.on Selection)

a. Press the (M) key until "T.on" is flashing. Press to the OK key to confirm your selection. The screen will then show the first 00 positions flashing.

				T	i	m	e	r		O	n			
				0	0	:	0	0		O	f	f		R

b. Press the Up and Down arrows to select your hour choice between 00-24. Press the (Ok) key to confirm.

c. After the hour selection is confirmed, the minute option will flash. Use the arrow keys to select, then press the (OK) key to confirm.

d. "OFF" will now flash on the screen. Press (OK) one more time, and then "OFF" will switch to "ON". The timer is now set.

#### Option 2: Shut Off Time (T.off Selection)

a. Press the M button until the "T.off" button is flashing. Press (OK) to confirm.

b. Follow instructions as illustrated in 1b-1d to set the timer.

#### Option 3: Cycling Timer (T.I/O Selection)

The third selection, T.I /O, lets you set up the machine to cycle on and off during a specific time frame. For example, you could set the unit to run 8 hours a day and remain off the other 16 hours.

*NOTE: You are selecting on and off periods of time, not set clock times.*

a. Press the(M) button until the T.I/O selection is flashing. Press the (OK) button to select.

b. Use the up and down arrows to adjust the hours and minute of the first cycle.

c. Use the (M )button to move from 1st line of display to the second and then adjust second time period with up and down arrows.

d. Press the (OK) button to confirm the time. (Flashing OFF will turn to ON).

### 3. Temperature Scale Settings

This selection allows you to switch the machine from displaying temperature in degrees Celsius to degrees Fahrenheit.

- a. Press the menu key. The screen will show: Humid, Timer, Tempu, R.

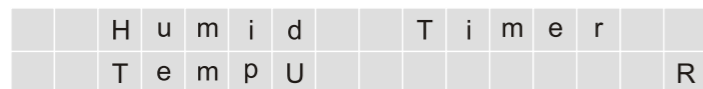

- b. Press the Menu key unit "TempU" flashes. Press (OK) to select.
- c. The screen will show: Celsius degree [°C on/off] and Fahrenheit degree [°F off/on].

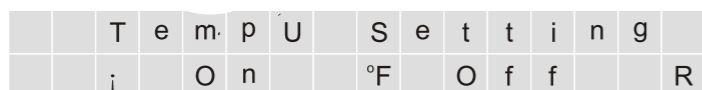

- d. Press the menu key to move the cursor to the [°C on/off] or [°F off/on] (where your cursor is will flash)
- e. Press the (OK) key to confirm. The on/off status of C and F will exchange.

### ※ Preparing the Unit for Use ※

#### Setup

1. Position the machine so there is a minimum of 8" clearance for the back and sides. The front of the unit should be positioned for maximum discharge distance or directly to a specific location for spot dry. If the compressor didn't remain vertical during transportation, wait a minimum of 30 minutes before turning the unit on.
2. The included drain line attaches to the unit via a quick connection fitting that is located on the base of the unit. The drain line should be routed to a suitable drain or outside. Since the unit has an integral drain pump, the drain line may go up vertically (no more than 15') prior to reaching the final drain location.

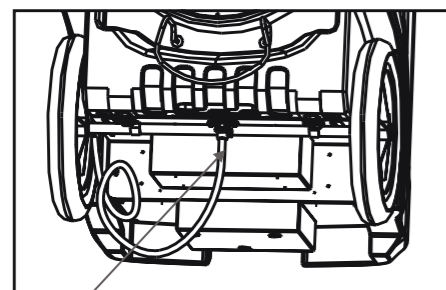

Quick Connection to Drain Tube

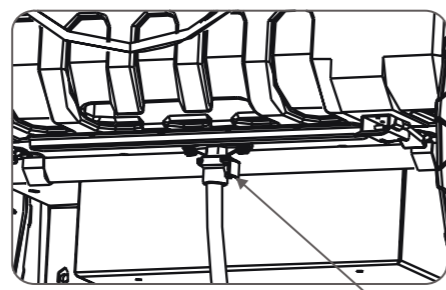

Quick Connect Fitting

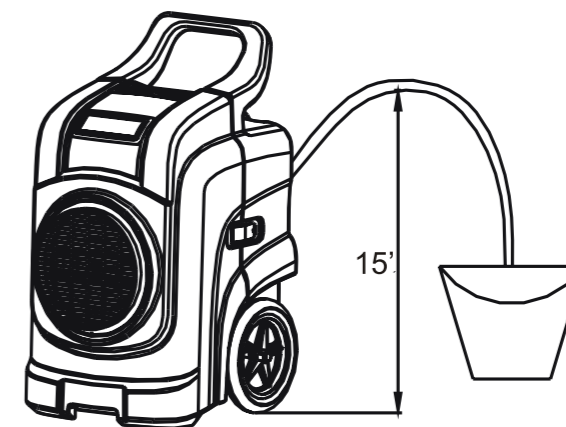

3. Firmly insert the power cord into the socket on back of the unit near the top.
4. Turn on the dehumidifier and use the control panel to set up the dehumidifier as desired

### Optional Duct Installation

Ducting of the unit allows you to condition an adjacent room or focus the discharge to a specific area. The inlet/return grill is designed for 12" flex duct while the supply grille is designed for 12" flex duct or layflat ducting.

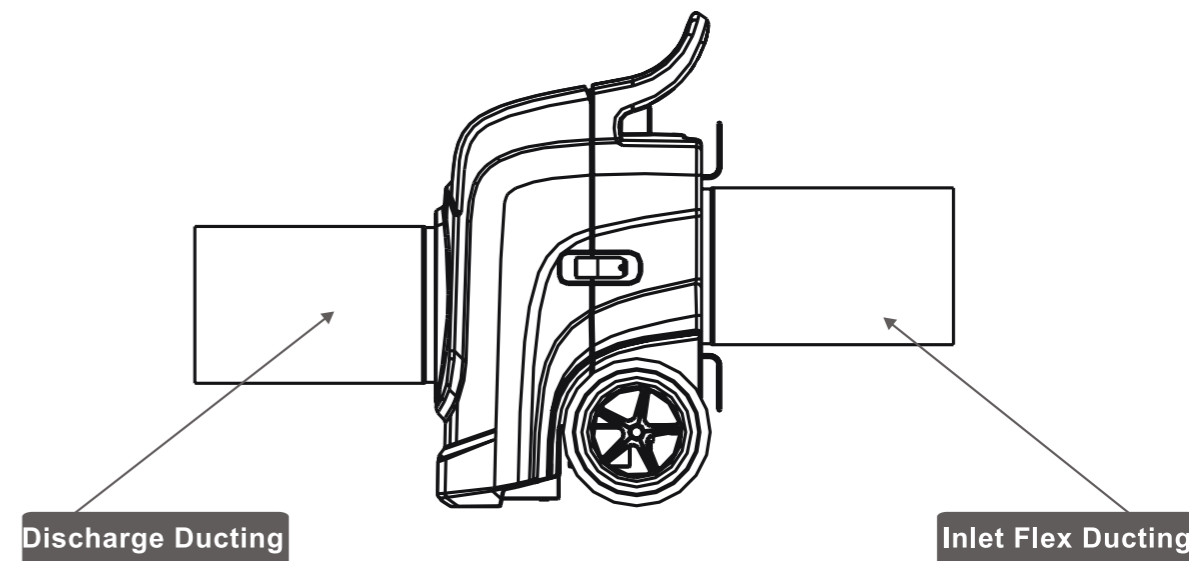

1. Maximum Total Duct Run = 20'
2. Maximum run if only ducting inlet or outlet= 12'
3. It may be helpful to remove the grilles from the end caps when connecting flex duct.

## ※ Maintenance and Repair ※

### Exterior Cleaning

- Use a soft, slightly damp cloth to wipe the plastic body
- Never spray the exterior directly with water or cleaner

### Filter Cleaning

The Elite comes standard with a prefilter and MERV-8 filter, which are washable.

**NOTE:** The carbon filter and HEPA filter (optional accessories) are NOT washable. Replace as needed.

1. To access the filter, rotate the inlet grille counter-clockwise. Remove the filter from the grille.

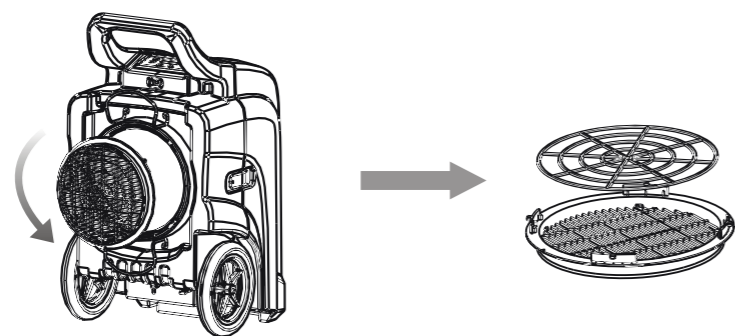

2. You can clean the filter by vacuuming it or rinsing it with warm water (no soap or solvents). Always make sure the filter is dry prior to restarting the unit.

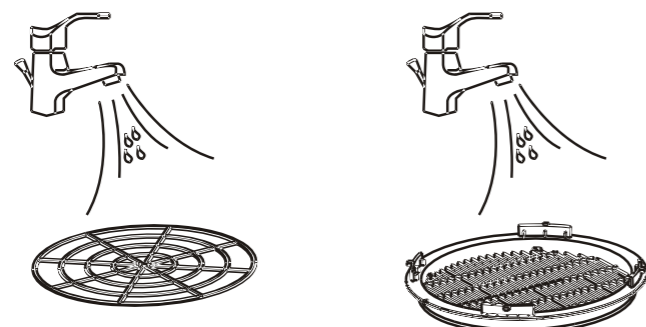

3. Place the filter back in the grille. Reinstall the grill by rotating clockwise.

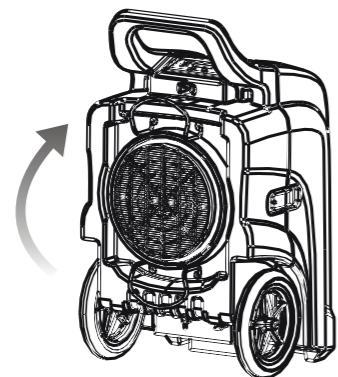

## Accessing Internal Components

**WARNING** Always unplug unit prior to performing any maintenance

1. Remove the screws from the side latches (one per side).

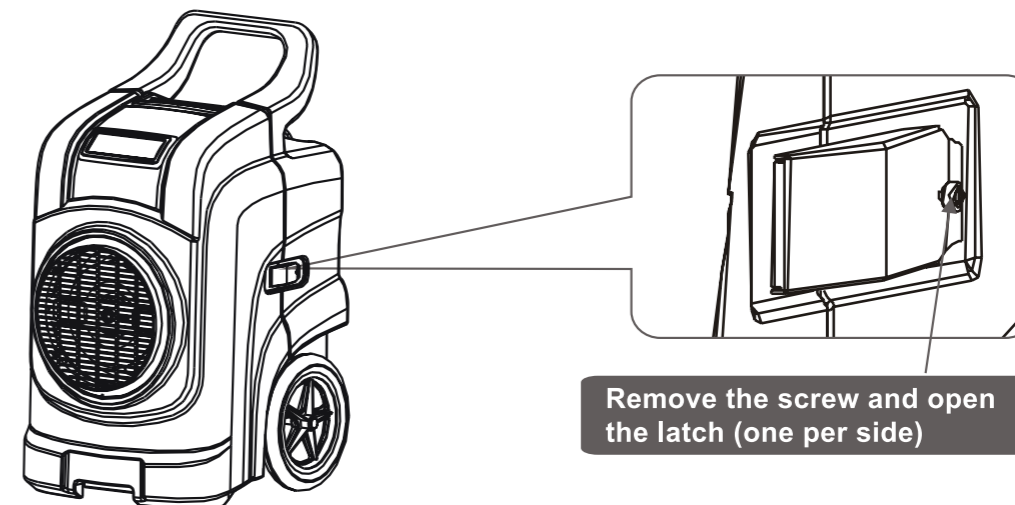

Remove the screw and open the latch (one per side)

2. Undo the two latches on the base of the unit by pressing in the safety then opening the latch.

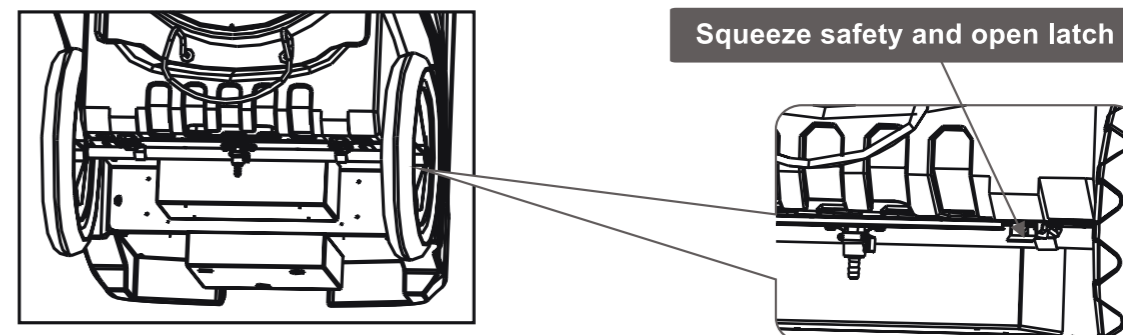

Squeeze safety and open latch

3. Lift open back housing

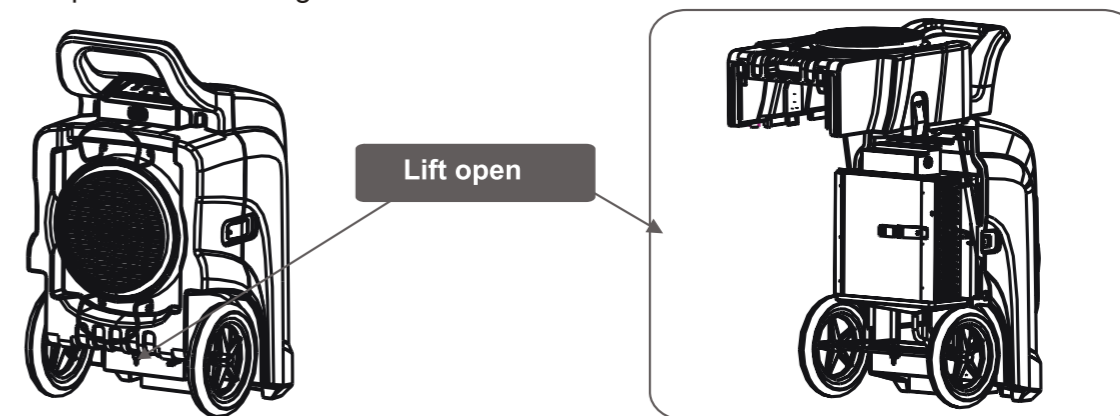

Lift open



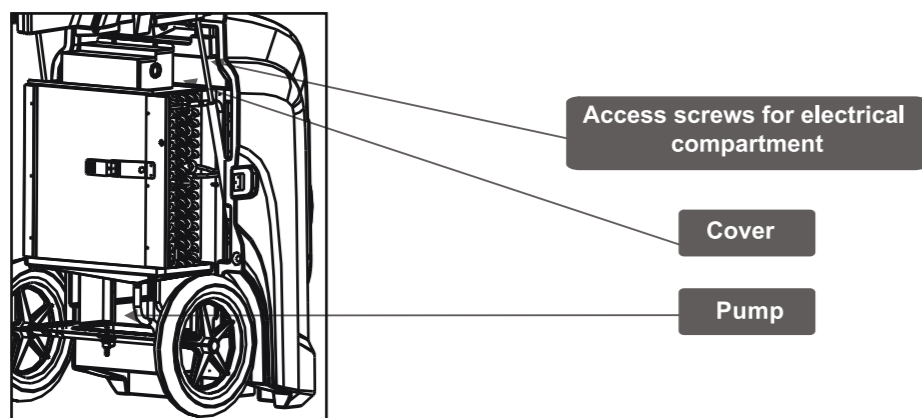

## Integral Pump Maintenance

**NOTE:** This pump requires routine maintenance that is not covered by your 1 year parts warranty. Only a defective pump will be repaired or replaced under the warranty.

As with all pumps, preventative maintenance is necessary to prevent issues from dirt and slime that may accumulate in the drain system. This includes the drain pan, hose to the condensate pump, pump reservoir, pump head, float assembly, and discharge tubing.

The pump is designed with quick connection construction, making it easy to access the pump and components for service and maintenance.

### To Remove Pump from Reservoir:

1. Unplug the unit.
2. Open the back housing as shown on page 12.
3. Remove the condensate tube from the pump.
4. Use the quick connect fittings to disconnect the main power and float switch electrical cables.
5. Use a flathead screw driver to gently pry the the pump off the reservoir.

### At least once per year, clean your pump system.

#### Basic Pump Cleaning:

1. Press the pump button (P) to drain any water from reservoir.
2. Disconnect power to the dehumidifier.
3. Mix a 16 oz cleaning solution of one of the following: 1 oz bleach / 15 oz water or 4 oz white vinegar / 12 oz water. Pour the solution into the drain tray at the base of the coils.

**NOTE:** If you get any cleaning solution on the coils, flush with water.

4. Allow cleaning solution to soak for 15 minutes.
5. Reconnect power to dehumidifier.
6. Pour clean water into reservoir so the pump activates twice (about 16-32 oz. water)
7. Repeat if needed or refer to Advanced instructions.

#### Advanced Pump Cleaning:

1. a. Use the manual pump button (P), to drain any water from reservoir.  
b. Unplug the unit, and remove pump from reservoir (see page 13)  
c. Use a wet dry vac or paper towels to remove any remaining water from the pump reservoir.
2. Fill the pump reservoir with cleaning solution (15 oz water / 1 oz bleach or 12 oz water / 4 oz white vinegar).
3. Reassemble the pump and use the manual pump button to flush the mixture through the discharge tubing.
4. Mix another batch of cleaning solution then pour it slowly into drain pan under evaporator coil and allow it to clean the hose from pan to pump. This process can be stopped when the pump energizes 1 time.  
*NOTE: If you get any bleach/water mixture on coils, flush with water.*
5. Pour sufficient clean water through the drain pan so that the pump activates twice (16-32 ounces).
6. Reassemble the unit and return it to operational status.

## Cleaning the Coils

The coils on your dehumidifier also need to be cleaned once per year. To clean, simply spray with a self-rinsing, foaming coil cleaner (such as WEB Coil Cleaner).

### ※ Storing Your Dehumidifier ※

If you plan on storing your dehumidifier for an extended period of time:

1. Turn unit off and allow to dry.
2. Manually drain pump reservoir.
3. Wrap and secure the power cord .
4. Clean the filter.
5. Store in clean,dry environment.

### ※ Troubleshooting ※

Symptom	Cause	Solution
Display is Blank	Poor Connection	Verify that both ends of the power cord are plugged in
	Power Outage	Reset power
No Airflow	Filter is Dirty	Clean the filter
	Air Inlet or Outlet is Blocked	Clear the blockage
Error Code: E1	Humidity Sensor or Communication Error	Check to ensure that the sensor wire is connected at both ends. if no issues are visible, the sensor may be faulty.
Error Code: E4	Problem with Pump	Verify that the pump is properly installed and functioning. If so, unplug the unit for two minutes, then restart.
Error Code: LO	Room Temperature is below 33F	Increase the room temperature so it is within operating range (above 33F). If er ror still displays, check sensor.
Error Code: HI	Room Temperature is above 105F	Decrease the room temperature so it is within operating range (below 105F). If er ror still displays, check the sensor
E5 Error Code	Refrigerant Leak	Contact Your Installer for Assistance

### Pump Alarm-Error Code E4

If an E4 code appears on the display:

1. Reset the unit by disconnecting the power cord and then reconnecting it .

*NOTE: The unit will not function until the code has been cleared.*

2. Manually check to see if pump is operational by pressing the drain button. Verify that the pump energizes and de-energizes properly. Additionally, check to see if any water purged from the system.
3. If you haven't cleaned the system recently, check the discharge line for an obstruction, then clean the balance of the pump system (see "Maintenance" section for details).
4. Replace the hoses and/or pump, if maintenance alone isn't sufficient.

## ※ Warranty ※

All warranty benefits apply to the original owner only. Warranty cannot be transferred or assigned.

**1 YEAR (FROM DATE OF PURCHASE):** Alorair Solutions warrants the dehumidifier will operate free of defects in workmanship and materials. At its discretion, Alorair will repair or replace any malfunctioning components, free of charge (excluding transportation costs)

**3 YEARS (FROM DATE OF PURCHASE):** Alorair Solutions warrants the refrigeration circuit (compressor, condenser and evaporator) will operate free of defects in material or workmanship. At its discretion, Alorair will replace defective parts, including factory labor or refrigerant. This does not include transportation.

**5 YEARS (FROM DATE OF PURCHASE):** Alorair Solutions warrants the compressor, condenser, and evaporator will operate free of any defects in material or workmanship. At its discretion, Alorair will repair or replace the defective parts. This does not include labor, transportation, or refrigerant.

**CUSTOMER RESPONSIBILITIES:** In order to take advantage of the warranty service, the customer must do the following:

1. Customer must provide normal care and maintenance (including, but not limited to cleaning filters, coils and pumps)
2. Removal and re-installation of unit is the sole responsibility of owner.
3. If customer cannot return unit to certified repair center, all costs associated with freight shipment are borne by the customer. In addition, all duties related to freight shipments, including but not limited to palletizing, wrapping, labeling, and pickup are associated with customer.
4. If shipped, customer is responsible for all risk of loss or damage.

### AlorAir Warranty Steps:

1. Once receive the goods, customers must log in [www.alorair.com](http://www.alorair.com) to fill out the warranty registration form and submit to AlorAir company. We will receive your purchasing and installation information and save it. If no warranty registration is sent to us, warranty period will begin the day the shipment left the warehouse. Please be sure to record serial # and date of installation. You will need this information to receive the RA number.
2. If warranty service is necessary, customers must contact Alorair Tech Support by [sales@alorair.com](mailto:sales@alorair.com) or local technical service phone to receive a Return Authorization (RA number). Once an RA has been issued, customers should bring the unit to a certified repair center. AlorAir will arrange the shipping to bring the unit back to the Alorair warehouse (at the expense of the customers) if customers are not available.
3. After the unit has been received by Alorair (whether at a repair center or the warehouse), Alorair will have an initial inspection. If it is determined to be invalid warranty claim (see exclusions below), customers have to pay for all associated repair costs and shipping costs for units repair.
4. Customers can pick up the unit after repair at their own expense for shipping. Units will have a rigorous testing before sending it back to customers
5. If the unit can no longer be fixed, and it is in the warranty period and determined to be valid claim, we will ship the customer a new unit within the same year warranty from the date of replacement.
6. After parts are repaired or replaced by AlorAir, the original warranty period continues to apply until meet its deadline. No extensions to the original warranty period.

## Limited Warranty Exclusions

DAMAGE DUE TO THE FOLLOWING IS NOT COVERED UNDER WARRANTY

1. ACTS OF NATURE- INCLUDING BUT NOT LIMITED TO:
  - FLOODING
  - FIRE
  - WATER DAMAGE
  - HURRICANE/STORM DAMAGE
2. IMPROPER USAGE- INCLUDING BUT NOT LIMITED TO:
  - POOL/SPA/TUB APPLICATIONS
  - MISUSE, ABUSE, OR TAMPERING WHETHER INTENTIONAL OR ACCIDENTAL
  - IMPROPER INSTALLATION OR DESIGN
  - IMPROPER VOLTAGE
  - LACK OF NORMAL CARE
  - FAILURE TO FOLLOW INSTRUCTIONS
3. CORROSION
4. FREEZING
5. ANY ADDITIONAL COSTS DUE TO CHANGES IN LAWS OR BUILDING CODES
6. FREIGHT CHARGES
7. ANY COSTS DUE TO LOST PROFIT OR DELAY
8. DAMAGE TO PROPERTY
9. CAUSE BEYOND CONTROL
10. CONSUMABLE PARTS, INCLUDING BUT NOT LIMITED TO:
  - FILTERS
  - BATTERIES
  - POWER CORDS
  - VALVES
  - SWITCHES
  - RUBBER PARTS
11. DIRECT, INDIRECT, COLLATERAL OR INCONSEQUENTIAL DAMAGES OF ANY KIND

THE WARRANTIES AND LIABILITIES SET FORTH ARE IN LIEU OF ALL OTHER WARRANTIES EXPRESSED OR IMPLIED, IN LAW OR IN FACT, INCLUDING IMPLIED WARRANTIES OF MERCHANTABILITY AND FITNESS FOR PARTICULAR PURPOSE. ALORAIR SOLUTIONS'S TOTAL LIABILITY, REGARDLESS OF NATURE OF CLAIM SHALL NOT EXCEED ORIGINAL PURCHASE PRICE OF THE PRODUCT. IF A PRODUCT OR COMPONENT IS REPLACED WHILE UNDER WARRANTY, THE APPLICABLE WARRANTY PERIOD SHALL NOT BE EXTENDED BEYOND THE ORIGINAL WARRANTY TIME PERIOD.

THE FOREGOING SHALL CONSTITUTE THE TOTAL LIABILITY OF SELLER IN THE CASE OF DEFECTIVE PERFORMANCE OF ALL OR ANY OF THE EQUIPMENT OR SERVICES PROVIDED TO BUYER. BUYER AGREES TO ACCEPT AND HEREBY ACCEPTS THE FOREGOING AS THE SOLE AND EXCLUSIVE REMEDY FOR ANY BREACH OR ALLEGED BREACH OF WARRANTY BY SELLER.

ANY DISHONESTY OR FRAUD IN CONNECTION WITH ALORAIR SOLUTIONS WARRANTY THOROUGHLY VOIDS ALL WARRANTY POLICIES. ALORAIR SOLUTIONS EXPRESSLY RESERVES THE RIGHT TO PURSUE LEGAL ACTION IN THE EVENT OF DISHONESTY, FRAUD, OR ATTEMPTED FRAUD.