



F395 Owner's Manual HygroTrac™ Sensor Extension Kit

Air Marketing Group LLC
141 Kinderkamack Road
Park Ridge, New Jersey 07656
Phone: 201-782-1782 Fax: 201-782-1783 www.amgair.com

This sensor extension kit modifies the sensing capacity of the GE Protimeter HygroTrac Remote Wireless Monitoring System so that each HygroTrac sensor can monitor up to three points.

READ AND SAVE THESE INSTRUCTIONS

Read and understand manual before installing.

INTRODUCTION

This kit enables any HygroTrac sensor monitor three Moisture Content (MC) points instead of just one point from each sensor by itself. The sensor extensions can be used in two ways:

1. Sensors mounted in dehumidifier outlets or HVAC grills to collect humidity and temperature data can now be modified to collect moisture data in nearby materials at the same time.
2. Similarly, sensors installed to measure atmospheric conditions in specific spaces (such as a bedroom or crawl space) can be modified to collect moisture data from nearby materials.

Installation

This Sensor Extension Kit includes enough parts to modify three HygroTrac sensors. For additional Extension Kits, contact your local Dri-Eaz distributor or call 800-932-3030.

Sensor Setup

Refer to Figures 1 and 2, right

1. Place a flat washer on each of the 2" machine screws. Holding the HygroTrac sensor upright, drop the screw/flat washer combinations through the screw tunnels of the sensor.
2. On the other end of each screw, place a flat washer, the ring terminal of a wire harness and a second flat washer, then gently secure it with the K-Lock Nut. When tightening the K-Lock Nut, use enough pressure so that the screwhead/washer will make firm contact with the HygroTrac's contact ring. Take care not to over-tighten, as this may damage the sensor.

Figure 1

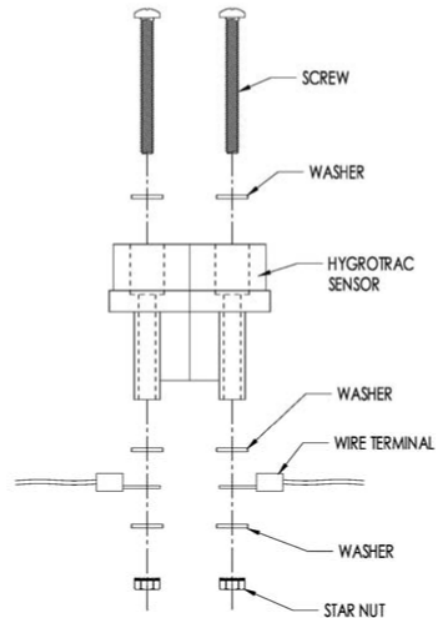
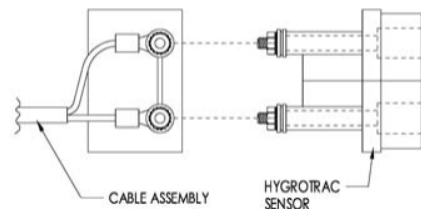

Figure 2



Installation for wood moisture readings:

Refer to Figure 3, below.

1. Wood moisture readings are best taken with wood screws driven into the wood. To attach them to the harness, place a (split) spring lock washer (provided with the HygroTrac) on the screw and drive it through the ring terminal in the wire harness. Avoid over-tightening the screws, as this may damage the ring terminals and/or wires.
2. Additional reading points may be achieved by linking together additional wire harnesses and screws or pins as shown in Figure 3. **Note:** Only one type of fastener (screws or pins) should be used on each sensor/wire harness combination. Mixing fastener types will produce inaccurate readings. Make sure all ring terminals have either screws or pins installed and placed in materials. Unattached ring terminals may produce unreliable MC readings. Sensor will report the highest MC reading.

Installation for drywall moisture readings:

To reduce damage in drywall, moisture readings are best taken with the push pins provided. Press the pins through the ring terminals into the drywall. To ensure good contact with the drywall material, avoid moving the pin

from side to side while pressing it in, and make sure that the metal head of the pin comes into good contact with the ring terminals. If a pin is pulled out of the drywall for some reason, it should be placed in a new location.

IMPORTANT:

Compensating for wire harness readings

When using two or more wire harnesses from the HygroTrac Extension Kit to evaluate multiple locations, the value displayed by the HygroTrac system will be slightly elevated (approximately 2%) compared to readings from individual sensors. Each inspection point is really a "resistance" measurement. When a sensor reads resistance across multiple locations, each location decreases the overall resistance of the circuit and results in a slightly elevated reading.

For this reason, when using the Extension Kit, a separate Dry Standard should be set that compensates for this elevated reading. It is recommended that the installer make this compensation using one or both of the following procedures:

1. Set a sensor with multiple inspection points in a known, comparable dry material and obtain a Dry Standard. Dry Standards are a reference point used to establish drying goals.
2. When a sensor with multiple inspection points approaches the drying goal (within 2 to 4 points), validate the material is completely dried using a handheld moisture meter.

PARTS LIST

- 24 Flat washers (3/16")
- 6 Nuts (#10-24 K-Lock Nut)
- 18 Aluminum-headed push pins (for drywall sensors)
- 6 Machine Screws (#10-24 x 2")
- 9 Wire Harness assemblies

Note: Screws and lock washers used for wood monitoring not provided.

Specifications are subject to change without notice.

FOR PARTS AND SERVICE CALL YOUR LOCAL DISTRIBUTOR or the Dri-Eaz Service Department at 800-932-3030 or 360-757-7776. www.dri-eaz.com

Figure 3

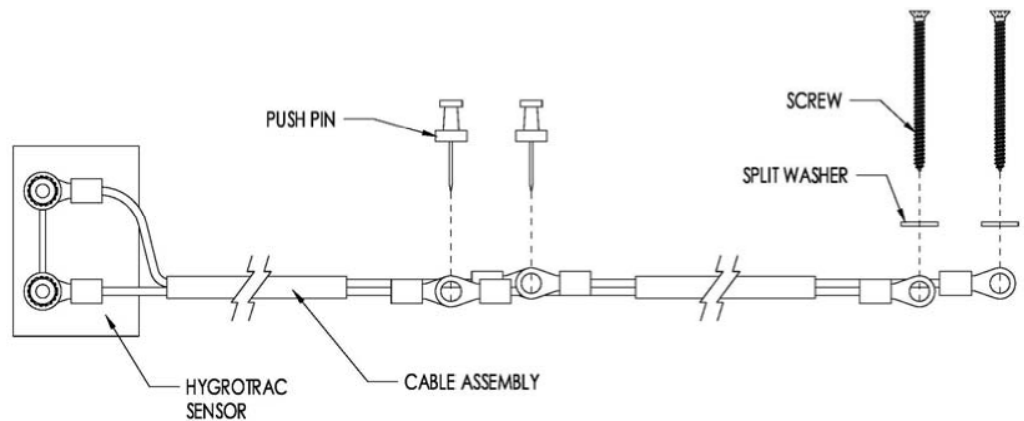

Note: Use only one type of fastener (either screws or pins) on each sensor/wire harness combination. Mixing fastener types will produce inaccurate readings.