



# INSTALLATION MANUAL

UH070CAV1  
UH105CAV  
UH140CAV

ENGLISH

ESPAÑOL

FRANÇAIS



**System Air Conditioner**  
(Cooling and Heating)

INVERTER

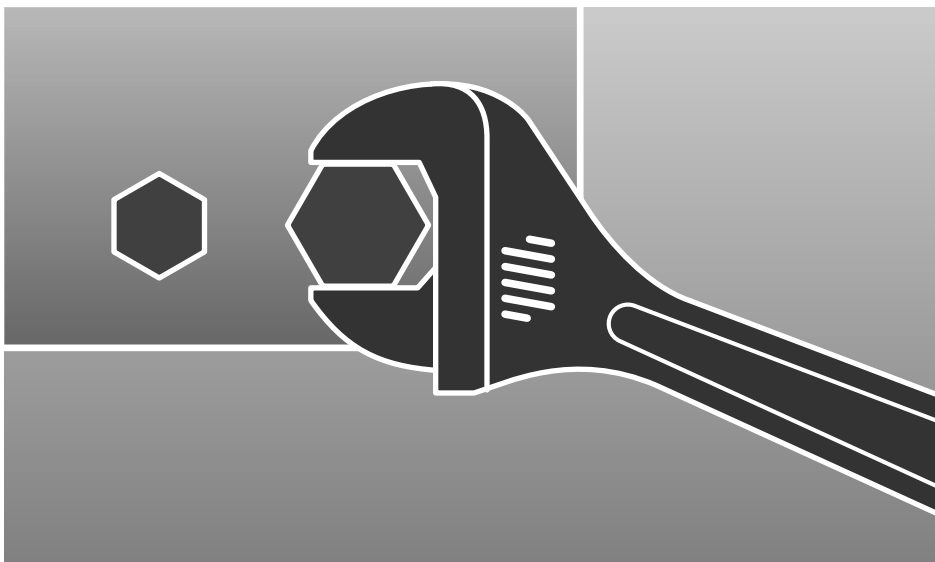

ESF DB98-29516A(3)

Air Marketing Group LLC

141 Kinderkamack Rd, Park Ridge, NJ 07656 Tel: 201-782-1782 Fax: 201-782-1783 Web: [www.amgair.com](http://www.amgair.com) Email: [info@amgair.com](mailto:info@amgair.com)



# Safety Precautions

*(Carefully follow the precautions listed below because they are essential to guarantee the safety of the equipment.)*



## WARNING

- Always disconnect the air conditioner from the power supply before servicing it or accessing its internal components.
- Verify that installation and testing operations are performed by qualified personnel.
- Verify that the air conditioner is not installed in an easily accessible area.

## GENERAL INFORMATION

- ◆ Carefully read the content of this manual before installing the air conditioner and store the manual in a safe place in order to be able to use it as reference after installation.
- ◆ For maximum safety, installers should always carefully read the following warnings.
- ◆ Store the operation and installation manual in a safe location and remember to hand it over to the new owner if the air conditioner is sold or transferred.
- ◆ This manual explains how to install an indoor unit with a split system with two SAMSUNG units. The use of other types of units with different control systems may damage the units and invalidate the warranty. The manufacturer shall not be responsible for damages arising from the use of non compliant units.
- ◆ The manufacturer shall not be responsible for damage originating from unauthorized changes or the improper connection of electric and requirements set forth in the "Operating limits" table, included in the manual, shall immediately invalidate the warranty.
- ◆ The air conditioner should be used only for the applications for which it has been designed: the indoor unit is not suitable to be installed in areas used for laundry.
- ◆ Do not use the units if damaged. If problems occur, switch the unit off and disconnect it from the power supply.
- ◆ In order to prevent electric shocks, fires or injuries, always stop the unit, disable the protection switch and contact SAMSUNG's technical support if the unit produces smoke, if the power cable is hot or damaged or if the unit is very noisy.
- ◆ Always remember to inspect the unit, electric connections, refrigerant tubes and protections regularly. These operations should be performed by qualified personnel only.
- ◆ The unit contains moving parts, which should always be kept out of the reach of children.
- ◆ Do not attempt to repair, move, alter or reinstall the unit. If performed by unauthorized personnel, these operations may cause electric shocks or fires.
- ◆ Do not place containers with liquids or other objects on the unit.
- ◆ All the materials used for the manufacture and packaging of the air conditioner are recyclable.
- ◆ The packing material and exhaust batteries of the remote control (optional) must be disposed of in accordance with current laws.
- ◆ The air conditioner contains a refrigerant that has to be disposed of as special waste. At the end of its life cycle, the air conditioner must be disposed of in authorized centers or returned to the retailer so that it can be disposed of correctly and safely.

## INSTALLING THE UNIT

**IMPORTANT:** When installing the unit, always remember to connect first the refrigerant tubes, then the electrical lines.  
Always disassemble the electric lines before the refrigerant tubes.

- ◆ Upon receipt, inspect the product to verify that it has not been damaged during transport. If the product appears damaged, DO NOT INSTALL it and immediately report the damage to the carrier or retailer (if the installer or the authorized technician has collected the material from the retailer.)
- ◆ After completing the installation, always carry out a functional test and provide the instructions on how to operate the air conditioner to the user.
- ◆ Do not use the air conditioner in environments with hazardous substances or close to equipment that release free flames to avoid the occurrence of fires, explosions or injuries.

## POWER SUPPLY LINE, FUSE OR CIRCUIT BREAKER

- ◆ Always make sure that the power supply is compliant with current safety standards. Always install the air conditioner in compliance with current local safety standards.
- ◆ Always verify that a suitable grounding connection is available.
- ◆ Verify that the voltage and frequency of the power supply comply with the specifications and that the installed power is sufficient to ensure the operation of any other domestic appliance connected to the same electric lines.
- ◆ Always verify that the cut-off and protection switches are suitably dimensioned.
- ◆ Verify that the air conditioner is connected to the power supply in accordance with the instructions provided in the wiring diagram included in the manual.
- ◆ Always verify that electric connections (cable entry, section of leads, protections...) are compliant with the electric specifications and with the instructions provided in the wiring scheme. Always verify that all connections comply with the standards applicable to the installation of air conditioners.

## Contents

---

■ Preparation for outdoor unit installation .....	4
■ Deciding on where to install the outdoor unit .....	6
■ Outdoor unit installation .....	9
■ Connecting the cable .....	10
■ Connecting the refrigerant pipe .....	13
■ Connecting up and removing air in the circuit .....	14
■ Cutting / Flaring the pipes .....	15
■ Performing leak tests .....	16
■ Connecting the drain hose to the outdoor unit .....	16
■ Insulation .....	16
■ Using stop valve .....	17
■ Adding refrigerant .....	18
■ Transmitter Installation (Optional) .....	20
■ Pump down Procedure .....	21
■ Checking correct grounding .....	22
■ Testing operations .....	23
■ Troubleshooting .....	24



# Preparation for outdoor unit installation

The air conditioner uses R410A refrigerant.

## Type A: UH105CAV/UH140CAV

### ■ Heat pump

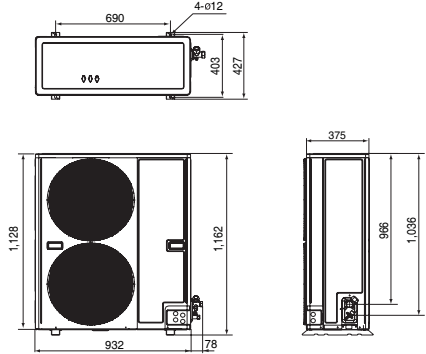
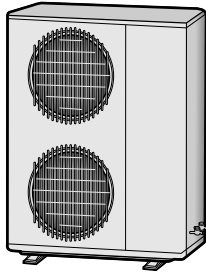

## Type B: UH070CAV1

### ■ Heat pump

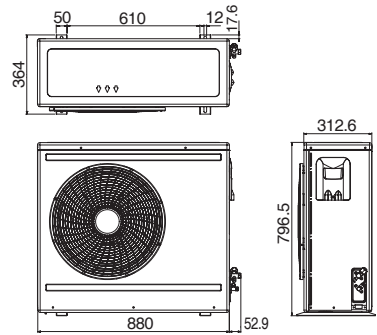
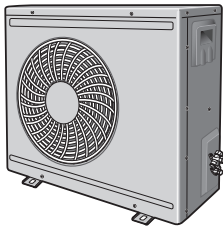

## ■ Moving the Outdoor Unit by Wire Rope

*Fasten the outdoor unit by two 8m or longer wire ropes as shown at the figure. To prevent from damage or scratches, insert a piece of cloth between the outdoor unit and rope, then move the unit.*

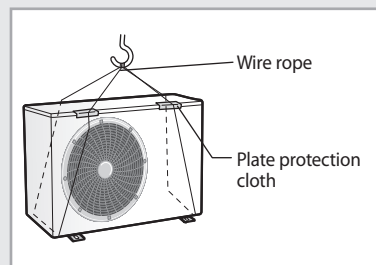

## Deciding on where to install the outdoor unit

### Outdoor Unit

- ◆ The outdoor unit must not be placed on its side or upside down, as the compressor lubrication oil will run into the cooling circuit and seriously damage the unit.
- ◆ Choose a location that is dry and sunny, but not exposed to direct sunlight or strong winds.
- ◆ Do not block any passageways or thoroughfares.
- ◆ Choose a location where the noise of the air conditioner when running and the discharged air do not disturb any neighbours.
- ◆ Choose a position that enables the pipes and cables to be easily connected to the indoor unit.
- ◆ Install the outdoor unit on a flat, stable surface that can support its weight and does not generate any unnecessary noise and vibration.
- ◆ Position the outdoor unit so that the air flow is directed towards the open area.
- ◆ Maintain sufficient clearance around the outdoor unit, especially from a radio, computer, stereo system, etc.

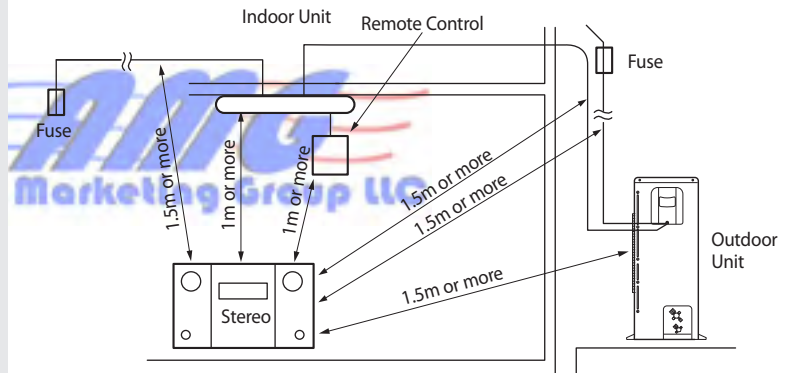

- ◆ If the outdoor unit is installed at a height, ensure that its base is firmly fixed in position.
- ◆ Make sure that the water dripping from the drain hose runs away correctly and safely.

#### CAUTION

- ◆ **You have just purchased a system air conditioner and it has been installed by your installation specialist.**
- ◆ **This device must be installed according to the national electrical rules.**
- ◆ **With an outdoor unit having net weight upper then 60kg, we suggest do not install it suspended on wall, but considering floor standing one.**

## Space Requirements for Outdoor Unit

### When installing 1 outdoor unit

Unit : mm

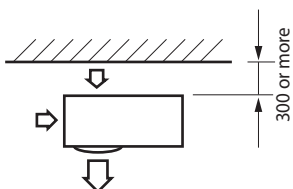

\* When the air outlet is opposite the wall

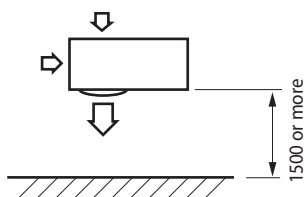

\* When the air outlet is towards the wall

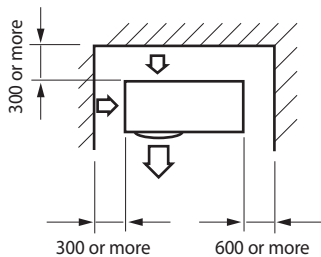

\* When 3 sides of the outdoor unit are blocked by the wall

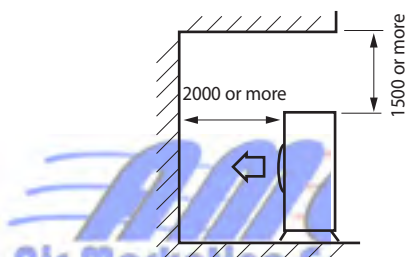

\* The upper part of the outdoor unit and the air outlet is towards the wall

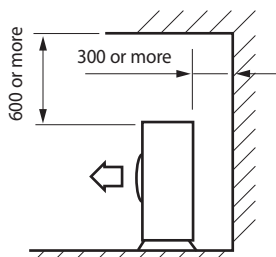

\* The upper part of the outdoor unit and the air outlet is opposite the wall

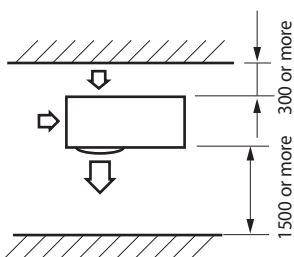

\* When front and rear side of the outdoor unit is towards the wall

# Deciding on where to install the outdoor unit (Continued)

## When installing more than 1 outdoor unit

Unit : mm

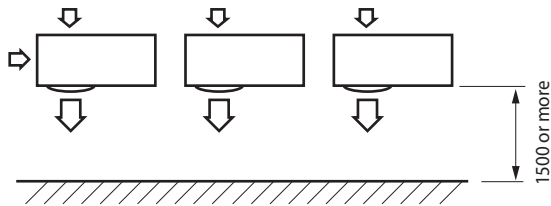

\* When the air outlet is towards the wall

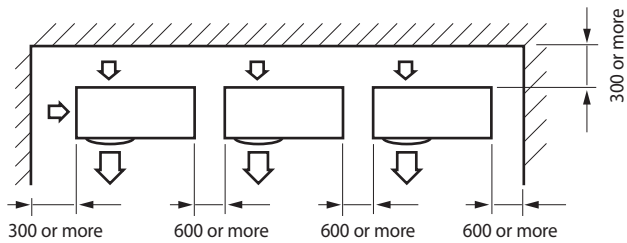

\* When 3 sides of the outdoor unit are blocked by the wall

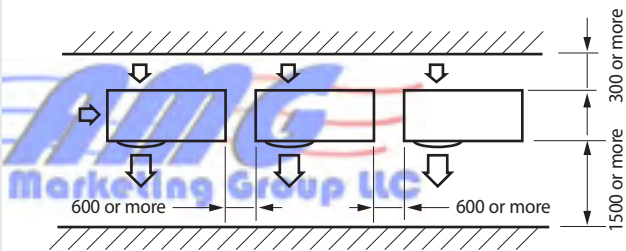

\* When front and rear side of the outdoor unit is towards the wall

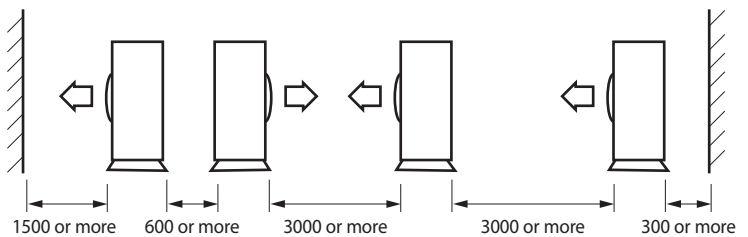

\* When front and rear side of the outdoor unit is towards the wall

### CAUTION

**Our units must be installed in compliance with the spaces indicated in the installation manual to ensure either accessibility from both sides or ability to perform routine maintenance and repairs. The units' components must be accessible and that can be disassembled in conditions of complete safety either for people or things.**



# Outdoor unit installation

**The outdoor unit must be installed on a rigid and stable base to avoid any increase in the noise level and vibration, particularly if the outdoor unit is to be installed in a location exposed to strong winds or at a height, the unit must be fixed to an appropriate support(wall or ground).**

Fix the outdoor unit with anchor bolts.

**Note** The anchor bolt must be 20mm or higher from the base surface.

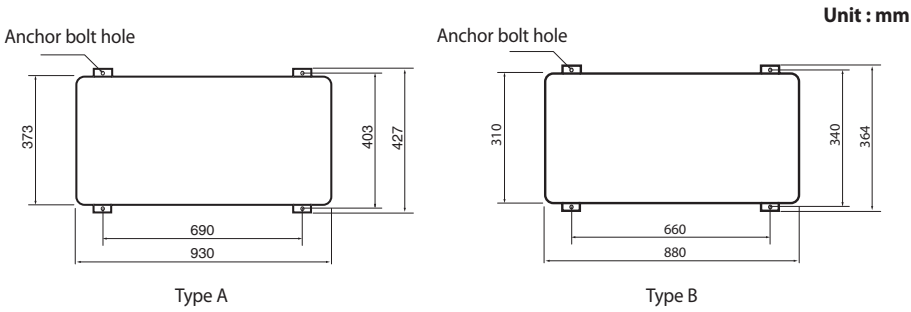

**CAUTION**

- ◆ **Make a drain outlet around the base for outdoor unit drainage.**
- ◆ **If the outdoor unit is installed on the roof, you have to check the ceiling strength and waterproof the unit.**

### Outdoor Unit Support

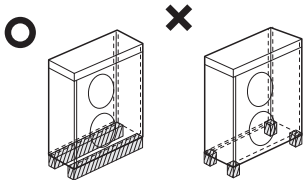

### OUTDOOR UNIT INSTALLED ON THE WALL BY RACK

- Ensure the wall will be able to suspend the weight of rack and outdoor unit;
- Install the rack close to the column as much as possible;
- Install proper grommet in order to reduce noise and residual vibration transferred by outdoor unit towards wall.

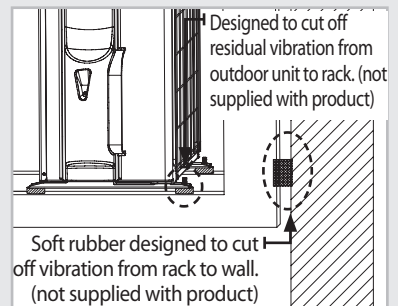
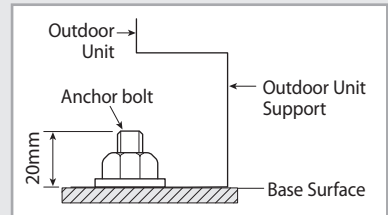

## Connecting the cable

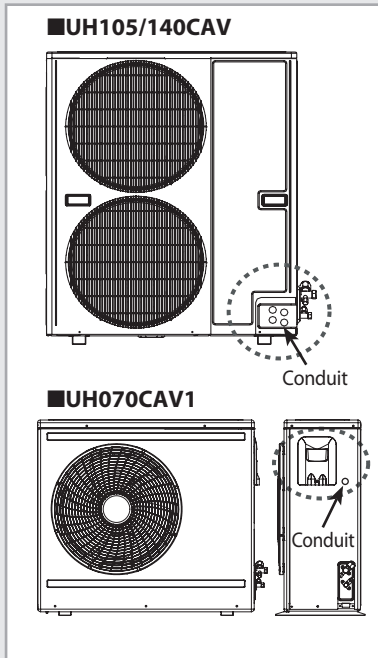

### Two electronic cables must be connected to the outdoor unit.

- ◆ The connection cord between indoor unit and outdoor unit.
- ◆ The power cable between outdoor unit and auxiliary circuit breaker.
- ◆ Be sure to run the power supply cable and the communication cable through electrical conduit as seen in the picture .
- ◆ Protect the power and communication cable using the protection tube individually.
- ◆ Make a knockout hole.
- ◆ After making a knockout hole ,apply rust resisting paint around the hole.
- ◆ Secure the cable tube to the outdoor knockout using the CD connector and bushing.

### CAUTION

- ◆ During the unit installation make first refrigerant connections and then electrical connections. If unit is uninstalled first disconnect electrical cables, then refrigerant connections.
- ◆ Connect the air conditioner to grounding system before performing the electrical connection.

## Example of Air Conditioner System

### When using ELB for 1 phase

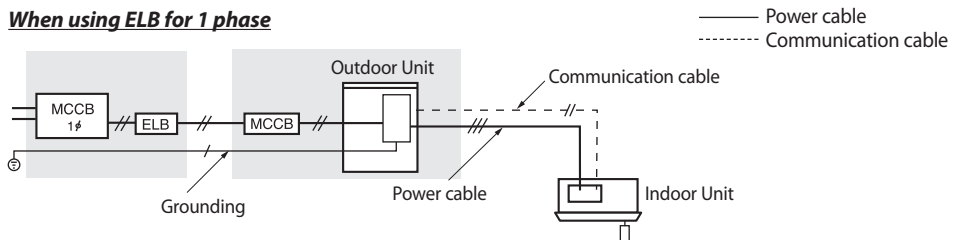

- \* If an outdoor unit is installed in a place in danger of an electric leak or submergence, you must install the ELB.

## Power Cable Specifications

Outdoor	Power supply	power cable	MAX. LENGTH	Type GL
		inch <sup>2</sup> (mm <sup>2</sup> ),wires	ft(m)	
UH070CAV1	1φ, 208-230V~/60Hz	0.007inch <sup>2</sup> (4mm <sup>2</sup> ), 2	<32.8 ft(10m)	30
UH105CAV		0.013inch <sup>2</sup> (4mm <sup>2</sup> ), 2		30
UH140CAV		0.019inch <sup>2</sup> (6mm <sup>2</sup> ), 2		40

- ◆ The power cable is not supplied with air conditioner.
- ◆ For power cable, use the grade H07RN-F or H05RN-F materials.

## Wiring Diagram of Power Cable

### When using ELB for 1 phase

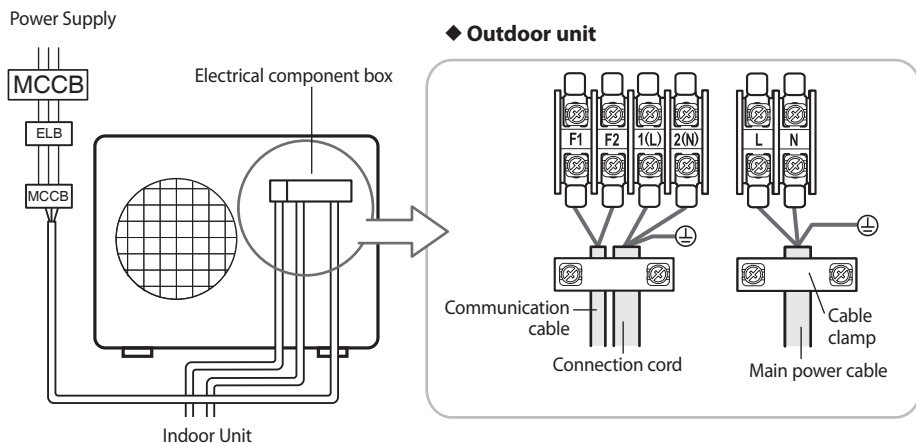



### CAUTION

- ◆ You should connect the power cable into the power cable terminal and fasten it with a clamp.
- ◆ The unbalanced power must be maintained within 2% of supply rating.  
- If the power is unbalanced greatly, it may shorten the life of the condenser.  
- If the unbalanced power is exceeded over 4% of supply rating, the indoor unit is protected, stopped and the error mode indicates.
- ◆ To protect the product from water and possible shock, you should keep the power cable and the connection cord of the indoor and outdoor units in the iron pipe.
- ◆ Ensure that main supply connection is made through a switch that disconnects all poles, with contact gap of a least 0.118 inch(3 mm).
- ◆ Must keep the cable in a protection tube.
- ◆ Keep distances of 1.968 inch(50 mm) or more between power cable and communication cable.

# Connecting the cable (Continued)

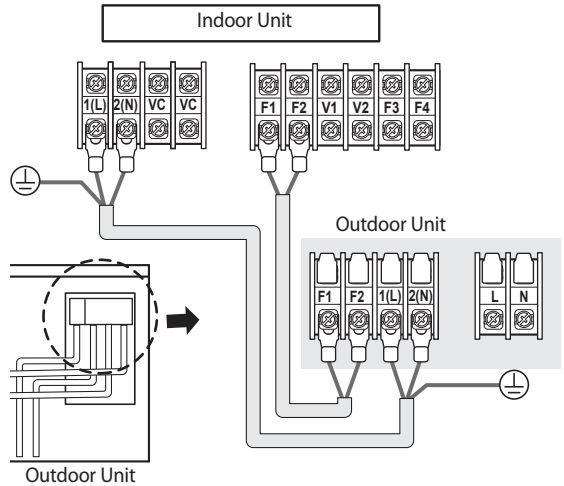
## Wiring Diagram of Connection Cord



*Note*  Ground wire for the indoor unit and outdoor unit connection cable must be clamped to a soft copper tin-plated eyelet terminal with M4 screw hole (NOT SUPPLIED WITH UNIT ACCESSORIES).

## Connecting the Power Terminal

- ◆ Connect the cables to the terminal board using the compressed ring terminal.
- ◆ Connect the rated cables only.
- ◆ Connect using a driver which is able to apply the rated torque to the screws.
- ◆ If the terminal is loose, fire may occur caused by arc.  
If the terminal is connected too firmly, the terminal may be damaged.

Tightening Torque (ft.lb (kgf · cm))		
M3	0.43(5.9)	1 phase, 208-230V~

# Connecting the refrigerant pipe

## Refrigerant Piping System

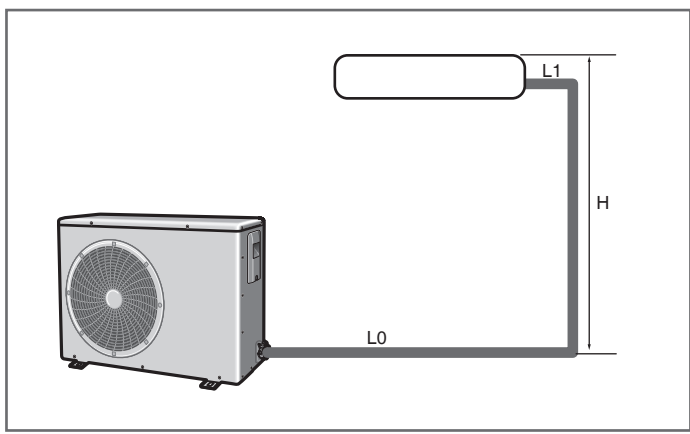

Refrigerant piping system table			Pipe length or height	
			UH070CAV1	UH105CAV UH140CAV
Max. allowable length	Actual pipe length	$L0 + H + L1$	164.04ft(50m) or less	246.06ft(75m) or less
Allowable height length	Actual pipe length	H	98.43ft(30m) or less	98.43ft(30m) or less



\* Minimum pipe length: equal or more than 9.84ft(3m).

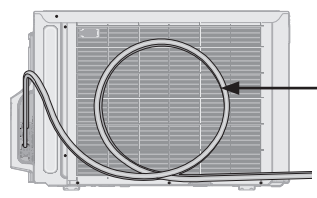

Make at least one round:  
It will reduce noise and vibration

\* The appearance of the unit may be different from the diagram depending on the model.

## Connecting up and removing air in the circuit

**The air in the indoor unit and in the pipe must be purged. If air remains in the refrigeration pipes, it will affect the compressor either reduce cooling/heating capacity or lead to a malfunction. Refrigerant for air purging is not charged in the outdoor unit. Use Vacuum Pump as shown at the right figure.**

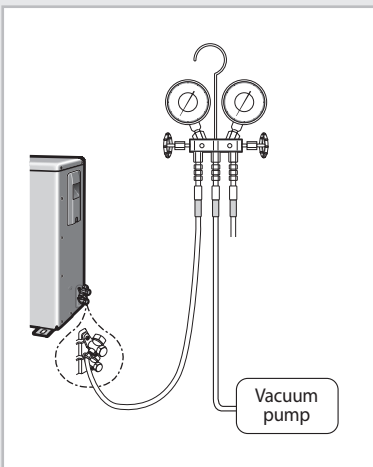
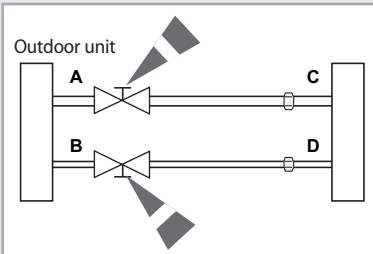

\* The designs and shape are subject to change according to the model.

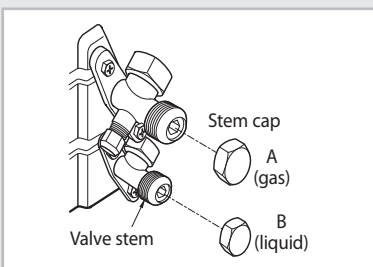

- 1 Connect each assembly pipe to the appropriate valve on the outdoor unit and tighten the flare nut.
- 2 Referring to the illustration opposite, tighten the flare nut on section B first manually and then with a torque wrench, applying the following torque.

Outer Diameter	Torque (ft.lb)
6.35 mm(1/4")	13.2
9.52 mm(3/8")	31.0
12.70 mm(1/2")	40.6
15.88 mm(5/8")	48.0
19.05 mm(3/4")	73.6

- 3 Connect the charging hose of low pressure side of manifold gauge to the packed valve having a service port as shown at the figure.

**CAUTION** Make the electrical connection and leave the system into "stand by mode". Do not turn on the system.

This is necessary to speed up vacuum operation (full OPEN position of Electronic Expansion Valve - EEV -).

- 4 Open the valve of the low pressure side of manifold gauge counterclockwise.
- 5 Purge the air from the system using vacuum pump for about 10 minutes.
  - ◆ Close the valve of the low pressure side of manifold gauge clockwise.
  - ◆ Make sure that pressure gauge shows -0.1MPa(-76cmHg) after about 10 minutes.  
This procedure is very important to avoid a gas leak.
  - ◆ Turn off the vacuum pump.
  - ◆ Remove the hose of the low pressure side of manifold gauge.

- 6 Set valve cork of both liquid side and gas side of packed valve to the open position.

- 7 Mount the valve stem nuts and the service port cap to the valve, and tighten them at the torque of 13.3ft.lb(183kgf.cm) with a torque wrench.

- 8 Check for gas leakage.
  - ◆ At this time, especially check for gas leakage from the 3-way valve's stem nuts(A port), and from the service port cap.

### CAUTION

- ◆ **Connect the indoor and outdoor units using pipes with flared connections (not supplied). For the lines, use insulated, unwelded, degreased and deoxidized copper pipe, (Cu DHP type to ISO 1337), suitable for operating pressures of at least 4200kPa and for a burst pressure of at least 20700kPa. Copper pipe for hydro-sanitary applications is completely unsuitable.**
- ◆ **For sizing and limits (height difference, line length, max. bends, refrigerant charge, etc.) see "Connecting refrigerant pipe section".**

# Cutting / Flaring the pipes

- 1 Make sure that you have the required tools available. (pipe cutter, reamer, flaring tool and pipe holder)
- 2 If you wish to shorten the pipes, cut it with a pipe cutter, taking care to ensure that the cut edge remains at a 90° angle with the side of the pipe. Refer to the illustrations below for examples of edges cut correctly and incorrectly.

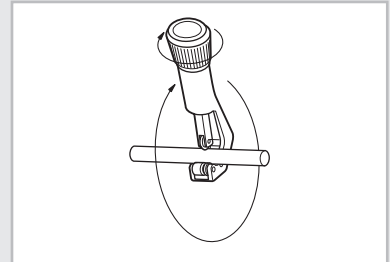
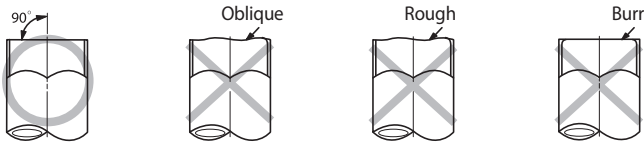

- 3 To prevent any gas from leaking out, remove all burrs at the cut edge of the pipe, using a reamer.
- 4 Slide a flare nut on to the pipe and modify the flare.

Outer Diameter (D)	Depth (A)
6.35 mm(1/4")	0.051 inch
9.52 mm(3/8")	0.070 inch
12.70 mm(1/2")	0.078 inch
15.88 mm(5/8")	0.086 inch
19.05 mm(3/4")	0.086 inch

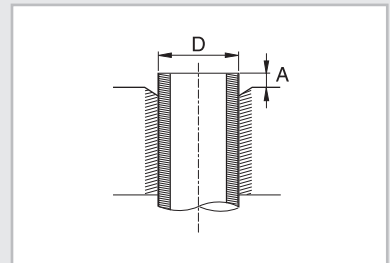

- 5 Check that the flaring is correct, referring to the illustrations below for examples of incorrect flaring.

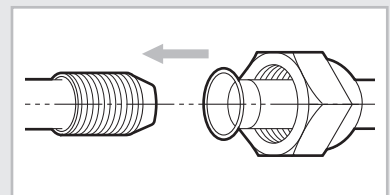
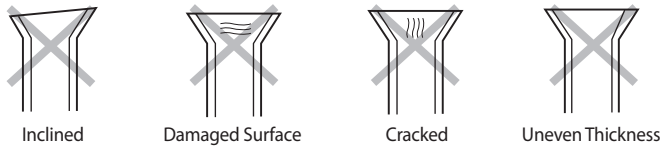

- 6 Align the pipes and tighten the flare nuts first manually and then with a torque wrench, applying the following torque.

Valve	Flare nut		Valve cap		Pressure port cap		Valve needle		Pressure port	
	Wrench (inch)	ft.lb	Wrench (inch)	ft.lb	Wrench (inch)	ft.lb	Wrench (inch)	ft.lb	Wrench (inch)	ft.lb
1/4"	0.67	13.2	0.91	14.8	0.7	11.8~13.3	Allen (hex.) 0.2	6.64	-	0.25
3/8"	0.87	31.0	0.91	14.8	0.7	11.8~13.3	Allen (hex.) 0.2	6.64	-	0.25
1/2"	1.02	40.6	1.14	29.5	0.7	11.8~13.3	Allen (hex.) 0.2	9.59	-	0.25
5/8"	1.14	48.0	1.14	29.5	0.7	11.8~13.3	Allen (hex.) 0.2	9.59	-	0.25
3/4"	1.42	73.6	1.5	29.5	0.7	11.8~13.3	Allen (hex.) 0.2	9.59	-	0.25

**CAUTION**

**In case of welding the pipe, you must weld with nitrogen gas blowing.**

## Performing leak tests

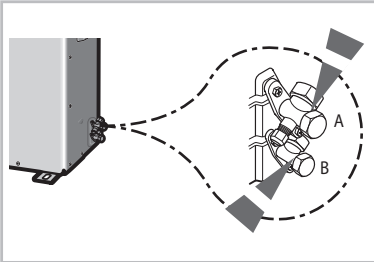

\* The designs and shape are subject to change according to the model.

### LEAK TEST WITH NITROGEN (before opening valves)

In order to detect basic refrigerant leaks, before recreating the vacuum and recirculating the R410A, it's responsible of installer to pressurize the whole system with nitrogen (using a cylinder with pressure reducer) at a pressure above 30 bar (gauge).

### LEAK TEST WITH R410A (after opening valves)

Before opening valves, discharge all the nitrogen into the system and create vacuum. After opening valves check leaks using a leak detector for refrigerant R410A.

Once you have completed all the connections, check for possible leaks using leak detector specifically designed for HFC refrigerants.

To check for gas leaks on the...

Then, using a leak detector, check the...

Outdoor unit

Valves on sections A and B.

## Connecting the drain hose to the outdoor unit

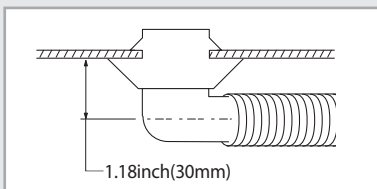
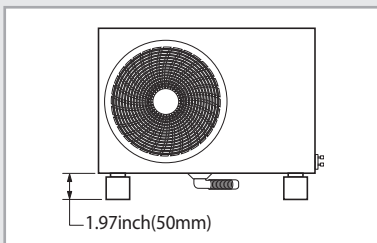

**When using the air conditioner in the heating mode, ice may accumulate. During de-icing (defrost operation), the condensed water must be drained off safely. Consequently, you must install a drain hose on the outdoor unit, following the instructions below.**

- 1 Make space more than 1.97inch(50mm) between the bottom of the outdoor unit and the ground for installation of the drain hose, as shown in figure.
- 2 Insert the drain plug into the hole on the underside of the outdoor unit.
- 3 Connect the drain hose to the drain plug.
- 4 Ensure that the drained water runs off correctly and safely.

## Insulation

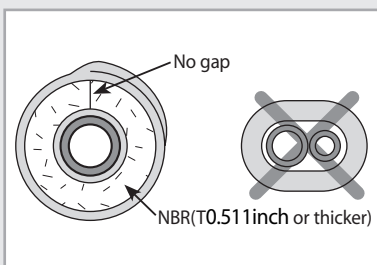

**Once you have checked that there are no leaks in the system, you can insulate the piping and hose.**

- 1 To avoid condensation problems, place an insulator around each refrigerant pipe.

### Note

- ◆ When insulate the pipe, be sure to overlap the insulation.
- ◆ You have to use more than 248°F(120°C) insulation(T0.511inch(13 mm) or thicker Acrylonitrile Butadien Rubber) for the gas refrigerant pipe.



## Using stop valve

### To Open the Stop Valve

1 Open the cap and turn the stop valve counterclockwise by using a hexagonal wrench.

2 Turn it until the axis is stopped.

*Note*

- ◆ Do not apply excessive force to the stop valve and always use special instruments. Otherwise, the stopping box can be damaged and the back sheet can leak.
- ◆ If the watertight sheet leaks, turn the axis back by half, tighten the stopping box, then check the leakage again. If there is no leakage any more, tighten the axis entirely.

3 Tighten the cap securely.

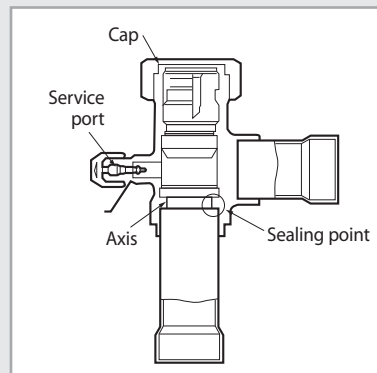

### To Close the Stop Valve

1 Remove the cap.

2 Turn the stop valve clockwise by using a hexagonal wrench.

3 Tighten the axis until the valve reached the sealing point.

4 Tighten the cap securely.

**CAUTION**

- ◆ **When you use the service port, always use a charging hose, too.**
- ◆ **Check the leakage of refrigerant gas after tightening the cap.**
- ◆ **Must use a spanner and wrench when you open/tighten the stop valve.**



# Adding refrigerant

**The outdoor unit is loaded with sufficient refrigerant for the standard piping. Thus, refrigerant must be added if the piping is lengthened. This operation can only be performed by a qualified refrigeration specialist. For quantity of adding refrigerant, refer to page 19.**

- 1 Check that the stop valve is closed entirely.
- 2 Charge the refrigerant through the service port of liquid stop valve.  
*Note* Do not charge the refrigerant through the gas side service port.
- 3 If you cannot charge the refrigerant according to the upper steps, following these:
  - 3-1 Open both liquid stop valve and gas stop valve.
  - 3-2 Operate the air conditioner by pressing the K2 key on the outdoor unit PCB.
  - 3-3 About 30 minutes later, charge the refrigerant through the service port of gas stop valve.

*Note* If necessary, refer to the pressure table classified by outdoor temperature.

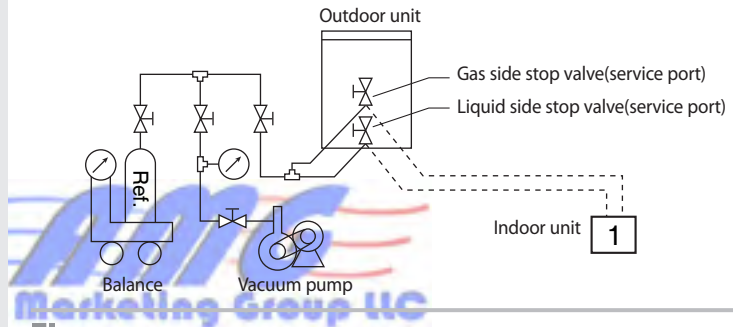

## Important information regulation regarding the refrigerant used

**This product contains fluorinated greenhouse gases covered by the Kyoto Protocol. Do not vent gases into the atmosphere.**

**CAUTION** Inform user if system contains 6.6lb(3kg) or more of fluorinated greenhouse gases. In this case, it has to be checked for leakage at least once every

12 months, according to regulation n°842/2006. This activity has to be covered by qualified personnel only.

In case situation above (6.6lb(3kg) or more of R-410A), installer (or recognised person which has responsibility for final check) has to provide a maintenance book, with all the information recorded according to REGULATION (EC) N° 842/2006 OF THE EUROPEAN PARLIAMENT AND OF THE COUNCIL of 17 May 2006 on certain fluorinated greenhouse gases.

Please fill in with indelible ink,

- ① the factory refrigerant charge of the product,
  - ② the additional refrigerant amount charged in the field and
  - ①+② the total refrigerant charge.
- on the refrigerant charge label supplied with the product.

*Note*

- a. Factory refrigerant charge of the product: see unit name plate
- b. Additional refrigerant amount charged in the field (Refer to the above information for the quantity of refrigerant replenishment.)
- c. Total refrigerant charge
- d. Refrigerant cylinder and manifold for charging

Refrigerant type	GWP value
R410A	1975

\* GWP=Global Warming Potential

Contains fluorinated greenhouse gases covered by the Kyoto Protocol.

① = (  $\frac{a}{b}$  ) lb      ①+② = (  $\frac{c}{c}$  ) lb

② = (  $\frac{b}{b}$  ) lb

## How to Calculate the Quantity of Adding Refrigerant

*If you have used more than "P", add "Q" of refrigerant for extra meter.*

*(For maximum piping length and height, refer to page 13)*

*The quantity of additional refrigerant is variable according to the installation situation. Thus, make sure the outdoor unit situation before adding refrigerant. This operation can only be performed by a qualified refrigeration specialist.*

Model	"Q"(R410A)	"P"
UH070CAV1	0.32oz/ft (30g/m)	16.4ft(5.0m)
UH105CAV	0.43oz/ft (40g/m)	24.6 ft(7.5m)
UH140CAV	0.43 oz/ft (40g/m)	24.6 ft(7.5m)

### i.e. 1 indoor unit

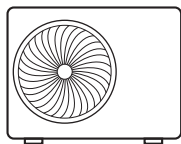

a

1

Piping length "a"	Additional charging amount	
	UH070CAV1	UH105CAV/UH140CAV
16.4ft(5.0m)	-	-
24.6 ft(7.5m)	2.65oz(75g)	-
31.17ft(9.5m)	4.76oz(135g)	2.82 oz(80g)

# Transmitter Installation (Optional)

## Accessories

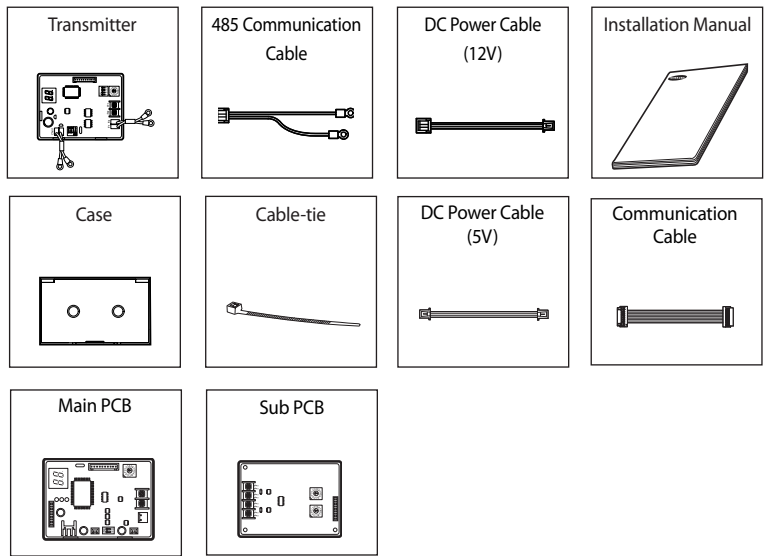

- 1 Fix the case at with bolts on the side of the control box in the outdoor unit. (See the picture)
- 2 Attach the transmitter PCB to the case in the control box in the outdoor unit, then connect the power and the communication cable between the transmitter and the outdoor unit; refer to the figure of page 20.
- 3 If you install a transmitter to an outdoor unit, every indoor unit which is connected to an outdoor unit can be controlled simultaneously.
- 4 Each outdoor unit connected to the same centralized controller has its own transmitter.

### ◆UH105/140CAV

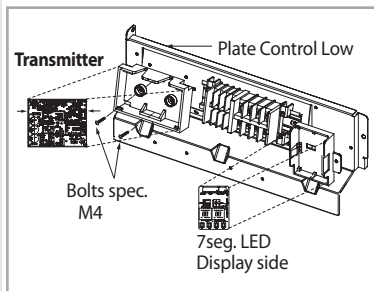

### ◆UH070CAV1

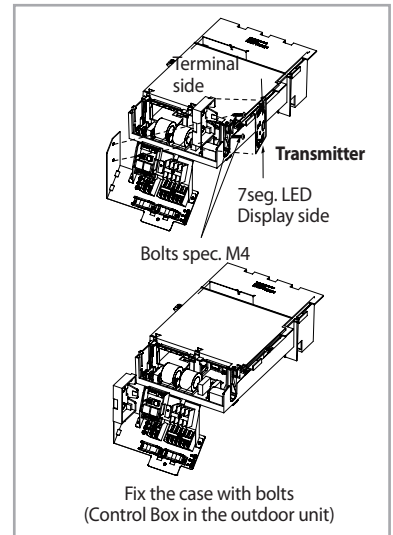

## Pump down Procedure

***Pump down will be carried out when an evaporator is replaced or when the unit is relocated in another area.***

- 1 Remove the cap from the low pressure side.
- 2 Turn the low pressure side valve clockwise to close and connect a pressure gauge (low pressure side) to the service valve, and open the valve again.
- 3 Set the unit to cool operation mode. (Check if the compressor is operating.)
- 4 Turn the high pressure side valve counter clockwise to close.
- 5 When the pressure gauge indicates "0" turn the low pressure side valve counter clockwise to close.
- 6 Stop operation of the air conditioner.
- 7 Close the each cap of valve.

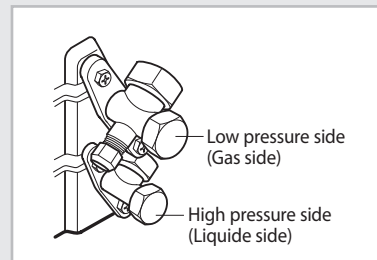

### *Notes*

#### ***Relocation of the air conditioner***

- ◆ Refer to this procedure when the unit is relocated.
- ◆ Carry out the pump down procedure (refer to the details of 'pump down').
- ◆ Remove the power cord.
- ◆ Disconnect the assembly cable from the indoor and outdoor units.
- ◆ Remove the flare nut connecting the indoor unit and the pipe.
- ◆ At this time, cover the pipe of the indoor unit and the other pipe using a cap or vinyl plug to avoid foreign material entering.
- ◆ Disconnect the pipe connected to the outdoor unit.  
At this time, cover the valve of the outdoor unit and the other pipe using a cap or vinyl plug to avoid foreign material entering.
- ◆ Make sure you do not bend the connection pipes in the middle and store together with the cables.
- ◆ Move the indoor and outdoor units to a new location.
- ◆ Remove the mounting plate for the indoor unit and move it to a new location.

## Checking correct grounding

**If the power distribution circuit does not have a grounding or the grounding does not comply with specifications, a grounding electrode must be installed. The corresponding accessories are not supplied with the air conditioner.**

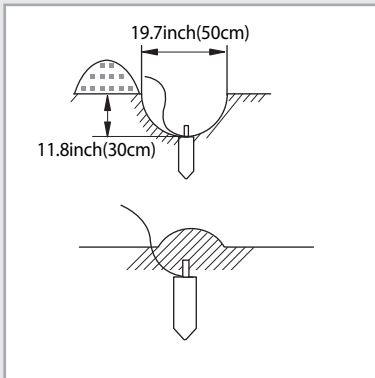
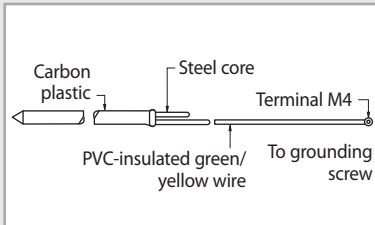

**1** Select a grounding electrode that complies with the specifications given in the illustration.

**2** Determine a suitable location for the grounding electrode:

- ◆ In damp hard soil rather than loose sandy or gravel soil that has a higher grounding resistance
- ◆ Away from underground structures or facilities, such as gas pipes, water pipes, telephone lines and underground cables
- ◆ At least two metres away from a lightning conductor grounding electrode and its cable

*Note* The grounding wire for the telephone line cannot be used to ground the air conditioner.

**3** Finish wrapping insulating tape around the rest of the pipes leading to the outdoor unit.

**4** Install a green/yellow coloured grounding wire:

- ◆ If the grounding wire is too short, connect an extension lead, in a mechanical way and wrapping it with insulating tape (do not bury the connection)
- ◆ Secure the grounding wire in position with staples

*Note* If the grounding electrode is installed in an area of heavy traffic, its wire must be connected securely.

**5** Carefully check the installation, by measuring the grounding resistance with a ground resistance tester. If the resistance is above required level, drive the electrode deeper into the ground or increase the number of grounding electrodes.

**6** Connect the grounding wire to the electrical component box inside of the outdoor unit.

# Testing operations

- 1 Check the power supply between the outdoor unit and the auxiliary circuit breaker.
  - ◆ Single phase power supply: L, N

---

- 2 Check the indoor unit.
  - 2-1 Check that you have connected the power and communication cables one mixed up or connected incorrectly, the PCB will be damaged.)
  - 2-2 Check the thermistor sensor, drain pump/hose, and display are connected correctly.

---

- 3 Press K1 & K2 on the outdoor unit PCB the system will follow this sequence:
  - ◆ K1 push one → start Heating test mode → K1 push two → test mode stop
  - ◆ K2 push one → start Cooling test mode → K2 push two → test mode stop

---

- 4 After 12 minutes of stationary condition check each indoor unit air treatment :
  - ◆ Cooling mode(indoor unit check) → Inlet air temp. - Outlet air temp. :  
From 50°F(10°C) to 53.6°F(12°C)
  - ◆ Heating mode(indoor unit check) → Outlet air temp. - Inlet air temp. :  
From 51.8°F(11°C) to 57.2°F(14°C)
  - ◆ In heating mode, the indoor fan motor can remain off to avoid cold air blown into conditioned space.

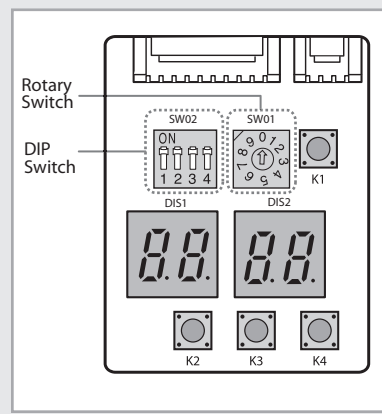

**Note**

- ◆ Rotary Switch must be adjusted to "0" position .
- ◆ DIP Switch must be adjusted to "ON" position .



## Settings of PCB Display of the Outdoor unit



Function	K1	K2	K3	K4
Number of press times				
1	Test operation at heating mode	Test operation at cooling mode	Reset	Displays Data
2	End	End	-	-

# Troubleshooting

The table below give indication about self diagnostic routine. Some of error code requires activities exclusively for Authorized Service Center.

## Outdoor unit

If an error occurs during the operation, it is displayed on the outdoor unit PCB.

Display	Content	Measure	Product operation status in case of error	Error type
			Outdoor unit compressor/ Outdoor unit fan	
<b>P01</b>	Indoor unit Communication Error	Check the communication line for indoor units, check the power supply of the communication phase (DC)	Operation Off	Communication Error
<b>P02</b>	Communication time-out error between indoor/outdoor unit 6-packet over error	Check the communication line for indoor units, check the power supply of the communication phase (DC)	Operation-off	Communication Error
<b>P21</b>	Indoor temperature sensor (open/short error)	Check the temp. sensor of the indoor unit room. Check the indoor PCB connector CN21(white)	Operation-off	Indoor Sensor Error
<b>P22</b>	Indoor unit Eva In sensor (open/short)	Check the indoor unit drainage pipe sensor.Check the indoor PCB connector CN21 (white)	Operation-off	Indoor Sensor Error
<b>P28</b>	Dismount of indoor unit Eva In sensor	Check the drainage pipe has been dismounted	Operation-off	Indoor Sensor Error
<b>P53</b>	Secondary detection of indoor floating switch	Check the indoor unit's float sensor- Check the indoor PCB connector CN51 (black)	Operation-off	Self Diagnosys Error
<b>201</b>	Indoor unit not connected	Check the indoor unit connection. Check the indoor unit option	Operation-off	Communication error
<b>202</b>	1min. Time out Comm. (Display Board : Onboard : Indoor ↔ Outdoor)	<ul style="list-style-type: none"> <li>• Check the indoor unit connection</li> <li>• Check the indoor unit option</li> </ul>	Operation-off	Communication error
<b>203</b>	Communication error between indoor/outdoor unit INV and Main Micom (1 min.)	Check the Main MICOM.Check the inverter MICOM	-	Communication error
<b>221</b>	Outdoor temperature sensor error	Outdoor temperature sensor error	Operation-off	Outdoor sensor error
<b>231</b>	Outdoor temperature sensor error	Check the connection status of the sensor Check the sensor location Check the resistance values of sensor	Operation-off	Outdoor sensor error
<b>251</b>	[inverter] Emission temperature sensor error	Check the connection status of the sensor Check the sensor location Check the resistance values of sensor	Operation-off	Outdoor sensor error
<b>416</b>	Excessive temperature emission	Not an error (discharge temp. control)	-	Outdoor unit protection control error
<b>425</b>	Power cable connection error	Check the status of power connection	Operation-off	Outdoor sensor error



Display	Content	Measure	Product operation status in case of error	Error type
			Outdoor unit compressor/ Outdoor unit fan	
460	Non-connection error of indoor and outdoor Communication wire (connected to the power terminal)	Check the status of power connection- Check the connection status of the communication line	Operation Off	Self Diagnosys Error
458	Outdoor fan 1 error	Check the input power connection status Check the connection status between the motor and PCB in outdoor unit. Check the fuse of indoor/outdoor units	Operation-off	Self Diagnosys Error
461	[inverter] Compressor operation error	Check the connection status of the compressor Check the resistance between different phases in compressor	Operation-off	Outdoor unit protection control error
462	Discharge current error/ PFC over-current error	Check the input power Check refrigerant is filled Check outdoor fan operates normally	Operation-off	Outdoor unit protection control error
464	[inverter] IPM over current error	Check refrigerant is filled; Check the connection status of compressor and if it operates normally; Check for any obstacles around indoor/outdoor units	Operation-off	Outdoor unit protection control error
467	[inverter] Compressor rotation error	Check the connection status of the compressor; Check the resistance between different phases in compressor	Operation-off	Outdoor unit protection control error
468	[inverter] Current sensor error	Check PCB operates normally	Operation-off	Communication error
469	[inverter] DC link voltage sensor error	Check the connection of input power. Check the status of RY21 and R2000 of Inverter PCB	Operation-off	Outdoor unit protection control error
478	[inverter] OTP error	Check PCB operates normally	Operation-off	Outdoor unit protection control error
475	Outdoor fan 2 error	Check the connection status of input power Check the connection status of motor and outdoor PCB Check the fuse of indoor/outdoor unit	Operation-off	Self Diagnosys Error
554	Gas leakage error	Check refrigerant is filled Check the indoor EVA sensor	Operation-off	Self Diagnosys Error
556	Inconsistent volume	Check the indoor unit's option code	Operation-off	Outdoor unit protection control error

