



# SYSTEM AIR CONDITIONER

MA DUCT SERIES

	INDOOR UNIT	OUTDOOR UNIT
Model :	AC018JNHDCH/AA	AC018JXADCH/AA
	AC024JNHDCH/AA	AC024JXADCH/AA
	AC030JNHDCH/AA	AC030JXADCH/AA
	AC036JNHDCH/AA	AC036JXADCH/AA
	AC042JNHDCH/AA	AC042JXADCH/AA
	AC048JNHDCH/AA	AC048JXADCH/AA

# SERVICE *Manual*

## AIR CONDITIONER



## CONTENTS

1. Precautions
2. Product Specifications
3. Disassembly and Reassembly
4. Troubleshooting
5. PCB Diagram
6. Wiring Diagram
7. Reference Sheet

# Contents

<b>1. Precautions</b> .....	<b>1-1</b>
1-1 Precautions for the Service .....	1-1
1-2 Precautions for the Static Electricity and PL .....	1-1
1-3 Precautions for the Safety .....	1-1
1-4 Others .....	1-1
<b>2. Product Specifications</b> .....	<b>2-1</b>
2-1 The Feature of Product .....	2-1
2-2 Product Specifications .....	2-2
2-3 Accessory .....	2-5
<b>3. Disassembly and Reassembly</b> .....	<b>3-1</b>
3-1 Indoor Unit .....	3-2
3-2 Outdoor Unit .....	3-10
<b>4. Trouble shooting</b> .....	<b>4-1</b>
4-1 Indoor Display Error and Check Method .....	4-1
4-2 Troubleshooting by symptoms .....	4-5
4-3 Setting Option Setup Method.....	4-13
4-4 Setting an indoor unit address and installation option .....	4-14
4-5 Items to be checked first .....	4-18
<b>5. PCB Diagram and Parts list</b> .....	<b>5-1</b>
5-1 Indoor Unit .....	5-1
5-2 Outdoor Unit .....	5-4
<b>6. Wiring Diagram</b> .....	<b>6-1</b>
6-1 Indoor Unit .....	6-1
6-2 Outdoor Unit .....	6-3
<b>7. Reference Sheet</b> .....	<b>7-1</b>
7-1 Refrigerating Cycle Diagram .....	7-1
7-2 Index for Model Name .....	7-2

---

# 1. Precautions

---

## 1-1 Precautions for the Service

---

- **Use the standard parts when replacing the electric parts.**
  - Confirm the model name, rated voltage, rated current of the electric parts.
- **Repair the disconnection of HARNESS securely when repairing the break down.**
  - If there is any connection error, it causes an abnormal noise and incorrect operation.
- **In case that you assemble or disassemble the products with laying it on the side, do work on the work cloth.**
  - If not, the exterior of products can be scratched.
- **Remove dust and foreign materials from harness, connection part, and inspection part thoroughly when repairing the break down.**
  - It protects the danger of fire such as tracking and short.
- **Tighten tightly the service valve of outdoor unit and the cap of charging valve with a monkey spanner.**
- **Check the assembly status of parts after repairing the break down.**
  - It should be same as the status before repairing.

## 1-2 Precautions for the Static Electricity and PL

---

- **As the PCB power terminal has a weakness for the static electricity, pay attention to it during the repair and measurement.**
  - Work with insulation gloves during the repair and measurement of PCB.
- **Check the distance between the product and the other electronic appliances such as TV, video, and audio. It should be over 2m.**
  - If not, it causes a bad picture quality or a noise.
- **Repairing the products by consumer should be strictly prohibited.**
  - There is a danger of electric shock or fire due to incorrect disassembly.

## 1-3 Precautions for the Safety

---

- **Do not pull any electric wires and do not touch an auxiliary power switch with a wet hand.**
  - There is a danger of electric shock or fire.
- **In case any wire or power plug has been damaged, replace it to eliminate any possible danger.**
- **Do not bend the power cord by force and do not put any heavy object on the power cord.**
  - There is a danger of electric shock or fire.
- **Do not use multi socket.**
  - There is a danger of electric shock or fire.
- **Ground the product if necessary.**
  - Be sure to ground the product if there is any danger of electric leakage due to water or moisture.
- **Be sure to turn off the auxiliary power switch or pull out the power plug during replacement or repair of electric parts.**
  - There is a danger of electric shock.
- **In case the product will not be in use for a long time, the battery of remote control should be kept separately.**
  - Leakage of inside fluid can cause break down of remote control.

## 1-4 Others

---

- **Never store or load the air conditioner upside down or sideways to prevent the damage to the compressor.**
- **Young children or infirm persons should be always supervised when they use the air conditioner.**
- **Max current is measured according to IEC standard for safety.**
- **Current is measured according to ISO standard for energy efficiency.**
- **When installing, make sure there is no leakage. When recovering the refrigerant, ground the compressor first before removing the connection pipe. If the refrigerant pipe is not properly connected and the compressor works with the service valve open, the pipe inhales the air and it makes the pressure inside of the refrigerant cycle abnormally high. It may cause explosion and injury.**
- **Pump Down Procedure (When removing the product)**
  - Turn on the air conditioner and select Cool mode to run the compressor for 3 minutes.
  - Release the valve caps on High and Low pressure side.
  - Use L wrench to close the valve on the high pressure side.
  - Approximately 2 minutes after, close the valve on the low pressure side.
  - Stop operation of the air conditioner.
  - Disconnect the pipes.

---

## 2. Product Specifications

---

### 2-1 The Feature of Product

---

#### **Built-in Duct Type**

After installed, the air conditioner can be harmonized with a room interior.

#### **High Performance & Energy Saving**

With the advanced BLDC inverter technology, it makes a room cool with highly energy saving and arises the efficiency of air conditioner.

#### **Long Piping (Length & Height)**

It can give the benefit to the installers and arises the reliability of the air conditioner.

#### **Long Ambient Operation (In Low Temperature)**

It can arise the reliability and the capacity of the air conditioner, especially operated in low temperature.

#### **Eco-friendly Product (Lead-Free, RoHS, WEEE)**







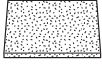
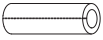
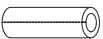
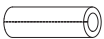

## 2-2 Product Specifications

ITEM			AC018JNHDCH AC018JXADCH	AC024JN4DCH AC024JXADCH
IMAGE	Indoor Unit			
	Outdoor Unit			
	Remote Controller			
Power	Product		1Φ, 208-230V/60Hz	1Φ, 208-230V/60Hz
Indoor	L x H x D	mm	1150*320*480	1150*320*480
Outdoor	L x H x D	mm	880*638*310	940*998*330
Indoor	Product		kg(Net)	43.0
Outdoor	Product		kg(Net)	45.0
Capacity	Cooling/Heating(ISO)		Btu/h	18,000/20,000
Power input	Cooling/Heating (ISO)		W	1,605/1,725
Operation current	Cooling/Heating (ISO)		A	7.4/8.0
Noise (Cooling/Heating)	Indoor unit	In case of strongest air blow	A	40
	Outdoor unit	In case of strongest air blow	A	58
Refrigerant (R410A)		g	1300(charged for 7.5m)	2100(charged for 7.5m)
Connecting Pipe		Liquid	mm	1/4"(6.35)
		Gas	mm	1/2"(12.7)
Additional Refrigerant (R410A)		g/m	10	10
Standard		m	7.5	7.5
Extension length(Total)		m	30	50
Extension length(Elevation)		m	20	30
Option Code		Product Option	01C0EC-1C8424-27343B-370005	01C0EC-1C747C-274750-370005
		Installation Option	020000-120000-200000-300000	020000-120000-200000-300000

ITEM			AC030JNHDCH AC030JXADCH	AC036JNHDCH AC036JXADCH	
IMAGE	Indoor Unit				
	Outdoor Unit				
	Remote Controller				
Power	Product		1Φ, 208-230V/60Hz	1Φ, 208-230V/60Hz	
Indoor	L x H x D	mm	1200*360*650	1200*360*650	
Outdoor	L x H x D	mm	940*998*330	940*1210*330	
Indoor	Product	kg(Net)	58.0	58.0	
Outdoor	Product	kg(Net)	70.0	88.0	
Capacity	Cooling/Heating(ISO)	Btu/h	30,000/32,000	36,000/40,000	
Power input	Cooling/Heating (ISO)	W	2,700/2,660	3,000/3,300	
Operation current	Cooling/Heating (ISO)	A	12.0/12.0	13.3/14.3	
Noise (Cooling/Heating)	Indoor unit	In case of strongest air blow	A	44	46
	Outdoor unit	In case of strongest air blow	A	60	60
Refrigerant (R410A)		g	2600(charged for 7.5m)	2800(charged for 7.5m)	
Connecting Pipe	Liquid	mm	3/8"(9.52)	3/8"(9.52)	
	Gas	mm	5/8"(15.88)	5/8"(15.88)	
Additional Refrigerant (R410A)		g/m	22	33	
Standard		m	7.5	7.5	
Extension length(Total)		m	50	75	
Extension length(Elevation)		m	30	30	
Option Code	Product Option		0100EC-1A55D4-275A64-370005	0100EC-1A5902-276470-370005	
	Installation Option		020000-120000-200000-300000	020000-120000-200000-300000	

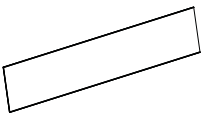
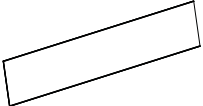
ITEM			AC042JNHDCH AC042JXADCH	AC048JNHDCH AC048JXADCH	
IMAGE	Indoor Unit				
	Outdoor Unit				
	Remote Controller				
Power	Product		1Φ, 208-230V/60Hz	1Φ, 208-230V/60Hz	
Indoor	L x H x D	mm	1200*360*650	1200*360*650	
Outdoor	L x H x D	mm	940*1210*330	940*1210*330	
Indoor	Product	kg(Net)	58.0	58.0	
Outdoor	Product	kg(Net)	88.0	88.0	
Capacity	Cooling/Heating(ISO)	Btu/h	42,000/47,000	48,000/53,000	
Power input	Cooling/Heating (ISO)	W	4,000/3,980	4,950/5,050	
Operation current	Cooling/Heating (ISO)	A	16.4/17.3	21.5/20.0	
Noise (Cooling/Heating)	Indoor unit	In case of strongest air blow	A	48	50
	Outdoor unit	In case of strongest air blow	A	62	62
Refrigerant (R410A)		g	2800(charged for 7.5m)	2800(charged for 7.5m)	
Connecting Pipe	Liquid	mm	3/8"(9.52)	3/8"(9.52)	
	Gas	mm	5/8"(15.88)	5/8"(15.88)	
Additional Refrigerant (R410A)		g/m	33	33	
Standard		m	7.5	7.5	
Extension length(Total)		m	75	75	
Extension length(Elevation)		m	30	30	
Option Code		Product Option	0100EC-1A194D-277D8C-370005	0100EC-1A1A81-278CA0-370005	
		Installation Option	020000-120000-200000-300000	020000-120000-200000-300000	



## 2-3 Accessory

Item	Descriptions	Code-No.	Q'TY	Remark
	Installation&Owner's Manual	DB68-05395A	1	Essential Offer (Indoor Unit)
	Insulation	DB62-04318S	1	
	Insu DRAIN HOSE	DB62-11028A	1/1/1	
	INSU HOSE D	DB62-11028E	1/1	
	INSU TUBE OUT	DB62-11028F	1/1	
	ASSY DRAIN HOSE JOINT	DB67-01191A	1	
	Ass'y Drain Hose Joint	DB90-06701A	1	
	GROMMET-HANGER	DB63-00237A	8	
	FILTER-PRE	DB63-01299B	1	
	FILTER-PRE	DB63-01299A	1	
	Cap Drain	DB63-10355C	3	Essential Offer (Outdoor Unit)
	Drain Plug	DB67-00806A	1	
	Rubber Leg	DB73-20134A	4	



### 3. Disassembly and Reassembly





#### Necessary Tools

Item	Remarks
+SCREW DRIVER	
Adjustable Wrench (8mm, 10mm, 13mm)	
M6, M8 Hex Wrench	

Disassemble should be worked in pairs.

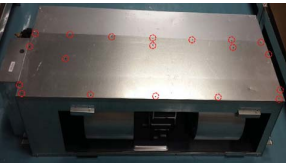

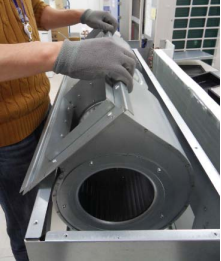
### 3-1 Indoor unit

#### AC018JNHDCH / AC024JNHDCH

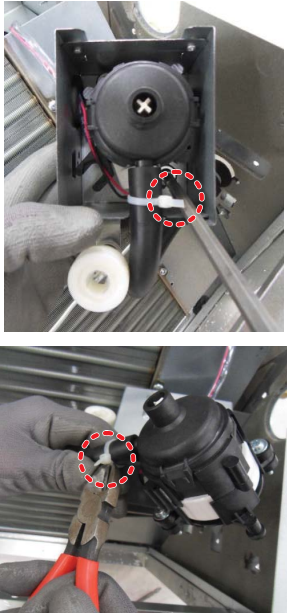
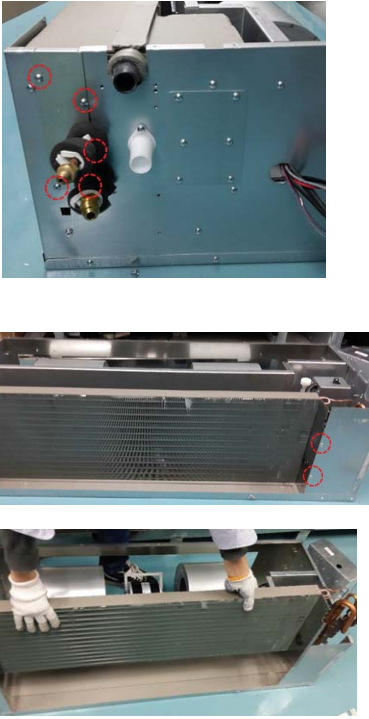

No	Parts	Procedure	Remark
1	Assy fan parts	<p>1)Disassemble the Cabinet-blower -Unscrew 19 screws</p> <p>2)Disassemble the Partition-front from Partition - Unscrew 8 screws</p> <p>3)Rotate the assy fan parts in CCW direction.</p> <p>4)Pull out the assy fan parts after hang at the edge of cabinet</p>	    



No	Parts	Procedure	Remark
2	Drain Pan	<p>1)Disassemble the cabinet-drain -Unscrew 7 screws</p> <p>2)Disassemble the Drain pan - Unscrew 4 screws.</p>	
3	Drain pump	<p>1)Disassemble the drain pump kit from the set. - Unscrew 2 screws</p> <p>2)Disassemble the drian pump case. - Unscrew 4 screws.</p>	

No	Parts	Procedure	Remark
3	Drain pump	3)Disassemble the drian pump. - Unscrew 2 screws and cabel tie.	
4	Evaporator	1)Disassemble the Cover-pipe -Unscrew 5 screws  2)Disassemble the Evaporator -Unscrew 4 screws	

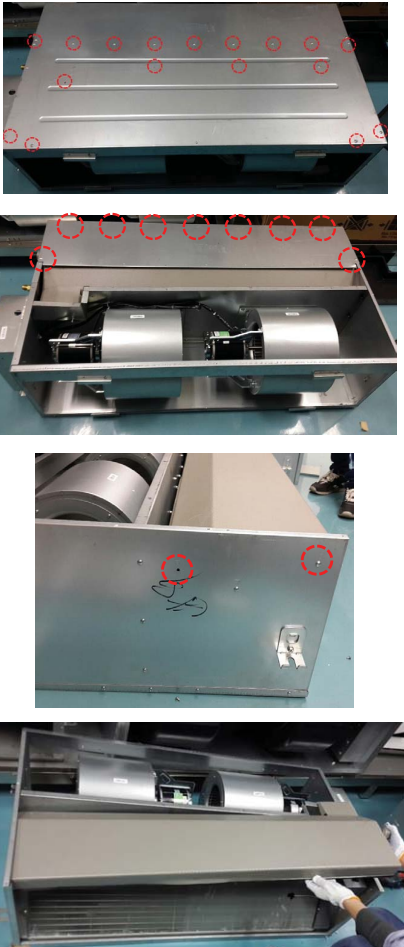
No	Parts	Procedure	Remark
5	Main PBA	<p>1)Disassemble the Case Control -Unscrew 3 screws</p> <p>2)Disassemble the Evaporator -Unscrew 4 screws</p>	  

AC030JNHDCH / AC036JNHDCH / AC042JNHDCH / AC048JNHDCH

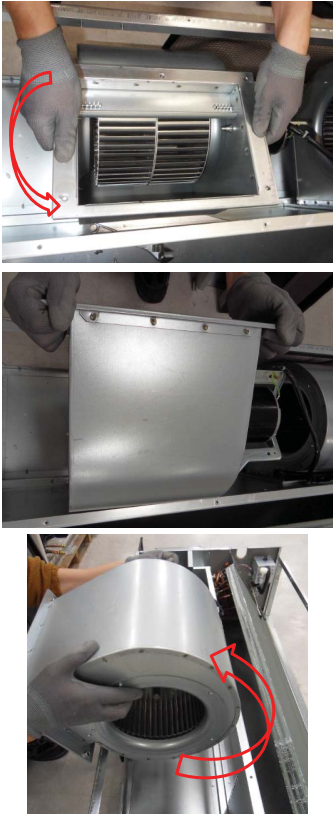
No	Parts	Procedure	Remark
1	Drain Pan	<p>1)Disassemble the cabinet-blower -Unscrew 17 screws</p> <p>2)Disassemble the cabinet-drain -Unscrew 9 screws</p> <p>3)Disassemble the drain pan -Unscrew 4 screws</p>	 <p>The Remark column contains four photographs illustrating the disassembly steps for the Drain Pan. The first photo shows the top of the cabinet with 17 screws circled in red. The second photo shows the cabinet with the blower assembly removed, and 9 screws on the inner panel circled in red. The third photo shows the drain pan being removed from the cabinet, with 4 screws circled in red. The fourth photo shows the drain pan being lifted out of the cabinet.</p>
2	Assy fan parts	<p>1)Disassemble the case blower from partition. - Unscrew 10 bolts by using wrench and driver.</p>	 <p>The Remark column contains three photographs showing the disassembly of the case blower. The first photo shows a person using a wrench to remove a bolt from the partition. The second photo shows a person using a driver to remove a bolt from the partition. The third photo shows the case blower being removed from the partition.</p>

No	Parts	Procedure	Remark
2	Assy fan parts	<p>2) Rotate the Assy fan parts in CCW direction</p> <p>3) Pull out the Assy fan parts after hang at the edge of cabinet</p>	
3	Drain pump	<p>1) Disassemble the drain pump kit from the set. - Unscrew 2 screws</p> <p>2) Disassemble the drain pump case. - Unscrew 4 screws.</p>	

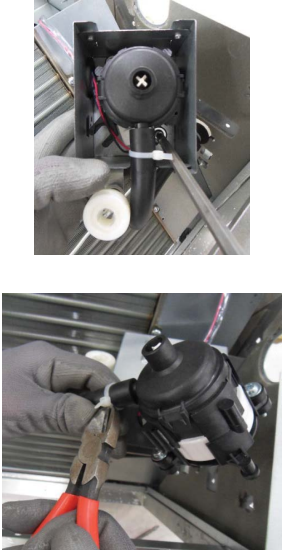
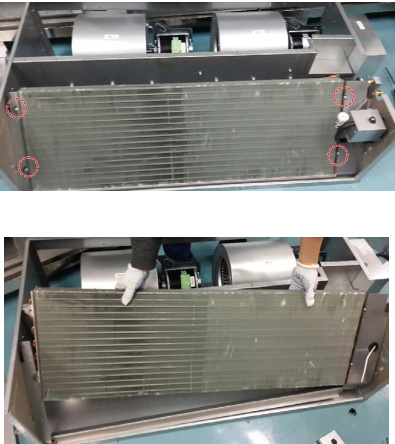

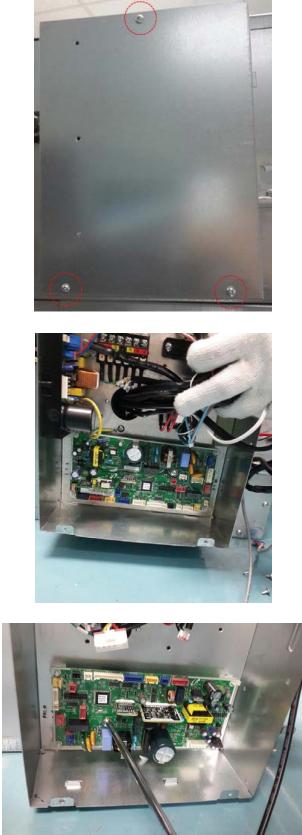

No	Parts	Procedure	Remark
3	Drain pump	3)Disassemble the drian pump. - Unscrew 2 screws and cabel tie.	
4	Evaporator	1)Disassemble the Evaporator - Unscrew 4 screws	





No	Parts	Procedure	Remark
5	Main PBA	<p>1)Disassemble the Case Control -Unscrew 3 screws</p> <p>2)Detach all connect cable</p> <p>3)Disassemble the PBA -Unscrew 1 screw</p>	

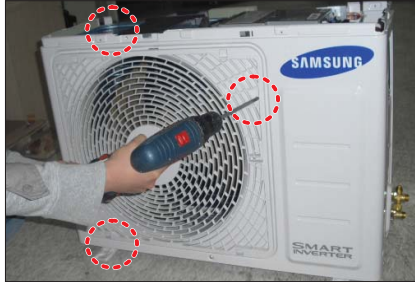

## 3-2 Outdoor Unit

### ■ AC018JXADCH

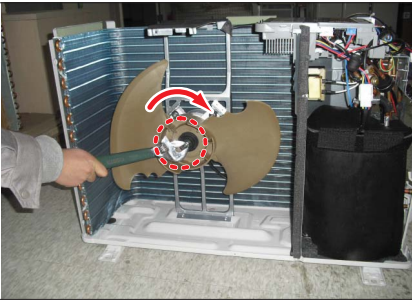
No	Parts	Procedure	Remark
1	common work	<p>1) loosen 1 pcs screw of cover control, and detach it.</p> <p>2) loosen 5 pcs screws on both right and left cabinet side edges and to detach the cover-top</p> <p>3) Loosen 7 screws fixed to disassemble cabi-front , and detach it.</p>	    



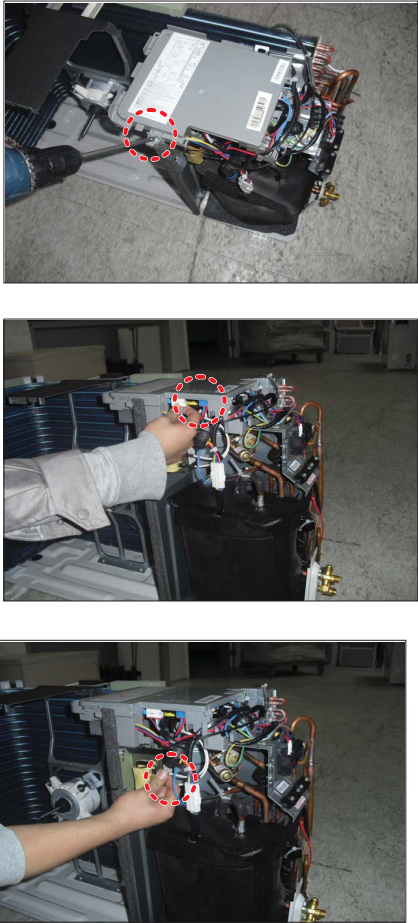

No	Parts	Procedure	Remark
	common work	<p>4) loosen 7 screws to disassemble the cabi-right ,and detach it.</p> <p>5) loosen 2 screws to disassemble steel-bar.</p> <p>6) loosen 3 screws to disassemble cabi-left.</p>	   



No	Parts	Procedure	Remark
2	fan&motor	<p>1) loosen 1 screw as indication and detached the fan.</p> <p>2) loosen 4 pcs motor screws and disconnect the wire between assy control out and motor.</p> <p>3) loosen 2 pcs bracket-motor screw and detach it.</p>	  

No	Parts	Procedure	Remark
3	assy control out	<ol style="list-style-type: none"> <li>1) loosen fixing 1 screw from cover-control</li> <li>2) detach several connections from assy control out, take out assy control out.</li> </ol>	
4	Heat exchanger	<ol style="list-style-type: none"> <li>1) Release the refrigerant at first</li> <li>2) Loosen fixing screw on both side.</li> <li>3) disassembly the pipes in both inlet and outlet with welding torch.</li> <li>4) detach the heat exchanger.</li> </ol>	



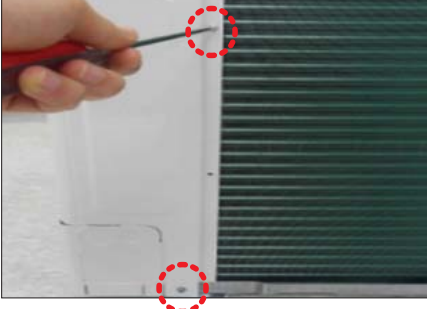
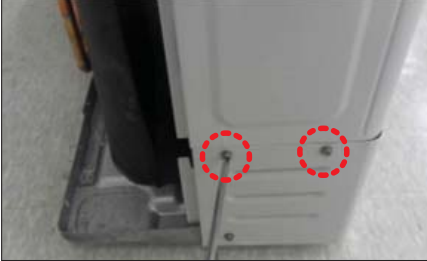

■ AC024JXADCH, AC030JXADCH

No	Parts	Procedure	Remark
1	Cabi Front RH	<p> You must turn off the Power before disassembly.</p> <p>1) Unscrew and remove two mounting screw in the Cabinet Front RH. (Use +Screw Driver)</p>	
2	Cabi Top	<p>1) Unscrew and remove 9 screws on each side of the Cabinet-Top. (Use +Screw Driver)</p>	
3	Cabi Install Front	<p>1) Unscrew and remove 1 screw in the Cabinet-Install Front. (Use +Screw Driver)</p>	

No	Parts	Procedure	Remark
4	Guard Cond	1) Pull the sensor from Guard Cond.  2) Unscrew and remove 4 screws in the Guard Cond. (Use +Screw Driver)	 
5	Cabi Back RH	1) Pull the sensor from Cabi Back RH.  2) Unscrew and remove 4 screws on each side of the Cabinet Back RH. (Use +Screw Driver)	  

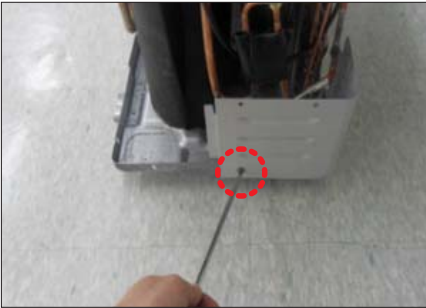
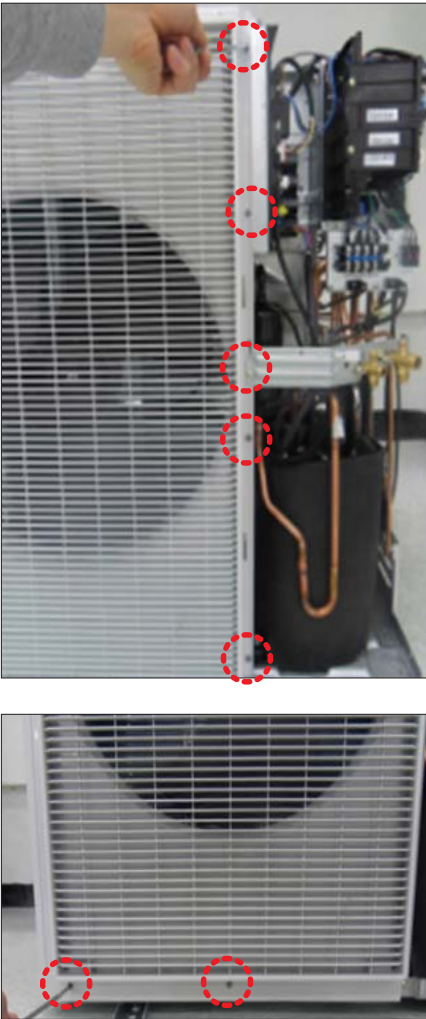

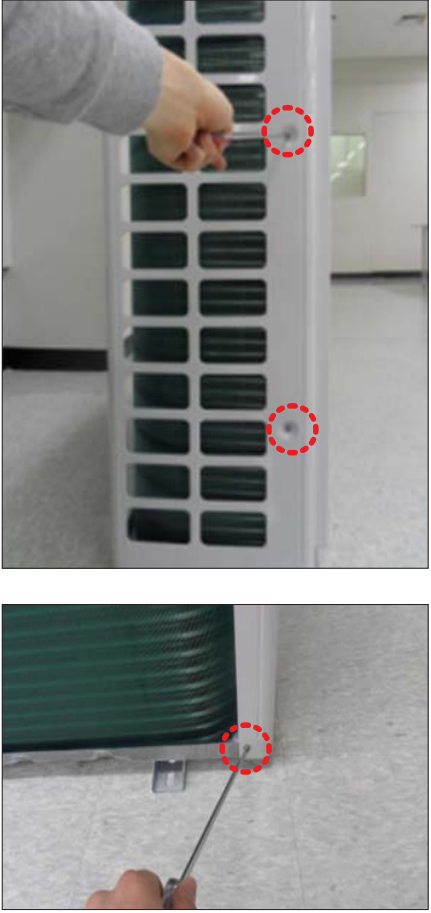

No	Parts	Procedure	Remark
6	Cabi Install Back	1) Unscrew and remove 1 screw in the Cabinet-Install Back. (Use +Screw Driver)	
7	Cabi Front LF	1) Unscrew and remove 10 screws in the Cabinet-Front LF. (Use +Screw Driver)	

No	Parts	Procedure	Remark
			
8	Fan	1) Turn 2 mounting nuts as shown in the picture and remove it. (Use Adjustable Wrench)	

No	Parts	Procedure	Remark
9	Motor	<ol style="list-style-type: none"> <li>1) Separate the Fan Propeller.</li> <li>2) Unscrew and remove the 8 Motor mounting screws. (Use +Screw Driver)</li>   <li>3) Disconnect the Motor wire From Ass'y Control Out.</li> </ol>	 
10	Bracket Motor	<ol style="list-style-type: none"> <li>1) Unscrew and remove 2 mounting screws in Bracket Motor. (Use +Screw Driver)</li> </ol>	



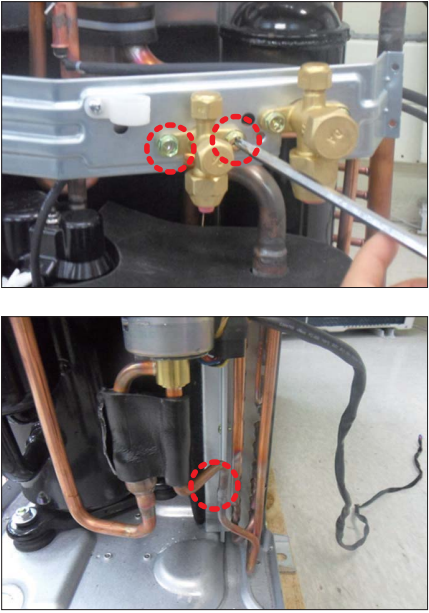



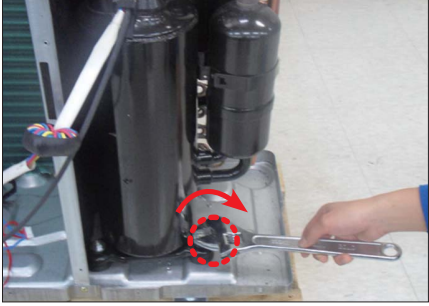
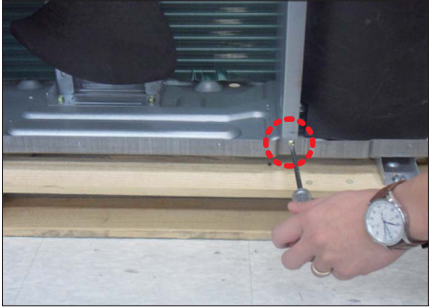
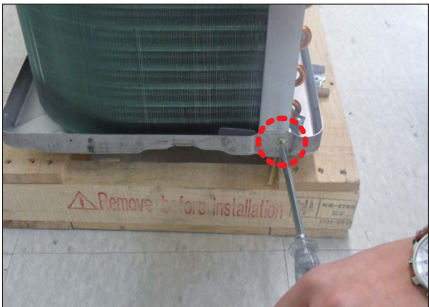
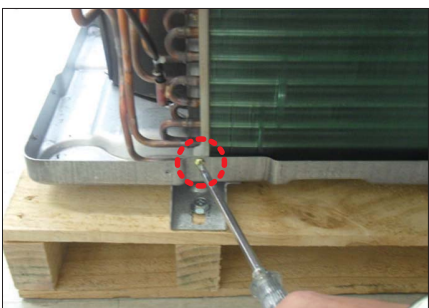

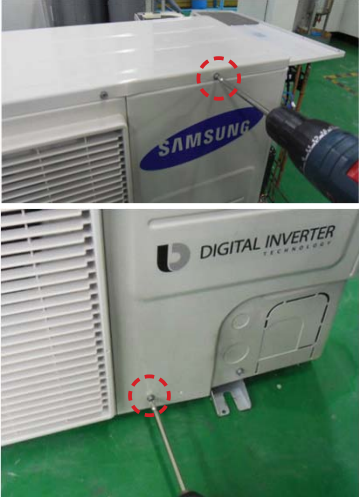

No	Parts	Procedure	Remark
13	Assy EEV Valve	<p>1) Unscrew and remove 2 mounting screws in Service Valve. (Use +Screw Driver)</p> <p>2) Separate the pipe from the Entrance/Exit using a welder.</p>	
14	Compressor	<p>1) Unscrew and remove 1 mounting nut in Cover Terminal. (Use Adjustable Wrench)</p> <p>2) Separate the Compressor Felt Sound.</p>	

No	Parts	Procedure	Remark
		<p>3) As shown in the picture, unscrew and remove 3 mounting screws from the bottom. (Use Adjustable Wrench)</p>	
15	Cond Out	<p>1) Unscrew and remove 3 screws on each side of the Assy Cond Out. (Use +Screw Driver)</p> <p>2) Separate the Compressor Felt Sound.</p>	  



■ AC036JXADCH, AC042JXADCH, AC048JXADCH

No	Parts	Procedure	Remark
1	Cabi Front RH	<p><b>⚠ You must turn off the Power before disassembly.</b></p> <p>1) Unscrew and remove two mounting screw in the Cabinet Front RH. (Use +Screw Driver)</p>	
2	Cabi Top	<p>1) Unscrew and remove 9 screws on each side of the Cabinet-Top. (Use +Screw Driver)</p>	
3	Cabi Install Front	<p>1) Unscrew and remove 1 screw in the Cabinet-Install Front. (Use +Screw Driver)</p>	
4	Guard Cond	<p>1) Pull the sensor from Guard Cond.</p> <p>2) Unscrew and remove 4 screws in the Guard Cond. (Use +Screw Driver)</p>	

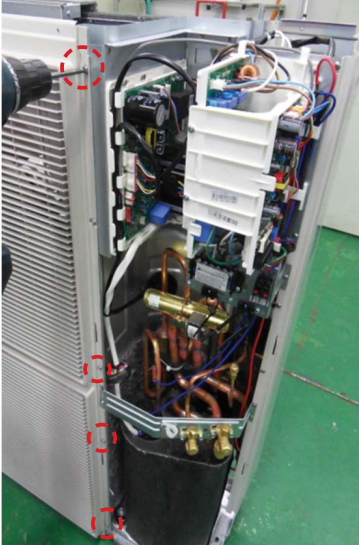
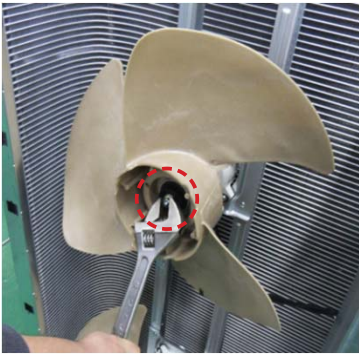

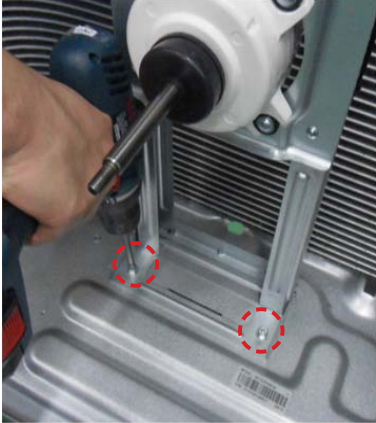
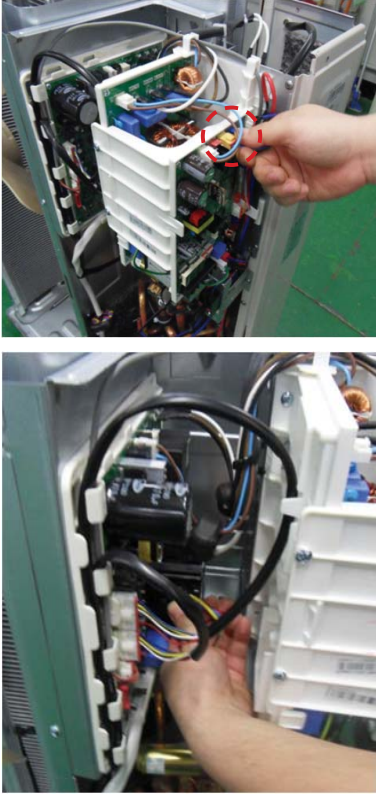
No	Parts	Procedure	Remark
5	Cabi Back RH	1) Pull the sensor from Cabi Back RH. 2) Unscrew and remove 4 screws on each side of the Cabinet Back RH. (Use +Screw Driver)	
6	Cabi Install Back	1) Unscrew and remove 1 screw in the Cabinet-Install Back. (Use +Screw Driver)	
7	Cabi Front LF	1) Unscrew and remove 10 screws in the Cabinet-Front LF. (Use +Screw Driver)	
8	Fan	1) Turn 2 mounting nuts as shown in the picture and remove it. (Use Adjustable Wrench)	

No	Parts	Procedure	Remark
9	Motor	1) Separate the Fan Propeller. 2) Unscrew and remove the 8 Motor mounting screws. (Use +Screw Driver) 3) Disconnect the Motor wire From Ass'y Control Out.	
10	Bracket Motor	1) Unscrew and remove 2 mounting screws in Bracket Motor. (Use +Screw Driver)	
11	Control Out	1) Disconnect 4 Connectors From Ass'y Control Out. 2) Unscrew and remove 1 mounting screw in Control Out. (Use +Screw Driver) 3) Separate Ass'y Control Out.	

No	Parts	Procedure	Remark
12	Assy 4way Valve	<p>1) Purge the Coolant first.</p> <p>2) Unscrew and remove 2 mounting screws in Service Valve. (Use +Screw Driver)</p> <p>3) Separate the pipe from the Entrance/Exit using a welder.</p> <p><b>⚠ When removing the compressor, Heat Exchanger, and Pipe, purge the Coolant inside the Compressor completely and remove the pipe with a welding flame.</b></p>	
13	Assy EEV Valve	<p>1) Unscrew and remove 2 mounting screws in Service Valve. (Use +Screw Driver)</p> <p>2) Separate the pipe from the Entrance/Exit using a welder.</p>	

## 4. Troubleshooting

















### 4-1 Indoor Display Error and Check Method

#### Error detection and reoperation

If error occurs during the operation, badness is indicated by LED flickering and all operation is stopped except LED.  
When reoperating by remote control and switch determine the error mode after normal operation.

#### 4-1-1 Indoor unit LED lamp display at error detecting

























##### LED Display on the receiver & display unit

Abnormal conditions	Indicators					Remarks
	Concealed Type					
	Green	Red				
	Standard Type					
						
Power reset		X	X	X	X	
Error of temperature sensor in the indoor unit (Open/Short)	X	X		X	X	
Error of heat exchanger sensor in the indoor unit		X		X	X	
Error of the outdoor temperature sensor Error of the condensor temperature sensor Error of the discharge temperature sensor		X	X		X	
1. No communication for 2 minutes between indoor units (Communication error for more than 2 minutes) 2. Indoor unit receiving the communication error from outdoor unit 3. Outdoor unit tracking 3 minutes error 4. When sending the communication error from the outdoor unit, the mismatching of the communication numbers and installed numbers after completion of tracking. (Communication error for more than 2 minutes)	X	X			X	1. Indoor unit error (Display is unrelated with operation) 2. Outdoor unit error (Display is unrelated with operation)

● On    ● Flickering    X Off

◆ If you turn off the air conditioner when the LED is flickering, the LED is also turned off.

## LED Display on the receiver & display unit

Abnormal conditions	Indicators					Remarks
	Concealed Type					
	Green	Red				
	Standard Type					
						
Communication error between indoor units		X	X	X		
1. Error of electronic expansion valve close 2. Error of electronic expansion valve open 3. 2 <sup>nd</sup> detection of high temperature cond 4. 2 <sup>nd</sup> detection of high temperature discharge 5. Error of reverse phase 6. Compressor down due to 6 <sup>th</sup> detection of freezing	X	X				
Clogging of outdoor's service valve		X	X			
Detection of the float switch	X	X	X			
Error of setting option switches for optional accessories	X	X		X		
Error of EEPROM or OPTION SETTING						

● On    ● Flickering    X Off

◆ If you turn off the air conditioner when the LED is flickering, the LED is also turned off.

## Wired remote control

- ◆ If an error occurs,  is displayed on the wired remote control. If you would like to see an error code, press the Test button.

Display	Explanation
101	Indoor unit Communication Error
102	Indoor/Outdoor unit Communication Time Out Error 60 Packet Over data
203	Communication Error between Outdoor Main and Inverter Micom (Occurred after 1 minute detection in Main and Inverter)
128	Indoor Unit Eva in Sensor Separation
153	Indoor Float S/W 2 <sup>nd</sup> Detection
460	Outdoor unit - indoor unit communication wire miss connection (Connected to Power terminal)
554	Outdoor unit refrigerant Full leakage (Gas leak)
458	Outdoor Fan 1 Error
475	Outdoor Fan 2 Error
461	[Inverter] Compressor starting error
462	Primary Current Over Trip error
464	[Inverter] DC PEAK error(O.C)
467	[Inverter] Compressor Rotation error
468	[Inverter] Current Sensor error
469	[Inverter] DC LINK Sensor error
471	[Inverter] EEPROM Read/Write Error
474	[Inverter] Heatsink temperature over Error
556	Outdoor unit Capacity Setup option error
601	Communication error between Indoor unit and wired remote control
602	Communication error between Master and Slave wired remote control
606	COM1/COM2 Cross-installed error
EA	Error of setting option for wired remote control COM2
123	Error on EVA OUT sensor of indoor unit (Short or Open)
124	Error on Discharge sensor of indoor unit (Short or Open)
154	Indoor unit Fan Error
151	Open error of EEV in indoor unit(2nd)
152	Close error of EEV in indoor unit(2nd)
128	Close error of electronic expansion valve in indoor unit(2nd)
129	Breakaway of Indoor unit Evaporator_out Sensor
241	COND_MID or COND OUT Sensor of Outdoor Unit breakaway Error

Display	Explanation
554	Gas leak detected
559	Indoor Unit operating stop due to detect unknown error in Outdoor Unit
403	Compressor down due to freeze protection control
307	High Pressure SENSOR breakaway ERROR
306	Low Pressure SENSOR breakaway ERROR
428	COMP down by Compression Ratio control Error 1
413	Outdoor SUMP DOWN_1 Protection Control
410	COMP down due to Low PressureSensor Protection Control 1
880	MCU SOL Valve cooling/heating opening 1st at the same time
887	MCU SOL Valve cooling/heating opening 1st at the same time
807	Outdoor Unit Communication Error
802	Outdoor Unit -> communication error to Indoor Unit
202	System Down (All Indoor unit Short) due to Communication Error
808	Error due to repeated communication address
853	Error on float switch (2nd detection)
862	Outdoor unit EEPROM error
863	EEPROM OPTION SETTING ERROR
898	Error on thermal fuse of indoor unit (Open)

## 4-2 Troubleshooting by symptoms

### 4-2-1 Indoor temperature sensor (open/short)

Indoor unit display	X (Operation) X (Defrost) (Timer) X(Fan) X (Filter)
Wire remote controller display	E121
Symptom	Error of Room sensor in the indoor unit(Open/Short)
Failure	Short or leakage of the Room sensor

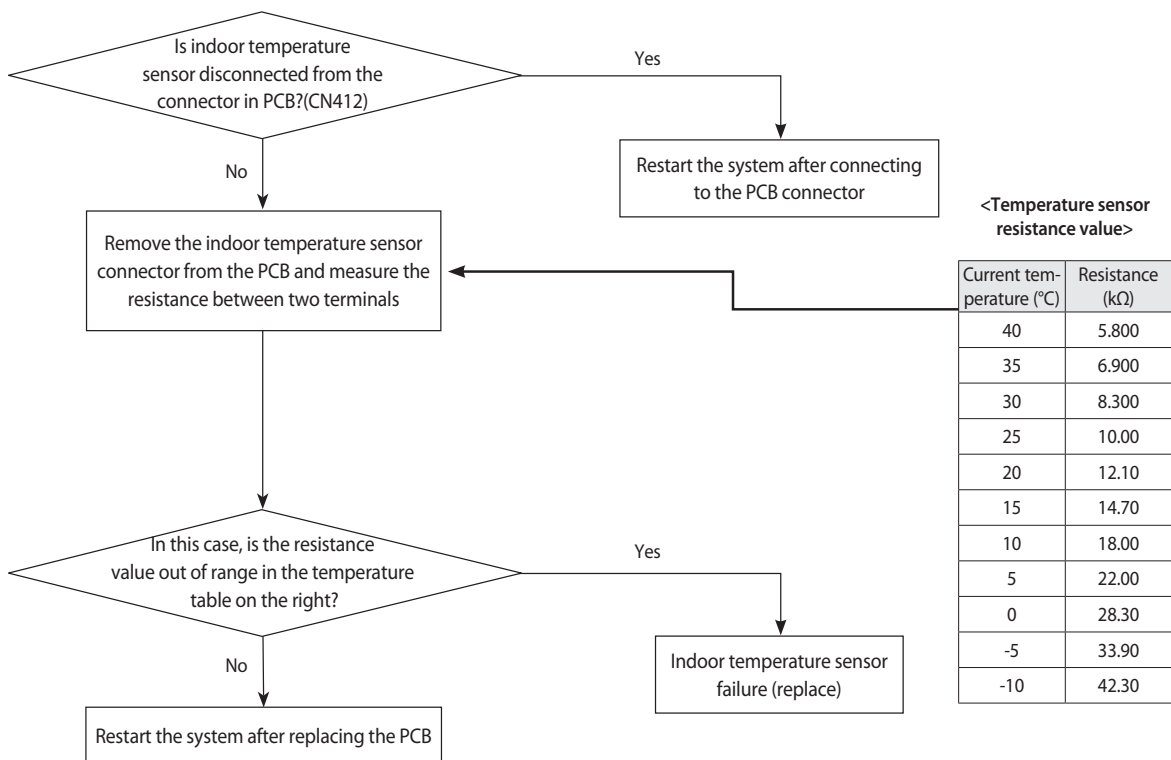



## 4-2-2 Eva in and out sensor (open/short)

Indoor unit display	● (Operation) X (Defrost) ● (Timer) X (Fan) X (Filter)
Wire remote controller display	E122
Symptom	Error of EVA-IN,EVA-OUT sensor in the indoor unit(Open/Short)
Failure	Short or leakage of the EVA sensor

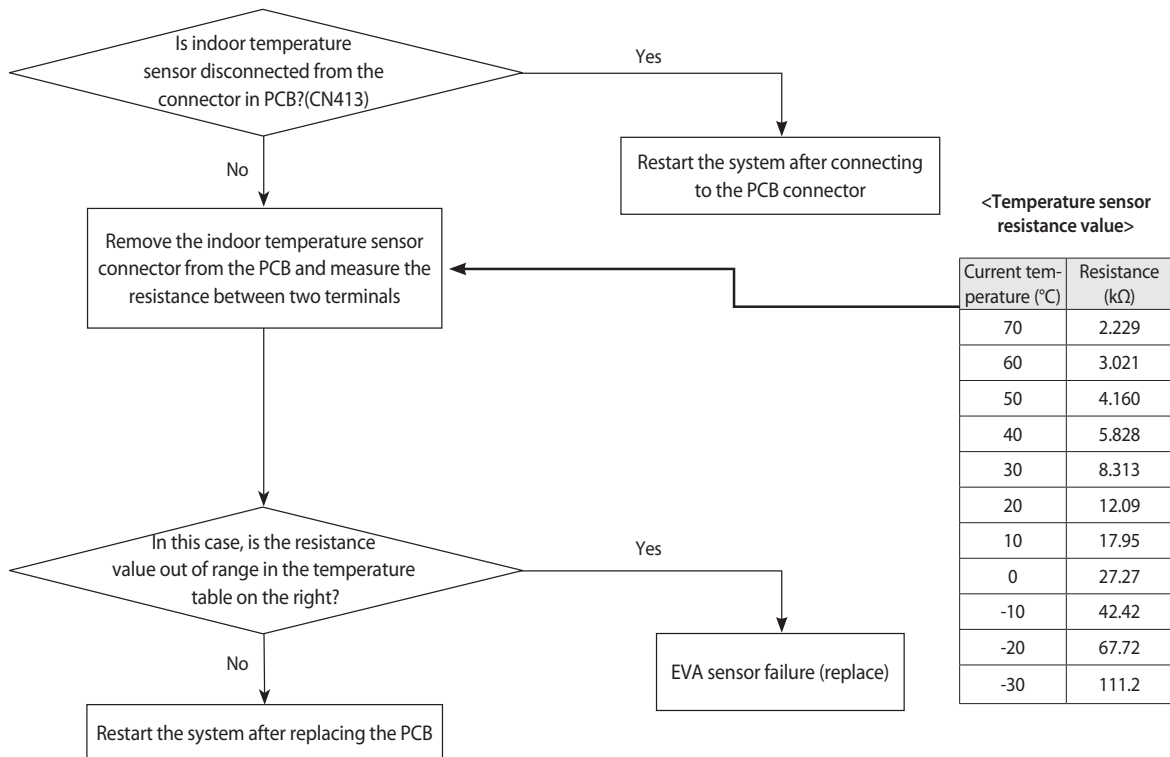

### 4-2-3 Fan error

Indoor unit display	X (Operation) X (Defrost) X(Timer) ● (Fan) X (Filter)
Wire remote controller display	E154
Symptom	Error of Fan motor in the indoor unit
Failure	Fan error

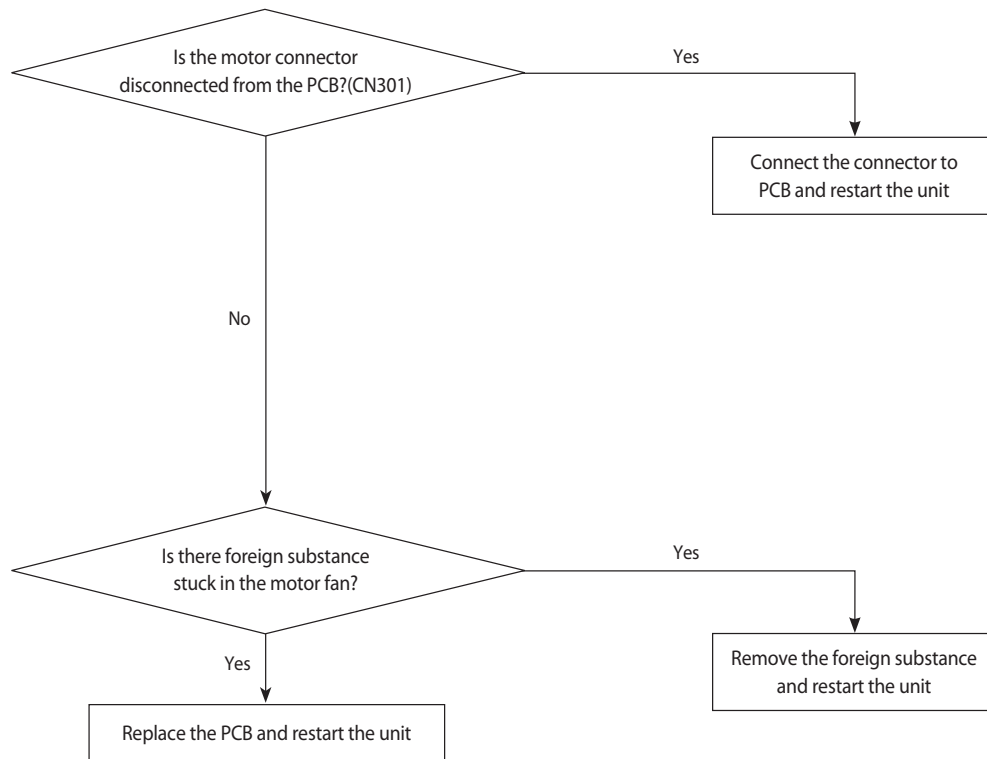

#### 4-2-4 Terminal Block's Terminal Fuse(Open)

Indoor unit display	X (Operation) X (Defrost) ● (Timer) ● (Fan) ● (Filter)
Wire remote controller display	E198
Symptom	Error of Terminal Block's Terminal Fuse(Open)
Failure	Fuse open

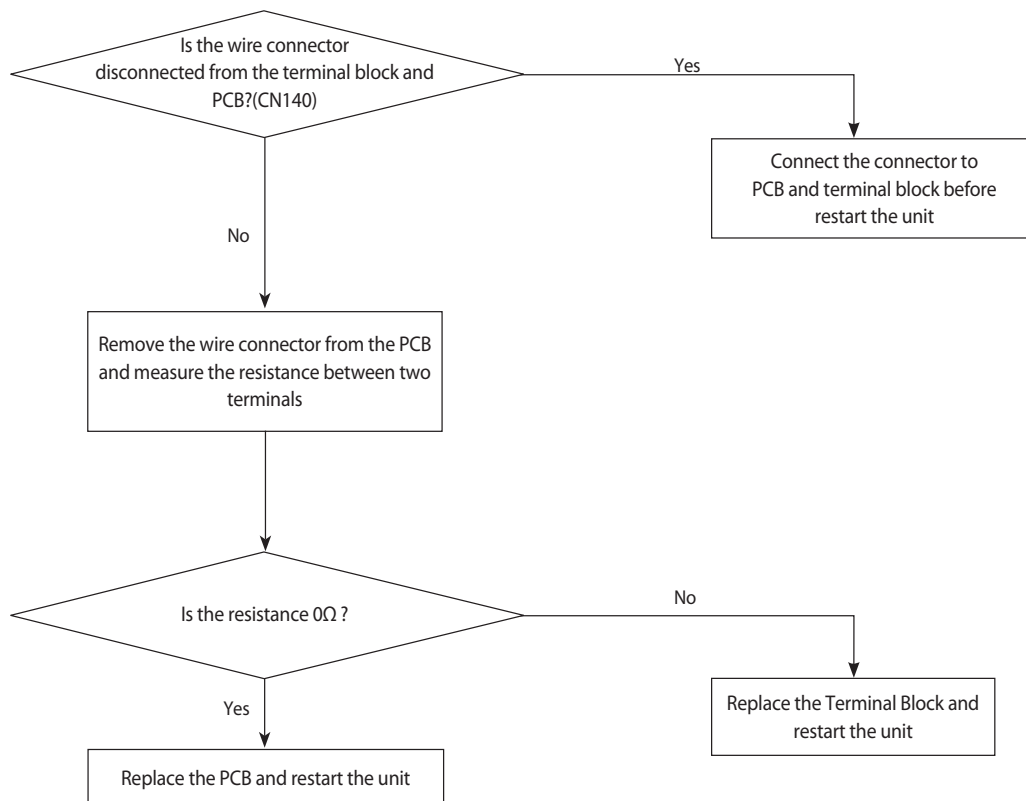

#### 4-2-5 Outdoor's service valve(Clog)

Indoor unit display	● (Operation) X (Defrost) X (Timer) ● (Fan) ● (Filter)
Wire remote controller display	E422
Symptom	Clogging of outdoor's service valve
Failure	Valve clog

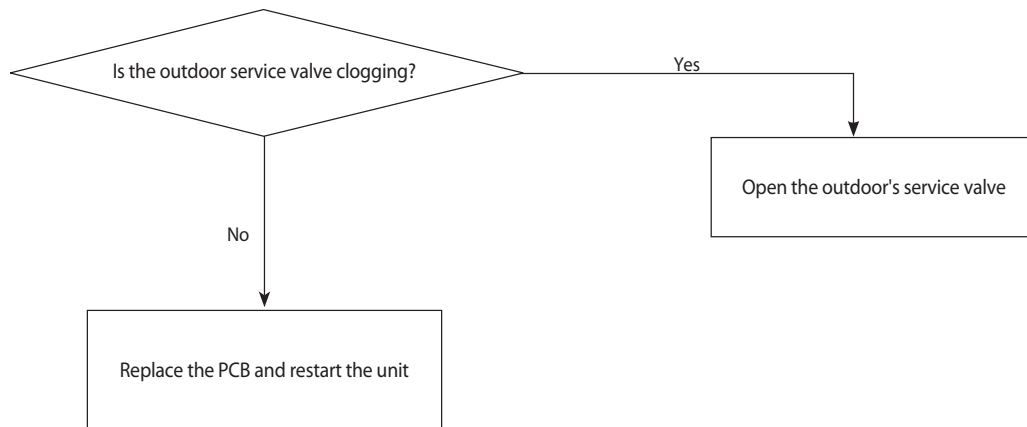

## 4-2-6 float switch(Open)

Indoor unit display	X (Operation) X (Defrost) X (Timer) ● (Fan) ● (Filter)
Wire remote controller display	E153
Symptom	2nd Detection of the float switch
Failure	Float switch open

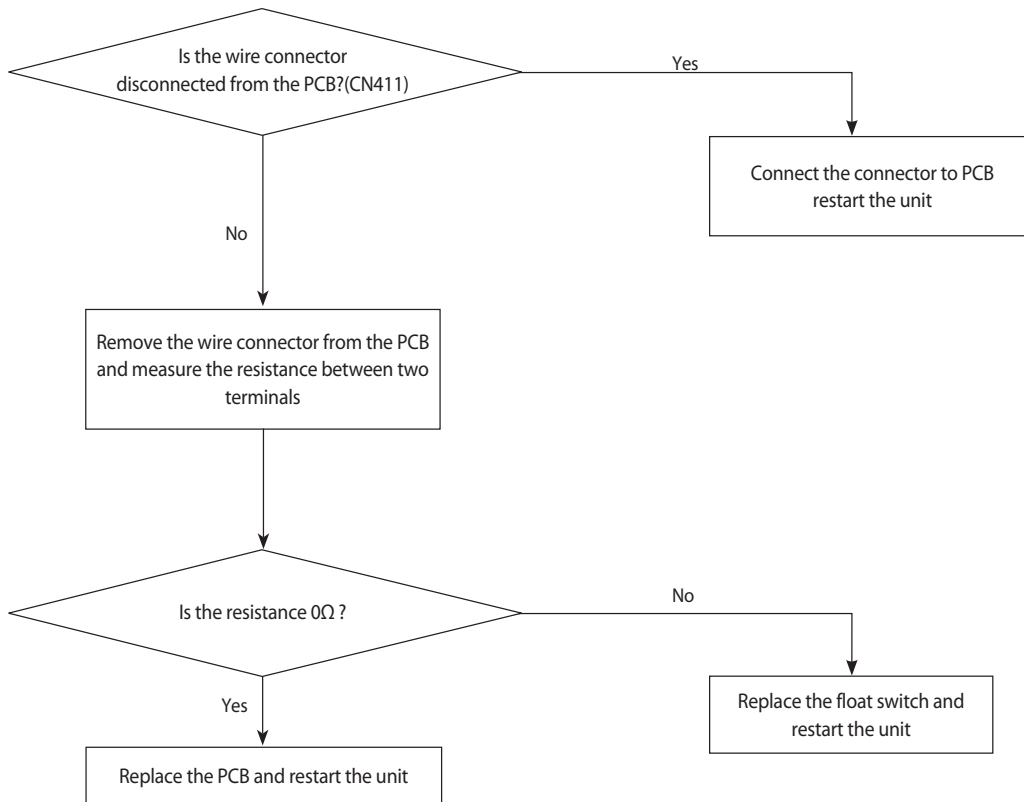

#### 4-2-7 EEPROM error

Indoor unit display	● (Operation) ● (Defrost) ● (Timer) ● (Fan) ● (Filter)
Wire remote controller display	E162
Symptom	EEPROM PCB disconnected from the MAIN PCB
Failure	Option error

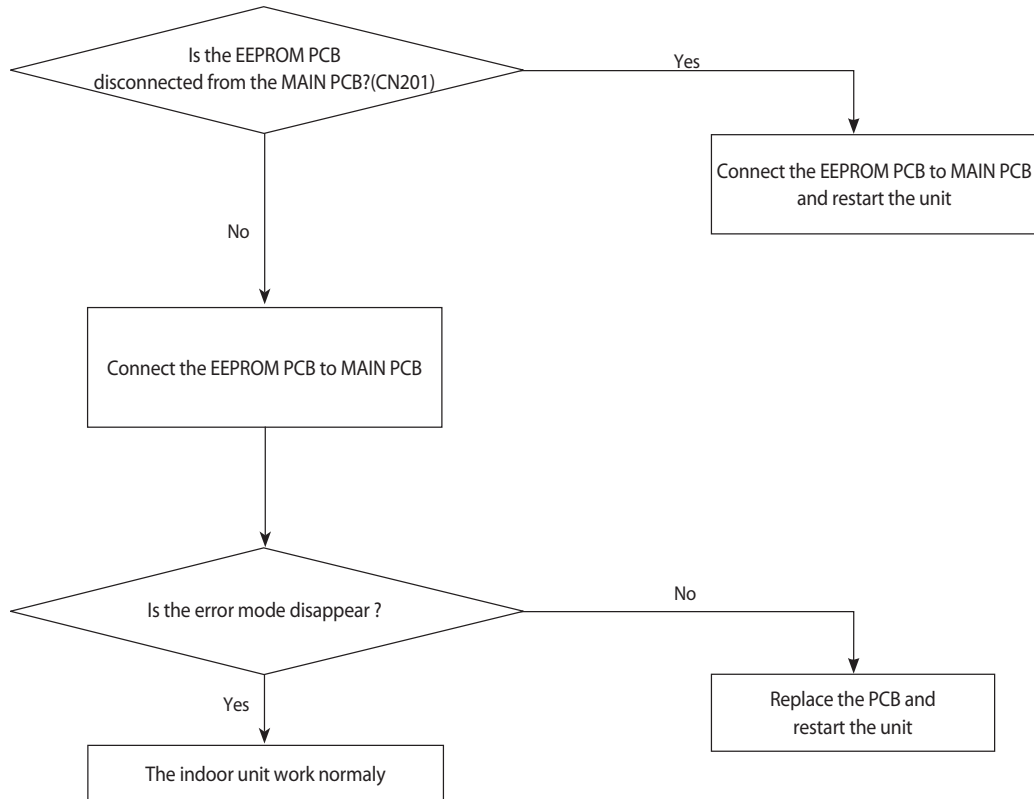

#### 4-2-8 Option error

Indoor unit display	● (Operation) ● (Defrost) ● (Timer) ● (Fan) ● (Filter)
Wire remote controller display	E163
Symptom	EEPROM option setting error
Failure	Option error

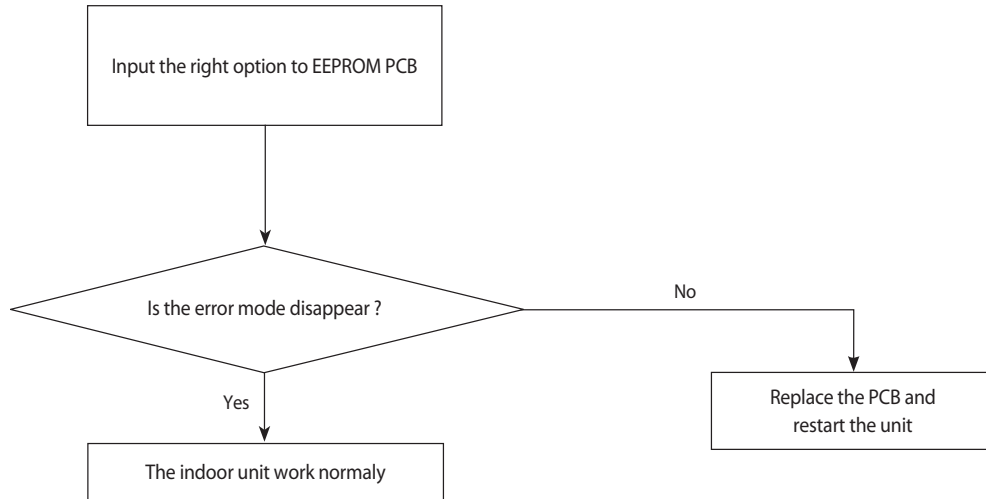

## 4-3 Setting Option Setup Method

▶ Setting the option code with wireless remote is available if receiver kit is installed. Please use the proper wireless remote such as MR-EH00U which set 24 digit option code. Following is the instruction of setting option code with wired remote(MWR-WE10N).

In order to set the indoor unit option code use the wired remote controller and follow the directions below.

SEG1	SEG2	SEG3	SEG4	SEG5	SEG6
0	*	*	*	*	*

Page number

SEG7	SEG8	SEG9	SEG10	SEG11	SEG12
1	*	*	*	*	*

Page number

SEG13	SEG14	SEG15	SEG16	SEG17	SEG18
2	*	*	*	*	*

Page number

SEG19	SEG20	SEG21	SEG22	SEG23	SEG24
3	*	*	*	*	*

Page number

- 1) Press the **Set** and **ESC** buttons at the same time for more than 3 seconds and then a Main menu will be displayed.
- 2) Press the **Left/Right** button to select **4** and then press **Right** button to enter a Sub-menu setting screen.
- 3) Press the **Left/Right** button to select **2** and then press **Right** button to enter a Indoor unit option code setting screen.

**NOTE** • The first digit represents the page number and the remaining five digits are option codes.  
 • The option code which is currently setting will flicker.

- 4) Press the **Left/Right** button to set the option code in order. Press **Right** button to go to the next page.
- 5) Press the **Set** button to save and complete the option setting.
- 6) Press the **ESC** button to exit to normal mode.

**NOTE** • Press the **ESC** button anytime during setup to exit without setting.

**CAUTION** • Option code will not be applied if you don't press the **Set** button.  
 • Setting indoor unit option code is only possible in Master wired remote controller. You can only check the indoor unit option code in Slave wired remote controller.  
 • Setting indoor unit option code is possible when one indoor unit is connected. If more than 2 indoor units are connected, you can only check the Master indoor unit option code.



## 4-4 Setting an indoor unit address and installation option

Set the indoor unit address and installation option with remote controller option. Set the each option separately since you cannot set the ADDRESS setting and indoor unit installation setting option at the same time. You need to set twice when setting indoor unit address and installation option.

### Setting an indoor unit address

- 1) Press the **Set** and **ESC** buttons at the same time for more than 3 seconds and then a Main menu will be displayed.
- 2) Press the **Up** / **Down** button to select **4** and then press **Right** button to enter a Sub-menu setting screen.
- 3) Press the **Up** / **Down** button to select **1** and then press **Right** button to enter a Indoor Address setting screen.

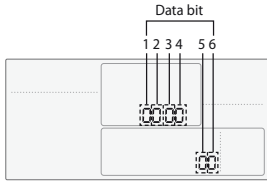

- NOTE**
- The Main/RMC Address which is currently setting will flicker.
  - Data bit 1 and 2 present Indoor unit main address checking
  - Data bit 3 and 4 present Indoor unit main address setting(outdoor unit reset is needed to set).
  - Data bit 5 and 6 present Indoor unit RMC address setting/checking.

- 4) Press the **Up** / **Down** button to set the Indoor unit Main/RMC Address.
- 5) Press the **Set** button to save and complete the option setting.
- 6) Press the **ESC** button to exit to normal mode.

- NOTE**
- Press the **ESC** button anytime during setup to exit without setting.
  - Address will not be applied if you don't press **Set** button.
  - Setting Main/RMC Address of an Indoor unit is available only with a master wired remote controller.

## Setting an indoor unit installation option

In order to check and set the indoor unit installation option code use the wired remote controller and follow the directions below.

- 1) Press the and buttons at the same time for more than 3 seconds and then a Main menu will be displayed.
- 2) Press the button to select **4** and then press button to enter a Sub-menu setting screen.
- 3) Press the button to select **3** and then press button to enter a Indoor unit installation option code setting screen.



NOTE

- The first digit represents the page number and the remaining five digits are installation option.
- The total option codes are 24 digits. You can set six digits at a time and it is distinguished by page number (0, 1, 2, 3).

- 4) Press the button to set the installation option code in order. Press button to go to the next page.

SEG1	SEG2	SEG3	SEG4	SEG5	SEG6
0	2	RESERVED	Exterior temperature sensor	Central control	RESERVED
SEG7	SEG8	SEG9	SEG10	SEG11	SEG12
1	Drain pump	Use of Hot Coil	Use of Electric Heater	RESERVED	Master / Slave
SEG13	SEG14	SEG15	SEG16	SEG17	SEG18
2	External control	External control output	S-Plasma ion	Buzzer	Number of hours using filter
SEG19	SEG20	SEG21	SEG22	SEG23	-
3	Individual control of a remote controller	Heating setting compensation	RESERVED	Away Set OFF Timer	-





CAUTION



- SEG8 of the installation option code should be "2" when PCB is changed.  
(Since the indoor unit is drained by a drain pump, installation option code setting is needed.)

Option No. : 02XXXX-1XXXX-2XXXX-3XXXX

Option	SEG1		SEG2		SEG3		SEG4		SEG5		SEG6	
Explanation	PAGE		MODE		RESERVED		Use of external temperature sensor		Use of central control		RESERVED	
Indication and Details	Indication	Details	Indication	Details			Indication	Details	Indication	Details		
	0		2				0	Disuse	0	Disuse		
					1	Use	1	Use				
Option	SEG7		SEG8		SEG9		SEG10		SEG11		SEG12	
Explanation	PAGE		Use of drain pump		Use of Hot Coil		Use of Electric Heater		RESERVED		Master / Slave	
Indication and Details	Indication	Details	Indication	Details	Indication	Details	Indication	Details			Indication	Details
	1		0	Disuse	0	Disuse	0	Disuse			0	slave
			1	Use	1	Use	1	Use			1	master
			2	Use + 3minute delay	-	-	-	-	-	-		
Option	SEG13		SEG14		SEG15		SEG16		SEG17		SEG18	
Explanation	PAGE		Use of external control		Setting the output of external control		S-Plasma ion		Buzzer control		Number of hours using filter	
Indication and Details	Indication	Details	Indication	Details	Indication	Details	Indication	Details	Indication	Details	Indication	Details
	2		0	Disuse	0	Thermo on	0	Disuse	0	Use of buzzer	2	1000 Hour
			1	ON/OFF Control	1	Operation on	1	Use	1	Non use of buzzer	6	2000 Hour
			2	OFF Control								
3	WINDOW ON/OFF Control											
Option	SEG19		SEG20		SEG21		SEG22		SEG23		-	
Explanation	PAGE		control of a remote controller		Heating setting compensation		RESERVED		Away Set OFF Timer		-	
Indication and Details	Indication	Details	Indication	Details	Indication	Details			Indication	Details		
	3		0 or 1	Indoor 1	0	Disuse			0 or 1	Auto Set OFF 30Min.		
			2	Indoor 2	1	2°C			2	Auto Set OFF 60Min.		
			3	Indoor 3	2	5°C	3	Auto Set OFF 120Min.				
4	Indoor 4	4	Auto Set OFF 180Min.									

- Press the  button to save and complete the option setting.
- Press the  button to exit to normal mode.

 NOTE

- Press  button anytime during setup to exit without setting.
- Option code will not be applied if you don't press  button.
- Setting Installation option code is available only with a master wired remote controller.
- Setting Installation option code is available when there is one on one connection between a wired remote controller and an indoor unit.

## ■ Option code

Model		AC018JNHDC	AC024JNHDC
Static Pressure(inH <sub>2</sub> O)	Static Pressure(mmAq)	Option code for indoor unit	
0≤P≤0.12	0≤P≤3	01C0EC-1C8424-27343B-370005	01C0EC-1C747C-274750-370005
0.12<P≤0.20	3<P≤5	01C0EC-1C5468-27343B-370005	01C0EC-1C54AF-274750-370005
0.20<P≤0.30	5<P≤7.5	01C0EC-1C54CE-27343B-370005	01C0EC-1C55E6-274750-370005
0.30<P≤0.40	7.5<P≤10	01C0EC-1C5924-27343B-370005	01C0EC-1C595A-274750-370005
0.40<P≤0.50	10<P≤12.5	01C0EC-1C596A-27343B-370005	01C0EC-1C5AB0-274750-370005
0.50<P≤0.60	12.5<P≤15	01C0EC-1C59CE-27343B-370005	01C0EC-1C5AE3-274750-370005

Model		AC030JNHDC	AC036JNHDC
Static Pressure(inH <sub>2</sub> O)	Static Pressure(mmAq)	Option code for indoor unit	
0.12≤P≤0.16	3≤P≤4	0100EC-1A55D4-275A64-370005	0100EC-1A5902-276470-370005
0.16<P≤0.28	4<P≤7	0100EC-1A5927-275A64-370005	0100EC-1A595A-276470-370005
0.28<P≤0.40	7<P≤10	0100EC-1A594A-275A64-370005	0100EC-1A598C-276470-370005
0.40<P≤0.50	10<P≤12.5	0100EC-1A598C-275A64-370005	0100EC-1A59BE-276470-370005
0.50<P≤0.60	12.5<P≤15	0100EC-1A59BE-275A64-370005	0100EC-1A5AE0-276470-370005
0.60<P≤0.70	15<P≤17.5	0100EC-1A5AE0-275A64-370005	0100EC-1A5E12-276470-370005
0.70<P≤0.80	17.5<P≤20	0100EC-1A5E02-275A64-370005	0100EC-1A5E34-276470-370005

Model		AC042JNHDC	AC048JNHDC
Static Pressure(inH <sub>2</sub> O)	Static Pressure(mmAq)	Option code for indoor unit	
0.16≤P≤0.20	4≤P≤5.2	0100EC-1A194D-277D8C-370005	0100EC-1A1A81-278CA0-370005
0.20<P≤0.30	5.2<P≤7.5	0100EC-1A597E-277D8C-370005	0100EC-1A5AA2-278CA0-370005
0.30<P≤0.40	7.5<P≤10	0100EC-1A5AA1-277D8C-370005	0100EC-1A5AD4-278CA0-370005
0.40<P≤0.50	10<P≤12.5	0100EC-1A5AD3-277D8C-370005	0100EC-1A5E06-278CA0-370005
0.50<P≤0.60	12.5<P≤15	0100EC-1A5E06-277D8C-370005	0100EC-1A5E38-278CA0-370005
0.60<P≤0.70	15<P≤17.5	0100EC-1A5E38-277D8C-370005	0100EC-1A5E6A-278CA0-370005
0.70<P≤0.80	17.5<P≤20	0100EC-1A5E5A-277D8C-370005	0100EC-1A5E7D-278CA0-370005

## 4-5 Items to be checked first

1. The input voltage should be rating voltage  $\pm 10\%$  range.  
The air conditioner may not operate properly if the voltage is out of this range.
2. Is the link cable linking the indoor unit and the outdoor unit linked properly?  
The indoor unit and the outdoor unit shall be linked by 4 cables.  
Check the terminals if the indoor unit and outdoor unit are properly linked by the same number of cables.  
Otherwise the air conditioner may not operate properly.
3. When a problem occurs due to the contents illustrated in the table below it is a symptom not related to the malfunction of the air conditioner.

No	Operation of air conditioner	Explanation
1	In a COOL operation mode, the compressor does not operate at a room temperature higher than the setting temperature that the INDOOR FAN should operate. <b>[In case of heat pump model]</b> In a HEAT operation mode, the compressor does not operate at a room temperature lower than the setting temperature that indoor fan should operate.	In happens after a delay of 3 minutes when the compressor is reoperated. The same phenomenon occurs when a power is on. As a phenomenon that the compressor is reoperated after a delay of 3 minutes, the indoor fan is adjusted automatically with reference to a temperature of the air blew.
2	Compressor stops operation intermittently in DRY(☁) mode.	Compressor operation is controlled automatically in DRY mode depending on the room temperature and humidity.
3	<b>[In case of heat pump model]</b> Compressor of the outdoor unit is operating although it is turned off in a HEAT mode.	When the unit is turned off while de-ice is activated, the compressor continues operation for up to 12 minutes(maximum) until the deice is completed.
4	<b>[In case of heat pump model]</b> The compressor and indoor fan stop intermittently in HEAT mode.	The compressor and indoor fan stop intermittently if room temperature exceeds a setting temperature in order to protect the compressor from overheated air in a HEAT mode.
5	<b>[In case of heat pump model]</b> Indoor fan and outdoor fan stop operation intermittently in a HEAT mode.	The compressor operates in a reverse cycle to remove exterior ice in a HEAT mode, and indoor fan and outdoor fan do not operate intermittently for within 20% of the total heater operation

## 5. PCB Diagram and Part List

### 5-1 Indoor Unit

AC018JNHDCH / AC024JNHDCH

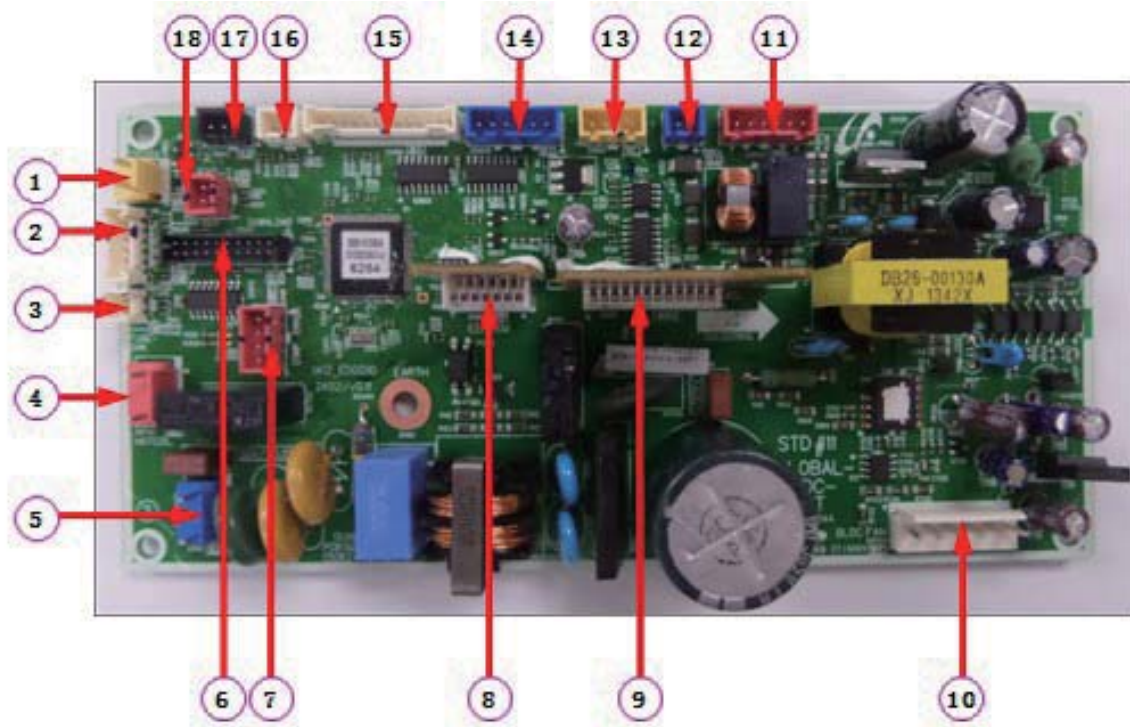

No	Part Code	Local	Function	Description
1	3711-000179	CN103	DRAIN	YW396-02V YEL
2	3711-004236	CN413	EVA DIS/OUT SENSOR	SMW200-06P WHT
3	3711-003942	CN140	Fuse Check	SMW200-02P WHT
4	3711-003407	CN702	Comp Signal	YW396-03AV RED
5	3711-003404	CN101	MAIN POWER	YW396-03AV BLU
6	3711-002001	CN301	DOWNLOAD	YDW200-20
7	3711-000939	CN81	COMP ERROR	SMW250-04 RED
8	3711-007817	CN201	EPPROM	B7P-MQ WHT
9	3711-004773	CN311	2 WIRE	BMW200-12 WHT
10	3711-000296	CN703	BLDC FAN	YW396-06V WHT
11	3711-001037	CN302	COMM	SMW250-06 RED
12	3711-000795	CN804	VEN	SMW250-02 BLU
13	3711-000941	CN801	SPI	SMW250-04 YEL
14	3711-001036	CN808	EEV	SMW250-06 BLU
15	3711-003895	CN501	DISPLAY	SMW200-13P WHT
16	3711-000015	CN412	ROOM SENSOR	SMW250-02 WHT
17	3711-000794	CN411	FLOAT-SW	SMW250-02 BLK
18	3711-000796	CN83	EXT-T	SMW250-02 RED

AC030JNHDCH / AC036JNHDCH / AC042JNHDCH / AC048JNHDCH

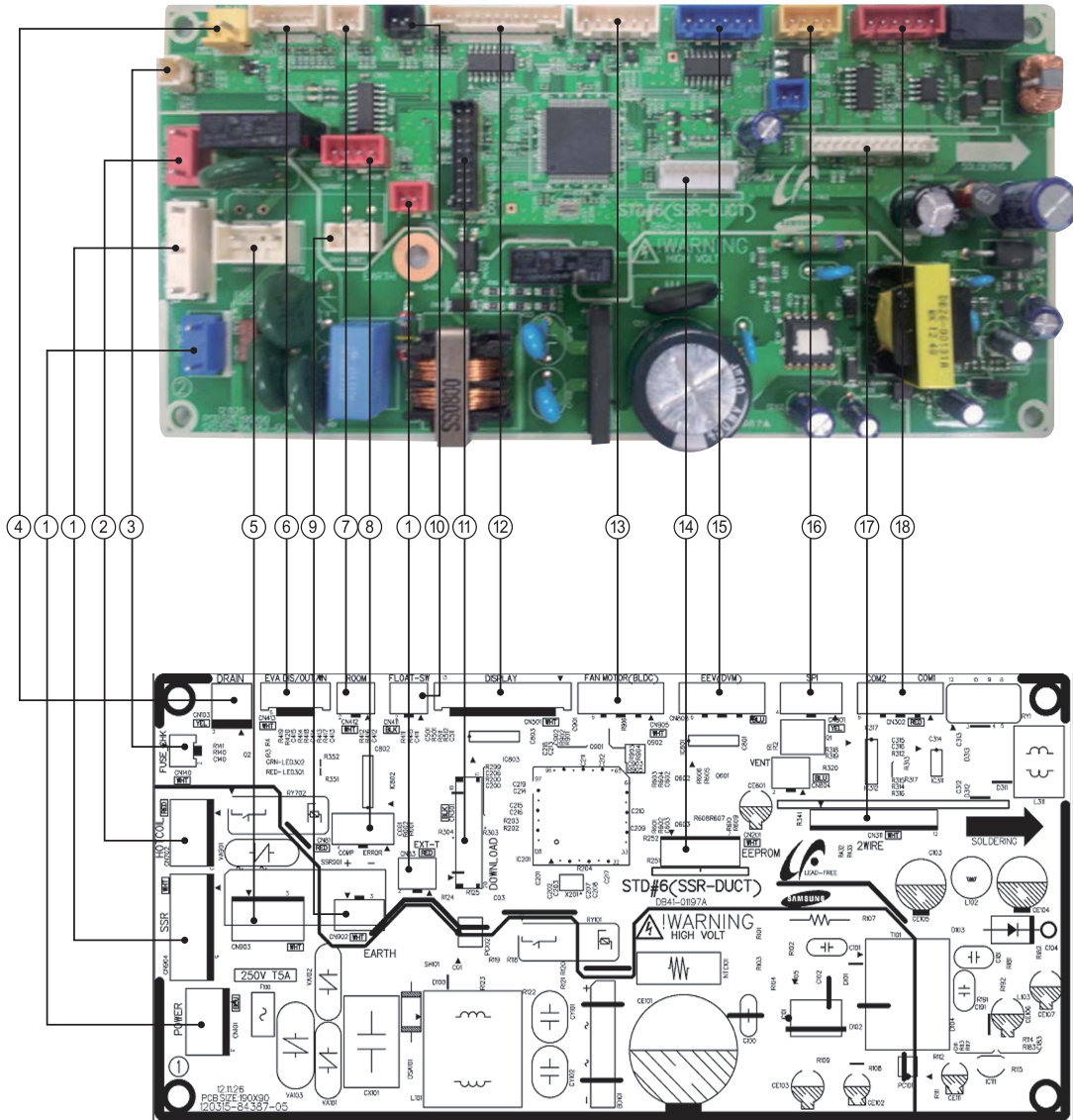

<b>CN904-SSR MOTOR</b> #1: N #2: L #3: N	<b>CN702-HOT COIL</b> #1: L #2: N	<b>CN140-FUSE CHECK</b> #1:FUSE CHECK #2:GND	<b>CN103-DRAIN PUMP</b> #1: 12V #2: GND
<b>CN903-SSR AC 제어</b> #1: L Input #2: L Output	<b>CN413-온도 센서</b> #1 : EVA IN TEMP #2,4,6: GND #3 : EVA OUT TEMP #5 : DISCHARGE TEMP	<b>CN412-ROOM 온도센서</b> #1: 온도 입력 #2: GND	<b>CN81-EXTERNAL CONTROL OUT</b> #1,3: 12V #2: ERROR CHECK OUT #4: COM CHK OUT
<b>CN902- SSR DC 출력</b> #1: 12V #2: MOTOR SSR OUT	<b>CN83-EXTERNAL CONTROL</b> #1: GND #2: EXT CTRL	<b>CN301-MICOM DOWNLOAD</b>	<b>CN501-DISPLAY</b> #1:12V #2~6:LED 제어 #7: BZ1 #8: 리모컨 신호 출력 #9: AUTO SW #10: REMOCON INT #11:GND #12:VCC #13:BZ2
<b>CN905-BLDC MOTOR</b> #1:12V #2: GND #3: VCC #4: MOTOR SIGNAL PWM #5: MOTOR FEEDBACK #6:INRUSH OUT #12:VCC	<b>CN201-E2P 모듈</b>	<b>CN808-전동변</b> #1~4: 전동변 제어 #5,6: 12V	<b>CN801-SPI</b> #1,2:GND #3:SPI 제어
<b>CN311-2 선 통신</b>	<b>CN302-실내외기 통신 / 유선</b> #1,2:실내외기 통신 #3:12V #4:GND #5:유선리모컨 통신	<b>CN101-AC INPUT</b> #1: L #2: N	



## 5-2 Outdoor Unit

### 5-2-1 Main PCB

#### ■ AC018JXADCH

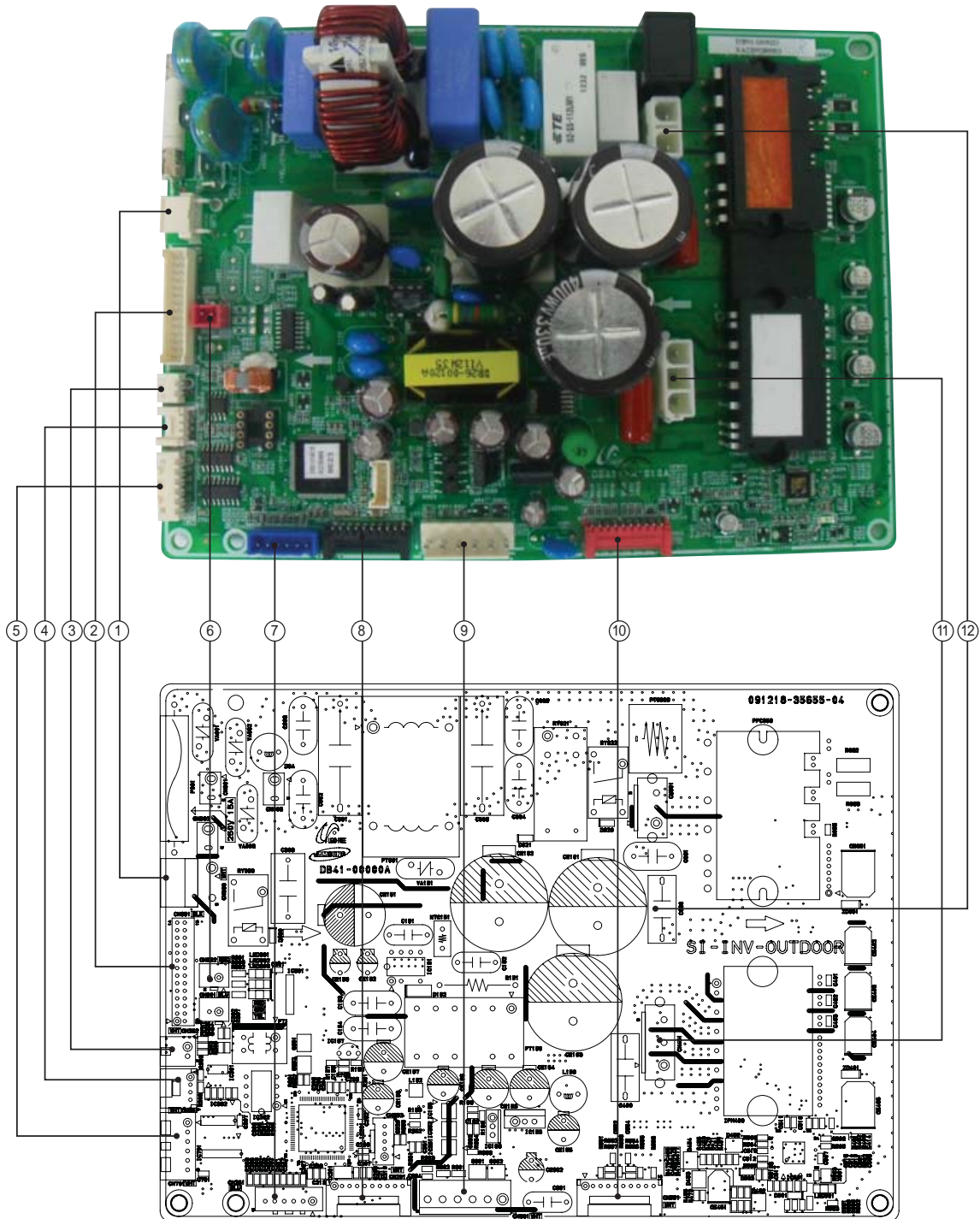

<p><b>CN030 : 4WAY VALVE</b> #1~#3 : AC220V</p>	<p><b>CN951 : SIGNAL TO SUB PCB</b> #1~#28 : SIGNAL TO SUB PCB</p>	<p><b>CN252 : THERMISTOR</b> #1~#2 : OLP THERMISTOR</p>	<p><b>CN851:S-NET Communication</b> #1 : DC12V #2 : RXD #3 : TXD #4 : GND</p>
<p><b>CN701 : EEV</b> #1~#5 : EEV SIGNAL #6 : DC12V</p>	<p><b>CN302:Communication(COM1)</b> #1 : COM1(F1) #2 : COM2(F2)</p>	<p><b>CN251 : THERMISTOR</b> #1~#2 : OUTDOOR THERMISTOR #3~#4 : DISCHARGE THERMISTOR #5~#6 : COND THERMISTOR</p>	<p><b>CN201 : Downloader</b> #1~#10 : Download</p>
<p><b>CN901 : BLDC MOTOR</b> #1: DV310V #3: GND #4: DC15V #5: FAN_PWM #6: FAN_Feedback</p>	<p><b>CN551: Downloader</b> #1~#10 : Download</p>	<p><b>CN451 : COMP POWER</b> #1 : COMP U-Phase #2 : COMP V-Phase #3 : COMP W-Phase</p>	<p><b>CN051 : Reactor</b> #1~#2 : Reactor</p>

## 5-2-2 SUB PCB

### ■ AC018JXADCH

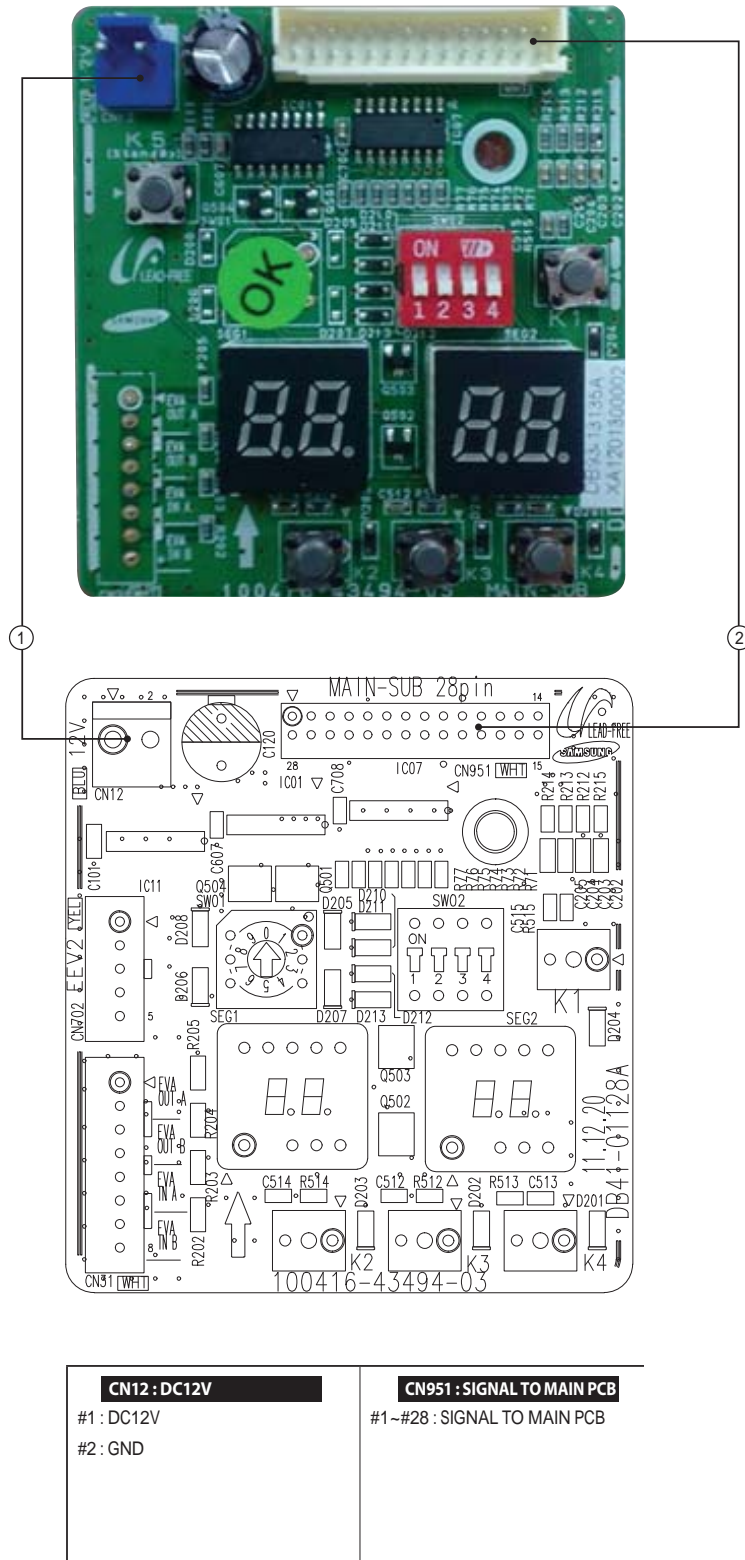

### 5-2-3 MAIN PCB

#### ■ AC024JXADCH, AC030JXADCH, AC036JXADCH, AC042JXADCH, AC048JXADCH

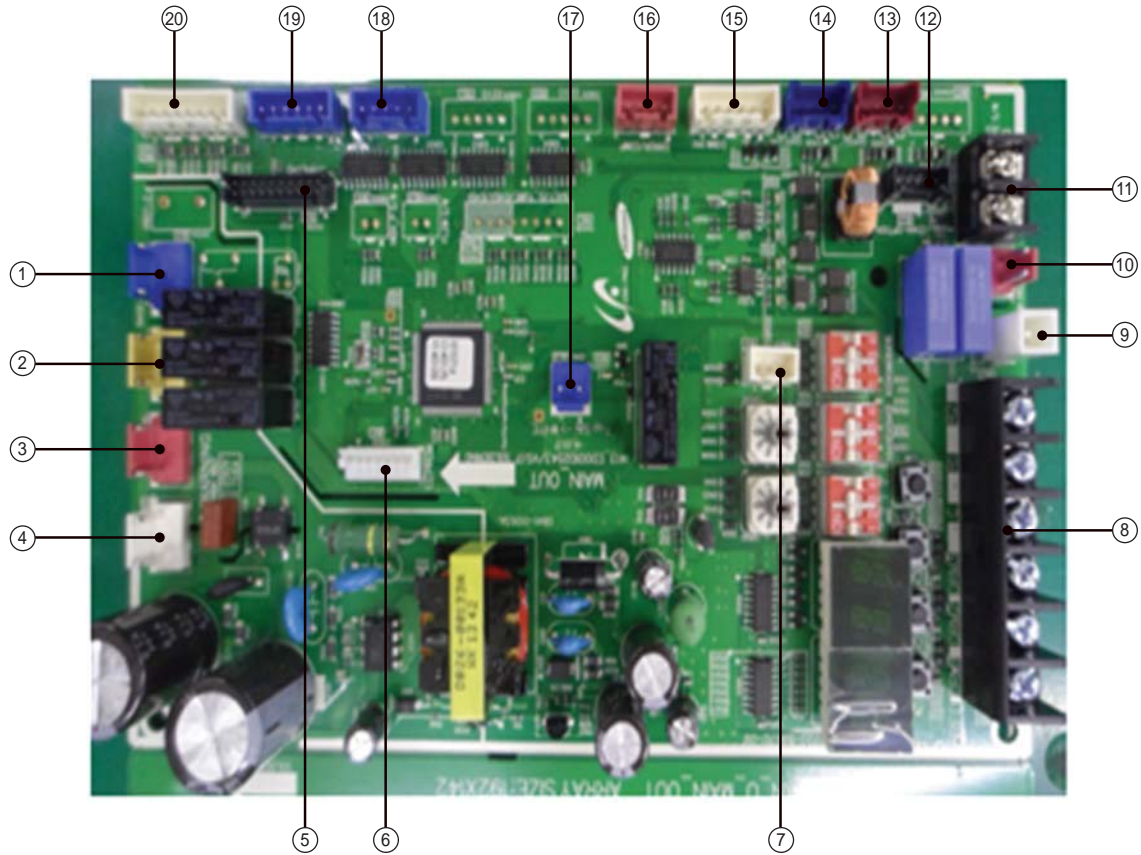

No	Part Code	Local	Function	Description
1	3711-003404	CN703	BASE-HEATER	YW396-03AV BLU
2	3711-003406	CN702	4WAY-1	YW396-03AV YEL
3	3711-003407	CN701	HOTGAS	YW396-03AV RED
4	3711-000203	CN101	POWER	YW396-03AV WHT
5	3711-002001	CN306	DOWNLOAD	YDW200-20P BLK
6	3711-007817	CN806	EEPROM	B7P-MQ WHT
7	3711-000024	CN501	MODE SELECTOR	SMW250-03 WHT
8	DB65-00320A	CN304	DRED	DAPC-2009-6P BLK
9	3711-000744	CN103	EARTH	YDW236-01 WHT
10	3711-000177	CN303	COMM-INDOOR	YW396-02V RED
11	3716-001162	CN003	QUIET S/W	BR-7623-2P BLK
12	3711-005096	CN302	COMM-OPTION	SMW200-05 BLK
13	3711-007069	CN402	HIGH PRESSURE S/W	B04B-XARK-1 RED
14	3711-007325	CN401	LOW PRESSURE S/W	B04B-XARK-1 BLU
15	3711-001038	CN305	COMM INV	SMW250-06 WHT
16	3711-000939	CN801	ERROR/COMP CHECK	SMW250-04 RED
17	3711-000176	CN12	DC12V	YW396-02V BLU
18	3711-000997	CN803	EEV1	SMW250-05 BLU
19	3711-001036	CN802	EEV4	SMW250-06 BLU
20	3711-001084	CN403	OUT TEMP/COND/DISQ/OLP	SMW250-08 WHT

## 5-2-4 INVERTER PCB

### ■ AC024JXADCH, AC030JXADCH, AC036JXADCH, AC042JXADCH, AC048JXADCH

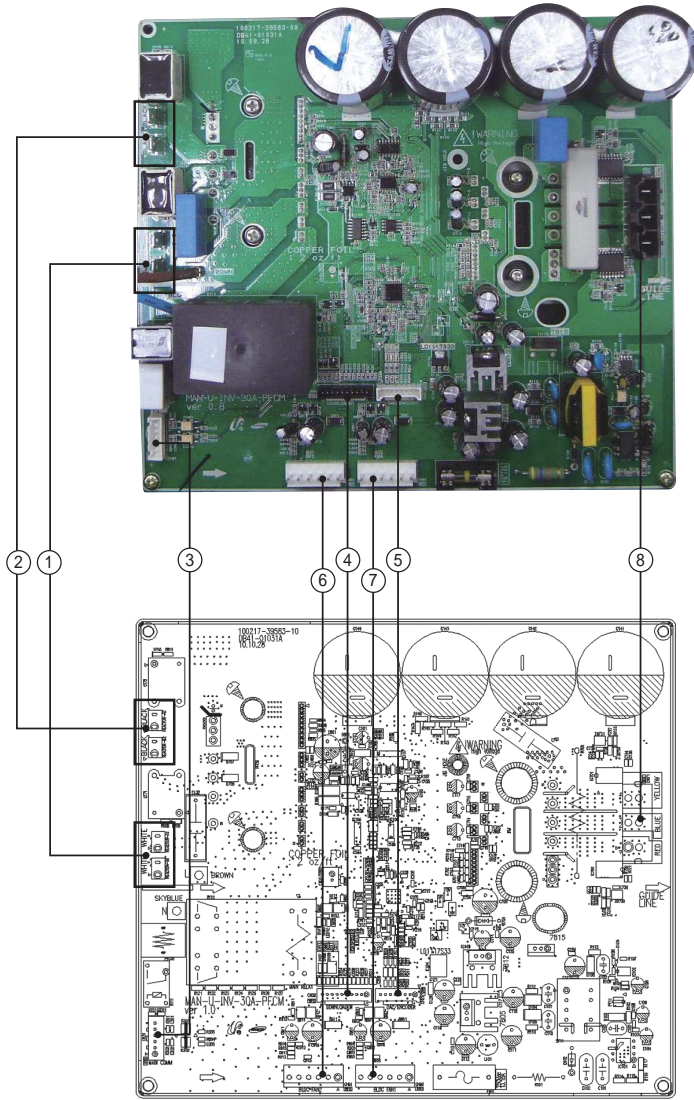

<p><b>Reactor-A1/B1</b> #Reactor-A2 : WHT #Reactor-B2 : WHT</p>	<p><b>Reactor-A2/B2</b> #Reactor-A2 : BLK #Reactor-B2 : BLK</p>	<p><b>CN50(2PIN/RED)-Communication</b> #1 : RXD, #2 : TXD #3 : GND, #4 : DC 5V #5 : DC 12V, #6 : INV. SMPS signal</p>	<p><b>CN22-Downloader</b> #1 : RXD_ATARO, #2 : TXD_ATARO #3, #8 : N.C, #4~#7 : DATA signal #9 : GND, #10 : DC 5V</p>
<p><b>CN21-DAC/ENCODER</b> For S/W engineer debugging</p>	<p><b>CN91-FAN2</b> #1 : DC 360V #2 : N.C #3 : GND #4 : DC 15V #5 : FAN RPM #6 : FAN RPM feedback</p>	<p><b>CN90-FAN1</b> #1 : DC 360V #2 : N.C #3 : GND #4 : DC 15V #5 : FAN RPM #6 : FAN RPM feedback</p>	<p><b>CN71-COMP.</b> #1 : COMP. U-phase(RED) #2 : COMP. V-phase(BLU) #3 : COMP. U-phase(YEL)</p>

## 5-2-5 EMI PCB

### ■ AC024JXADCH, AC030JXADCH, AC036JXADCH, AC042JXADCH, AC048JXADCH

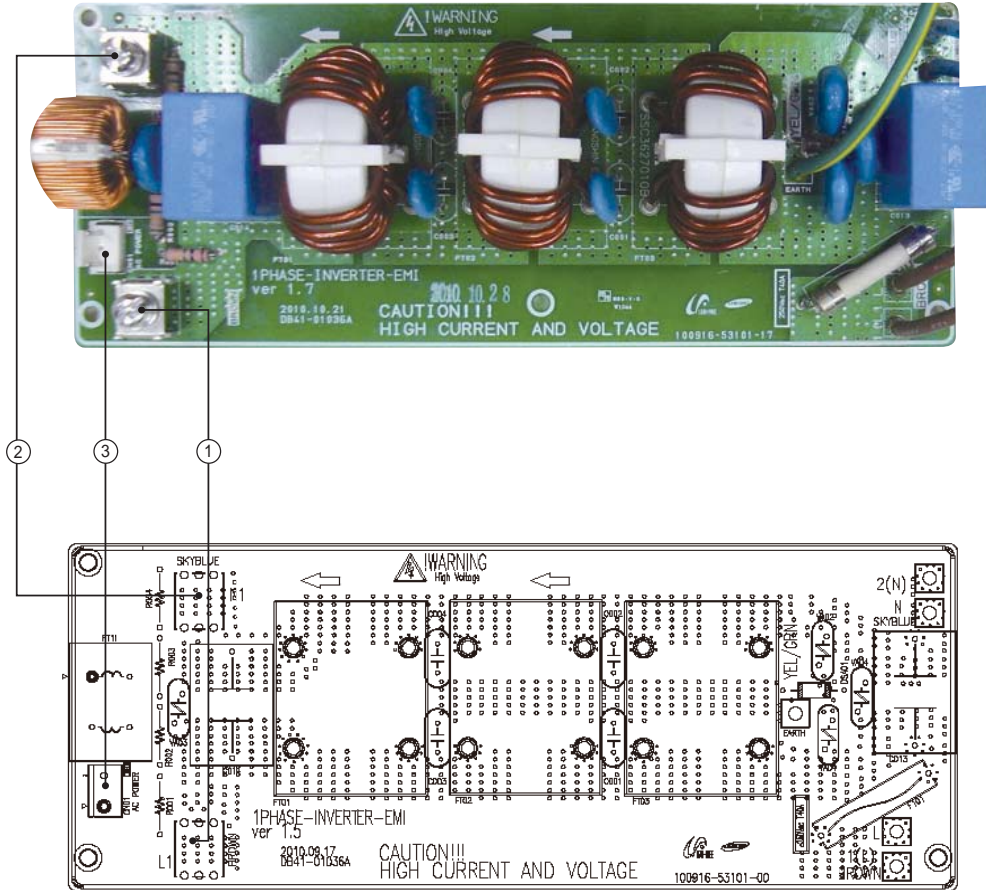

L1-AC POWER L phase	N1-AC POWER N phase	CN01-AC POWER
L1 : BRN	N1 : SKY-BLU	#1-#3 : AC 220~240V



■ AC030JNHDCH / AC036JNHDCH / AC042JNHDCH / AC048JNHDCH

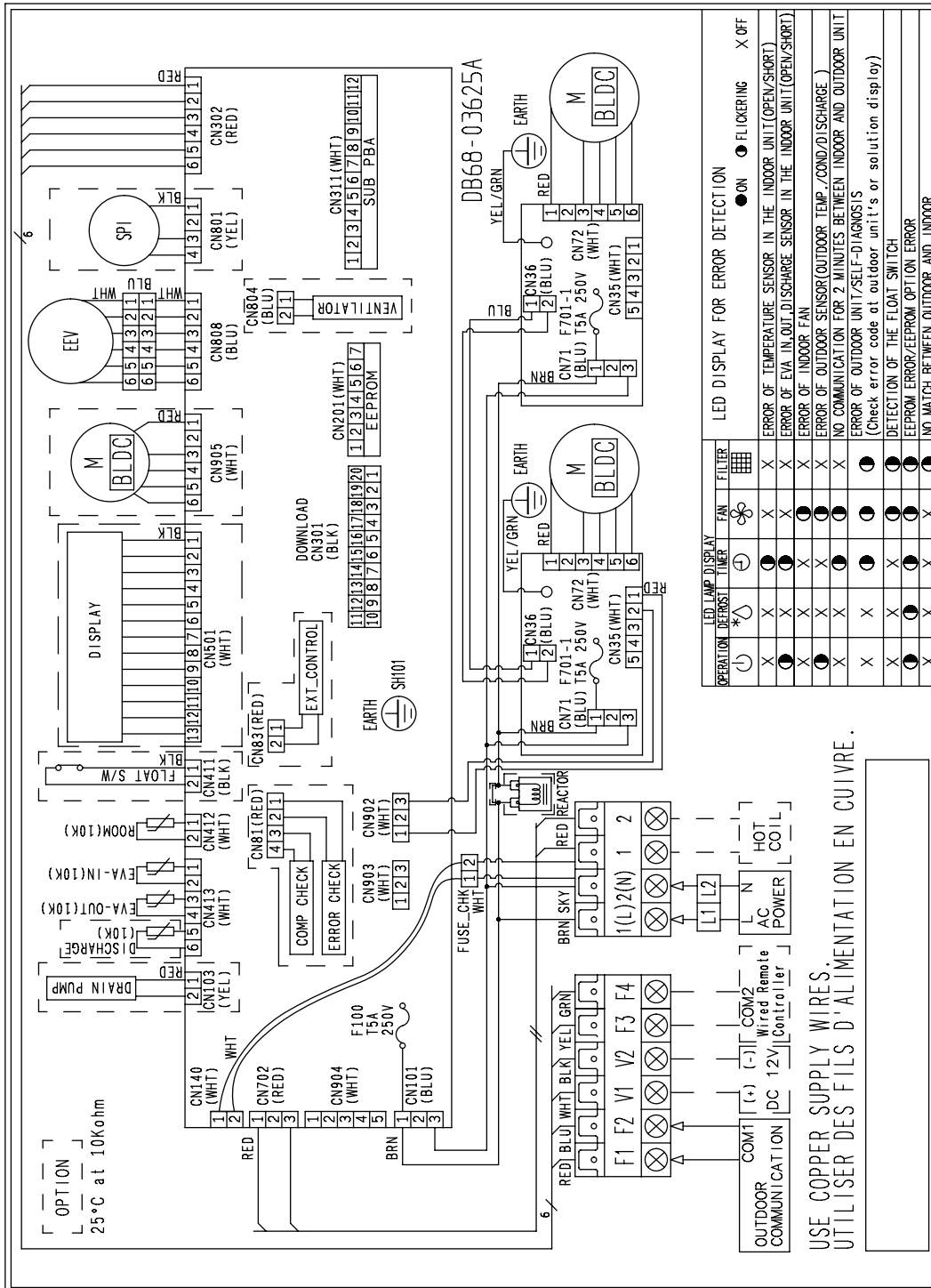

This Document can not be used without Samsung's authorization.



## 6-2 Outdoor unit

### ■ AC018JXADCH

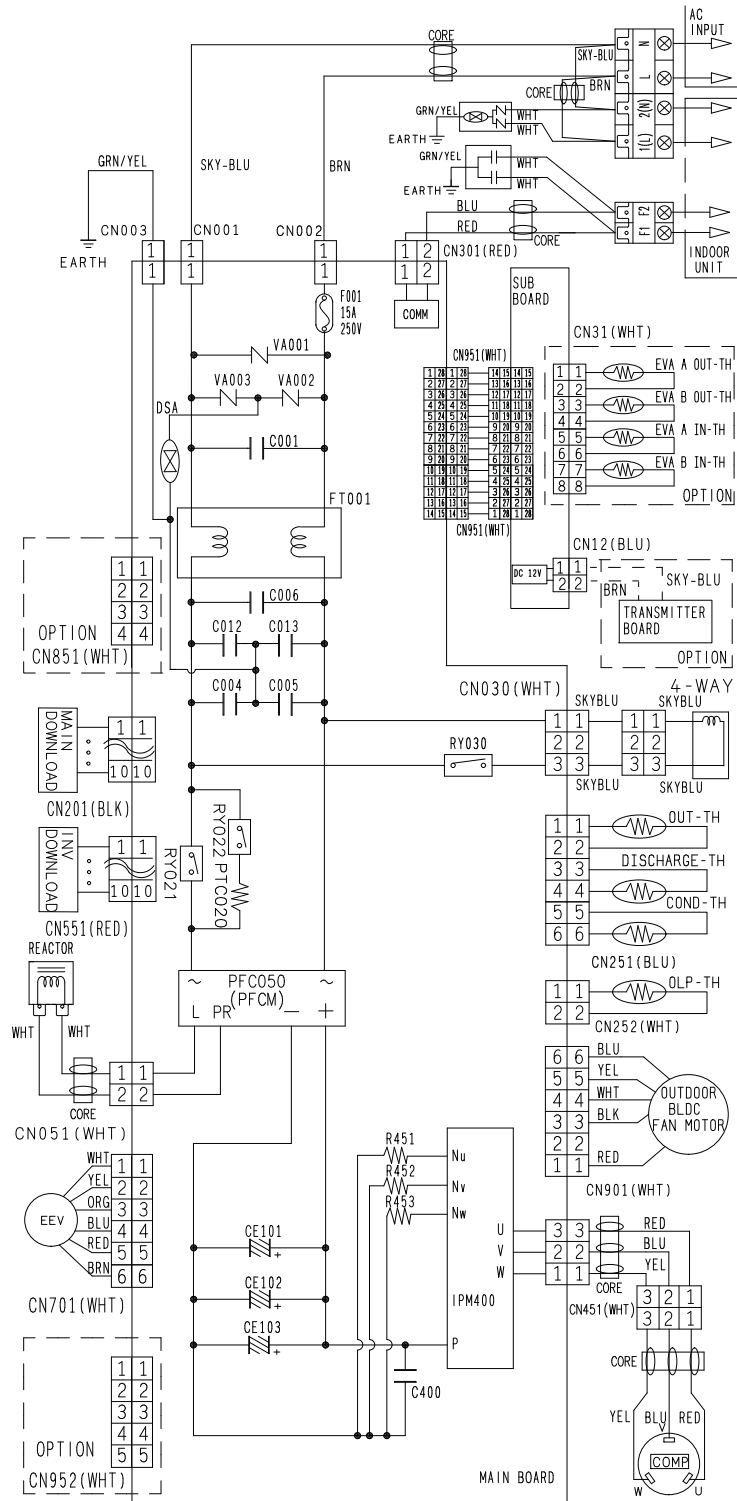

This Document can not be used without Samsung's authorization.



---

## 7. Preference Sheet

---

### 7-1 Refrigerating Cycle Diagram

---

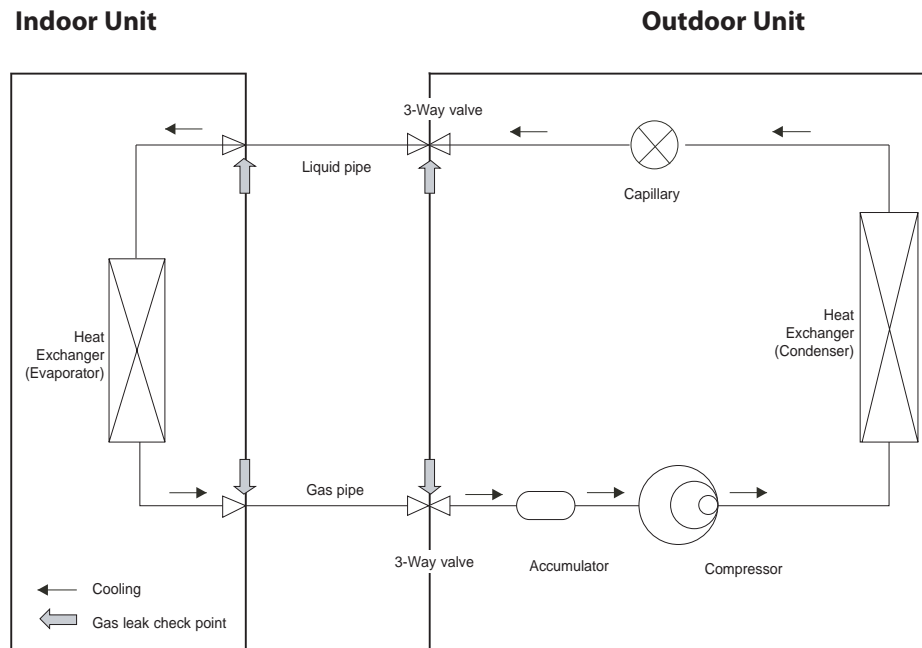

#### ■ CONDENSER

High temperature and high pressure gas state coolant discharged from the compressor is converted to a liquid state as it is cooled down by the heat emission in the outdoor condenser unit, and sent to the evaporator.

#### ■ COMPRESSOR

Low temperature and low pressure coolant is compressed and sent to the cycling system.

#### ■ EVAPORATOR

Liquid coolant sucked in through the capillary tubes cools down the room by absorbing the surrounding heat as it evaporates (converting from liquid to gas). (Absorbing heat required for evaporation)

#### ■ SERVICE VALVE

You can open the valve by turning the need valve counterclockwise using hex wrench, and it is used for vacuum, gas purging, coolant injection, coolant purging, and indoor-outdoor unit connection.

#### ■ ACCUMULATOR

Accumulator prevents the flow of liquid-state coolant into the compressor. (Liquid-state coolant flowing into the compressor will overload the compressor.)

## 7-2 Index for Model Name

### 7-2-1 Indoor Unit

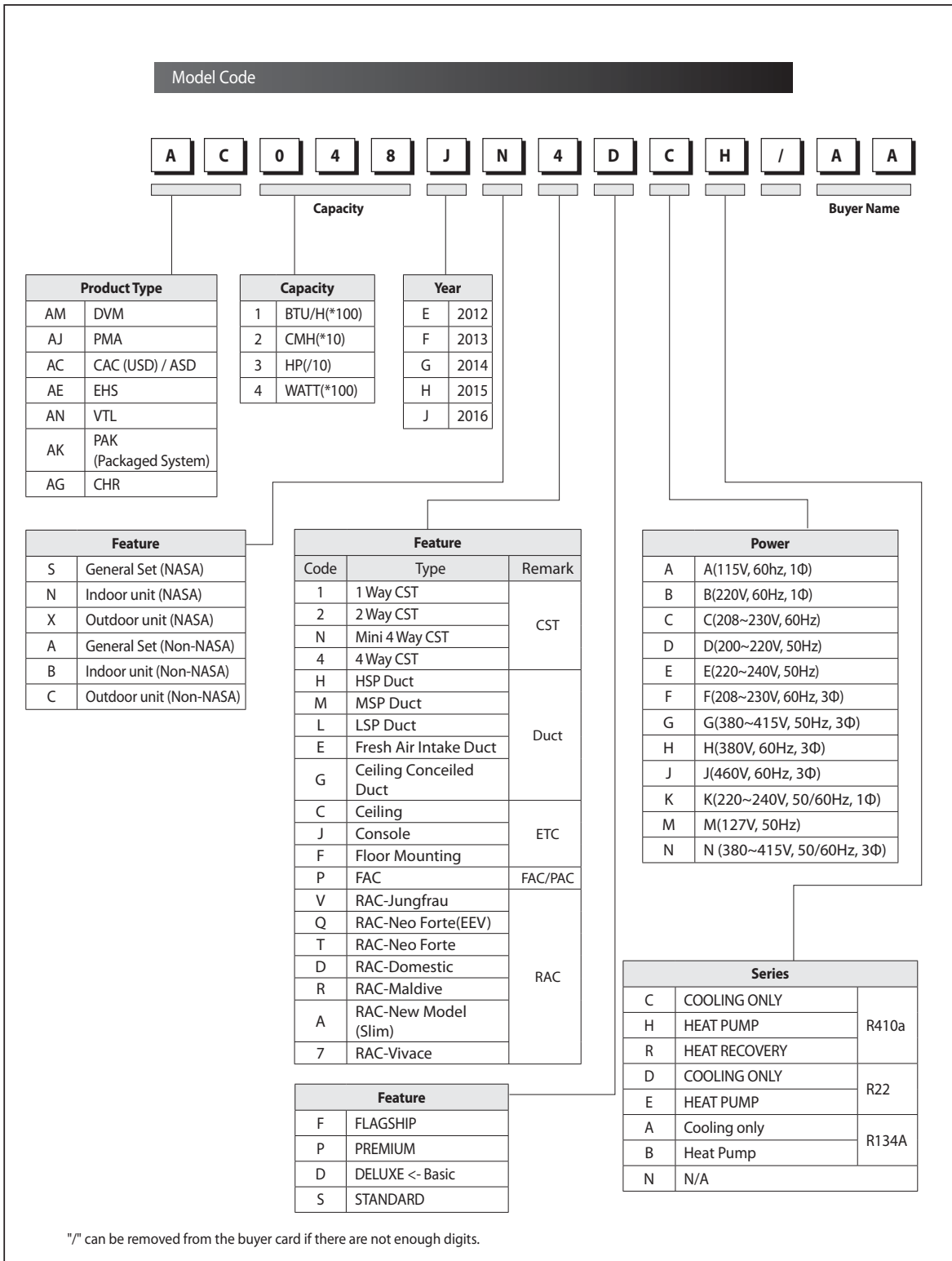





This Service Manual is a property of Samsung Electronics Co., Ltd.  
Any unauthorized use of Manual can be punished under applicable  
International and/or domestic law.

© Samsung Electronics Co., Ltd May 2015.  
Printed in China.

---