



**SAMSUNG**

# SYSTEM AIR CONDITIONER

4 WAY CASSETTE SERIES

	INDOOR UNIT	OUTDOOR UNIT
Model:	AC018JN4DCH/AA	AC018JXADCH/AA
	AC024JN4DCH/AA	AC024JXADCH/AA
	AC030JN4DCH/AA	AC030JXADCH/AA
	AC036JN4DCH/AA	AC036JXADCH/AA
	AC042JN4DCH/AA	AC042JXADCH/AA
	AC048JN4DCH/AA	AC048JXADCH/AA

# ***SERVICE*** Manual

## AIR CONDITIONER



## CONTENTS

1. Precautions
2. Product Specifications
3. Disassembly and Reassembly
4. Troubleshooting
5. PCB Diagram
6. Wiring Diagram
7. Reference Sheet

# Contents

<b>1. Precautions .....</b>	<b>1-1</b>
1-1 Precautions for the Service.....	1-1
1-2 Precautions related to static electricity and PL.....	1-1
1-3 Precautions related to product safety .....	1-2
1-4 Other precautions .....	1-2
<b>2. Product Specifications.....</b>	<b>2-1</b>
2-1 The Feature of Product .....	2-1
2-1-1 Features.....	2-1
2-2 Product Specifications .....	2-4
2-3 Specifications of optional items.....	2-6
2-3-1 Accessories.....	2-6
2-3-2 Filter specifications .....	2-10
<b>3. Disassembly and Reassembly.....</b>	<b>3-1</b>
3-1 Indoor unit .....	3-2
3-2 Outdoor Unit.....	3-8
<b>4. Troubleshooting .....</b>	<b>4-1</b>
4-1 Setting an indoor unit address and installation option .....	4-1
4-1-1 The procedure of setting option.....	4-1
4-1-2 The procedure of setting option.....	4-2
4-1-3 Order for Setting Options (Wired Remote Controller) .....	4-5
4-1-4 Setting an indoor unit installation option (Suitable for the condition of each installation location) .....	4-6
4-1-5 Changing a particular option .....	4-8
4-1-6 Option code for each model.....	4-9
4-2 Items to check before diagnostics .....	4-10
4-2-1 Test run mode and View Mode .....	4-10
4-2-2 Eco Mode [Power Saving Mode].....	4-12
4-2-3 Four directions cassette type .....	4-13
4-2-4 Wired remote controller.....	4-14
4-3 Troubleshooting by symptoms.....	4-17
4-3-1 Indoor temperature sensor (open/short).....	4-17
4-3-2 Indoor heat exchanger temperature sensor (open/short).....	4-18
4-3-3 Indoor FAN error.....	4-19
4-3-4 Communication error after finishing Tracking.....	4-20
4-3-5 Indoor unit float sensor error .....	4-21
4-3-6 EEPROM circuit failure.....	4-22
4-3-7 Thermal Fuse Open Error .....	4-23
4-3-8 When the outdoor unit power is not ON – Initial Diagnosis : 3-phase products .....	4-24
4-3-9 Indoor/outdoor communication error (1 min.) (Error Code: E202).....	4-28

# Contents

4-3-10 Communication error between outdoor unit INV ↔ MAIN MICOM (1 min.) (Error Code: E203).....	4-30
4-3-11 External Sensor Error (Error Code: E221, E231, E251, E320).....	4-31
4-3-12 Outdoor Unit Fan Error (Error Code: E458, E475).....	4-32
4-3-13 Error of Compressor Startup and Rotation (Error Code: E461, E467).....	4-33
4-3-14 Error of under-current error / PFC over-current (Error Code: E462, E484).....	4-35
4-3-15 IPM Over-current Error (Error Code: E464).....	4-36
4-3-16 DC LINK Over-current and Low-voltage Error (Error Code: E466).....	4-39
4-3-17 Gas Leakage Error (Error Code: E554 ).....	4-41
4-3-18 Pipe Blocking Error (Error Code: E422).....	4-43
4-3-19 Other.....	4-44
<b>5. PCB Diagram and Parts List.....</b>	<b>5-1</b>
5-1 Indoor Unit.....	5-1
5-1-1 MAIN PCB.....	5-1
5-1-2 Panel PCB.....	5-3
5-2 Outdoor Unit.....	5-4
5-2-1 MAIN PCB.....	5-4
5-2-2 SUB PCB.....	5-6
5-2-3 MAIN PCB.....	5-7
5-2-4 INVERTER PCB.....	5-8
5-2-5 EMI PCB.....	5-9
<b>6. Wiring Diagram.....</b>	<b>6-1</b>
6-1 Indoor Unit.....	6-1
6-2 Outdoor Unit.....	6-2
<b>7. Reference Sheet.....</b>	<b>7-1</b>
7-1 Index for Model Name.....	7-1
7-1-1 Indoor Unit.....	7-1
7-1-2 Outdoor Unit.....	7-2
7-1-3 Panel.....	7-3
7-2 Refrigerating Cycle Diagram.....	7-4

---

# 1. Precautions

---

## 1-1 Precautions for the Service

---

- **Use the standard parts when replacing the electric parts.**
  - Confirm the model name, rated voltage, rated current of the electric parts.
- **When repairing the equipment, connection of the harness parts must be firm and solid.**
  - A loose connection may cause noise or other malfunction.
- **When assembling and disassembling the equipment while it is laid down, lay it on soft cloth.**
  - Otherwise it may scratch the back of the exterior of the product.
- **Remove dust or dirt completely from the housing block, wiring block and service parts during repair.**
  - This helps prevent the danger of fire caused by tracking or short circuit.
- **Fasten the valve caps of service valves and charging valves of outdoor unit as much as possible using adjustable wrenches.**
- **Check the status of the components' assembly after repair service.**
  - The status must be the same as before the repair service.

## 1-2 Precautions related to static electricity and PL

---

- **The PCB power supply block is susceptible to static electricity. Therefore, care must be taken during repair or measuring while the power is on.**
  - Wear insulation gloves for PCB repair or measuring.
- **Check whether the installation location is at least two meters away from other electronic products such as TV, video, or audio.**
  - Otherwise, the video quality might be degraded or noise might be generated.
- **Do not let end users repair the products themselves.**
  - Unauthorized disassembly might cause electric shock or fire.

## 1-3 Precautions related to product safety

---

- **Do not pull the power cord and do not touch the power plug or aux power switch with wet hands.**
  - It might cause electric shock or fire.
- **A damaged power line or power plug must be replaced to prevent danger.**
- **Do not bend the power cable with excessive force, and do not place a heavy weight on the case as it might damage the cable.**
  - It might cause electric shock or fire.
- **Do not use multiple electric outlets.**
  - This might cause electric shock or fire.
- **Connect the ground terminal when necessary.**
  - You must connect the ground terminal if you determine that there is a danger of electric leakage due to moisture or water.
- **Unplug the power cable or turn off the auxiliary power switch for electric part replacement and repair service.**
  - Otherwise it might cause electric shock.
- **Instruct end users to separate the batteries from the remote controllers and store them separately when the product is not used for long time.**
  - Otherwise leakage from the dry cell may cause problems with the remote controller.

## 1-4 Other precautions

---

- **The pipes should have no leaks during installation, and the compressor must be stopped before removing connecting pipes for pump down work. Operating the compressor while the service valve is open and coolant pipe is not properly connected may cause explosion or injury due to abnormal high pressure created inside the coolant cycle as the air can be absorbed through the pipe.**
- **Pump Down work procedure (When uninstalling the product)**
  - Turn on the air conditioner, select cooling operation, and run the compressor for more than three minutes.
  - Release the high pressure and low pressure valve caps.
  - Close the high pressure valve completely using an L-wrench
  - After about two minutes, close the low pressure valve completely.
  - Stop running the air conditioner.
  - Separate the connecting pipe.

## 2. Product Specifications

### 2-1 The Feature of Product

#### 2-1-1 Features

##### ■ What is four-direction cassette type air conditioner?

Stylish design and pleasant cooling/heating will provide a pleasant ambience.

Four-direction cassette with powerful three-dimensional cooling and heating from four directions offers gapless pleasant environment and has the right design for high class interior and will provide an extra-stylish look.

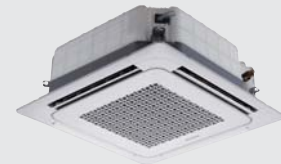

##### ■ Convenient and efficient installation

###### • Easy installation of ultra-lightweight indoor unit

A filter that obviates the need for replacement and/or maintenance up to 1,000~2,000 hours and retains its initial cleanness.

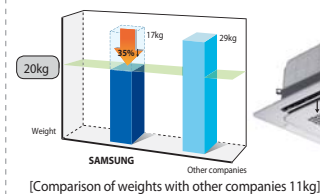

###### • Corner separable panel for simple leveling

The panel structure with four corners that can be separated enables convenient installation and service as only the required corner can be separated to adjust leveling when necessary.

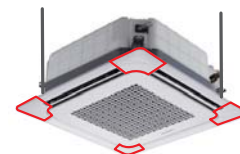

###### • Maintain pleasant temperature with fine temperature control with a resolution of 0.1°C

The equipment operates with minimum power to maintain the optimum temperature and it always maintains a pleasant room temperature in small temperature steps of 0.1°C that you may not be able to sense.

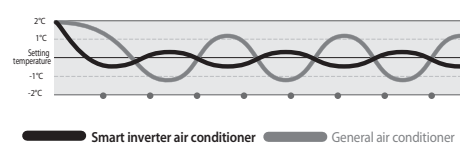

■ Rich and pleasant cooling/heating without gaps

• Superior heating performance even at -20°C

The equipment achieves a stable heating performance with the superior reliability of low temperature heating so that the indoor unit blows air of 40°C or higher in a cold winter when the outside temperature is below -20°C.



• Pleasant room with a check valve for preventing backflow

A check valve is installed to prevent condensed water drained from the indoor unit flowing back into the indoor unit for various reasons such as improper drain pipe installation or power cut, and indoor leak or bad smell by backflow is fundamentally blocked.

• Function to control optimum room temperature that reduces temperature variation

Room temperature sense condition can be set to 'Indoor + average of wired remote controller' to minimize the variation in temperature between the upper and lower levels generated by the effects of indoor air flow so that optimum room temperature will be maintained.



• Temperature setting (A): Indoor unit temperature setting  
• Temperature setting (B): Wired remote controller temperature setting

• Obtained Sterilization Treatment SF mark that removes the threat of mildew.

The equipment is very sanitary as an indoor heat exchange unit and filters are treated with world-recognized sterilization treatment technology to prevent the growth of mildew inside the unit.



• Patent registered in Korea, USA, Japan, and Italy  
(Patent number: Korea P-082555/ Italy 1294250/USA 594)



• Convenient control for high ceilings with wind velocity control function

When the unit is installed indoors, air flow can be set to reach the floor through the PCB option so that the unit can be installed on a ceiling with a height of 3.5 meters.

• Indoor PCB option setting

• ON: Increase wind velocity

• OFF: Decrease wind velocity

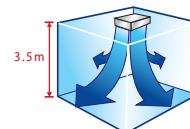

[When installing on a ceiling of 3m or higher]

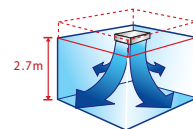

[When installing on a ceiling of 3m or lower]

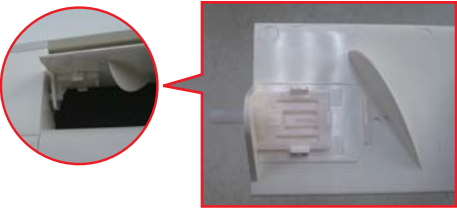

■ Convenience with more added details

<ul style="list-style-type: none"> <li>• <b>Easier than Ever to Clean the Blade</b> Other products require you to disassemble and remove the panel in order to clean the blade, but our product is designed so that the blade safely and easily detaches and re-attaches, enabling you to easily clean it.</li> </ul>	
---	--

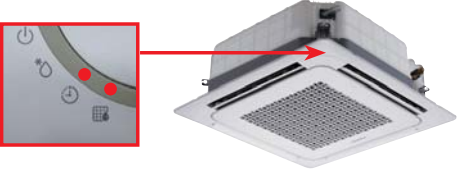
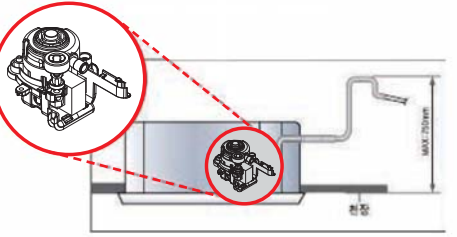
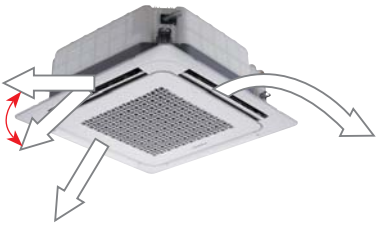

■ Rich and pleasant cooling/heating without gaps (cont.)

<ul style="list-style-type: none"> <li>• <b>Self diagnostic function of indoor unit to minimize inconvenience in case of malfunction</b> If the indoor unit malfunctions due to equipment failure during operation, the type of problem can be checked from the panel display, and the service time and inconvenience can be minimized by submitting a service request based on the information from the self diagnostics of indoor unit.</li> </ul>	
<ul style="list-style-type: none"> <li>• <b>Minimum installation cost by built-in high head drain pump</b> The high head pump is built into the indoor unit and the condensed water generated during the cooling operation will be drained to the outside. The pumping height can be up to 750mm so that drain pip installation can be easier and save time and cost of installation.</li> </ul>	
<ul style="list-style-type: none"> <li>• <b>Individual Blade Control</b> <ul style="list-style-type: none"> <li>- Capable of realizing optimal air current in accordance to customer preference and diverse structures located in different directions through individual control of each of the 4 blades.</li> <li>- Individual control can be realized through both cable and wireless remote control.</li> </ul> </li> </ul>	



## 2-2 Product Specifications

ITEM		Development Model			
		AC018JN4DCH AC018JXADCH	AC024JN4DCH AC024JXADCH	AC030JN4DCH AC030JXADCH	
IMAGE	INDOOR UNIT				
	OUTDOOR UNIT				
	REMOTE CONTROLLER				
Performance	Cooling [Btu/h]	18000	24000	30000	
	Heating [Btu/h]	20000	27000	32000	
Power Consumption	Cooling [W]	1540	2110	2890	
	Heating [W]	1600	2500	3110	
EER/COP	Cooling [Btu/hW]	11.71	11.41	10.41	
	Heating [Btu/hW]	12.51	10.81	10.31	
Voltage / Frequency		208~230V/60Hz	208~230V/60Hz	208~230V/60Hz	
Operating Current	Cooling [A]	7.1	9.8	13.4	
	Heating [A]	7.4	11.6	14.4	
Noise	Indoor Unit [dBA] (C/H)	42/42	45/45	47/47	
	Outdoor Unit [dBA] (C/H)	58/58	60/60	60/60	
Size	Net Dimension (WxDxH)	Indoor Unit [mm]	840*840*204	840*840*204	840*840*288
		Outdoor Unit [mm]	898*898*275	898*898*275	898*898*357
	Shipping Dimension (WxDxH)	Indoor Unit [mm]	880*310*638	940*330*998	940*330*998
		Outdoor Unit [mm]	1023*413*730	995*426*1096	995*426*1096
Weight	Net Weight	Indoor Unit [kg]	15.5	15.5	19
		Outdoor Unit [kg]	45	64.5	70
	Shipping Weight	Indoor Unit [kg]	19.5	19.5	24
		Outdoor Unit [kg]	48	69.5	74
Harness Specifications	Indoor Fan Motor		DB31-00578B	DB31-00578B	DB31-00577A
	Compressor		UG4T150LNBEQ	UG4T200LNFE4	UG8T300LNBJU
	Outdoor Fan Motor		DB31-00642A	DB31-00579A	DB31-00579A
Piping	High Pressure		4.1	4.1	4.1
	Low Pressure		1.4	1.4	1.4
PANEL		PC4NUSKFN			
Refrigerant Type		R410A			
Factory Charging [g]		1300	2100	2600	
Additional Refrigerant (for every 1m) [g]		10	10	22	
Basic Piping Length [m]		7.5	7.5	7.5	
Max. Piping Length [m]		30	50	50	
Max. Level Difference [m]		20	30	30	
Option Code		01406F-1950D8-27343B-370005 020000-100000-200000-300000 034745-103D49-200000-300002	01406F-1950D8-274750-370005 020000-100000-200000-300000 034042-10414C-200000-300002	01406F-1950E8-275A64-370045 020000-100000-200000-300000 033E39-103B45-200000-300002	

ITEM		Development Model			
		AC036JN4DCH AC036JXADCH	AC042JN4DCH AC042JXADCH	AC048JN4DCH AC048JXADCH	
IMAGE	INDOOR UNIT				
	OUTDOOR UNIT				
	REMOTE CONTROLLER				
Performance	Cooling [Btu/h]	36000	42000	48000	
	Heating [Btu/h]	40000	47000	53000	
Power Consumption	Cooling [W]	2980	4040	4950	
	Heating [W]	3480	4350	5050	
EER/COP	Cooling [Btu/hW]	12.11	10.41	9.71	
	Heating [Btu/hW]	11.51	10.81	10.51	
Voltage / Frequency		208~230V/60Hz	208~230V/60Hz	208~230V/60Hz	
Operating Current	Cooling [A]	13.8	18.7	22.9	
	Heating [A]	16.1	20.1	23.4	
Noise	Indoor Unit [dBA] (C/H)	50/50	51/51	51/51	
	Outdoor Unit [dBA] (C/H)	60/60	62/62	62/62	
Size	Net Dimension (WxDxH)	Indoor Unit [mm]	840*840*288	840*840*288	840*840*288
		Outdoor Unit [mm]	898*898*357	898*898*357	898*898*357
	Shipping Dimension (WxDxH)	Indoor Unit [mm]	940*330*1210	940*330*1210	940*330*1210
		Outdoor Unit [mm]	995*426*1388	995*426*1388	995*426*1388
Weight	Net Weight	Indoor Unit [kg]	19	19	19
		Outdoor Unit [kg]	88	88	88
	Shipping Weight	Indoor Unit [kg]	24	24	24
		Outdoor Unit [kg]	98	98	98
Harness Specifications	Indoor Fan Motor		DB31-00577A	DB31-00577A	DB31-00577A
	Compressor		UG5T450FUEJX	UG5T450FUEJX	UG5T450FUEJX
	Outdoor Fan Motor		DB31-00579A	DB31-00579A	DB31-00579A
Piping	High Pressure		4.1	4.1	4.1
	Low Pressure		1.4	1.4	1.4
PANEL		PC4NUSKFN			
Refrigerant Type		R410A			
Factory Charging [g]		2800	2800	2800	
Additional Refrigerant (for every 1m) [g]		33	33	33	
Basic Piping Length [m]		7.5	7.5	7.5	
Max. Piping Length [m]		75	75	75	
Max. Level Difference [m]		30	30	30	
Option Code		01406F-195439-276470-370045 020000-100000-200000-300000 03453F-102B35-200000-300002	01406F-19544A-277D8C-370045 020000-100000-200000-300000 034343-103940-200000-300002	01406F-19545B-278CA0-370045 020000-100000-200000-300000 034748-104444-200000-300002	

## 2-3 Specifications of optional items

### 2-3-1 Accessories







Item	Description	Code No.	Q'ty	Remark
	Ass'y drain hose	DB94-02719B	1	Essential Offer (Indoor Unit)
	Cable-tie	DB65-00191A	6	
	Seal-drain ass'y	DB62-05810A	1	
	Seal-drain ass'y	DB62-05810F	1	
	Seal-drain ass'y	DB62-05810G	1	
	Cap Drain	DB63-10355C	3	Essential Offer (Outdoor Unit)
	Drain Plug	DB67-00806A	1	
	Rubber Leg	DB73-20134A	4	
	BOLT-FLANGE	6011-003975	4	Essential Offer (Panel)
	ASSY-INSTALLATION MANUAL	DB68-03837A	1	
	CARD WARRNATY	DB68-01675A	1	

**Accessories (cont.)****■ Wireless remote controller (MR-EH00, MR-EC00)**







Item	Descriptions	Code-No.	Q'TY	Remark
	Wireless remote controller	DB93-14643F(MR-EH00) DB93-14643K(MR-EC00)	1	
	Batteries for remote controller (specification: AAA type)	4301-000121	2	
	Remote controller holder	DB61-06087A	1	Optional
	M4×16 screw	6002-000581	2	
	User's manual	DB68-04667A	1	

**Accessories (cont.)**

■ **Wired remote controller (MWR-WE10N) [Code No. : DB97-22234A]**

Item	Descriptions	Code-No.	Q'TY	Remark
	Wired remote controller	DB93-11251F	1	Optional
	Cable tie	DB65-10088B	2	
	Cable clamp	DB65-10074E	3	
	M4x16 Screw	6002-000474	5	
	User's manual	DB68-03732A	1	
	Installation guide	DB68-03716A	1	

**Accessories (cont.)****■ Central controller (MCM-A202DN) [Code No. : DB97-22237A]**

Item	Descriptions	Code-No.	Q'TY	Remark
	Central controller	DB93-03425Q	1	Optional
	Cable tie	DB65-10088B	2	
	Cable clamp	DB65-10074E	5	
	M4 X 16 Screw	6002-000474	7	
	User's manual	DB68-03736A	1	
	Installation guide	DB68-03721A	1	

### 2-3-2 Filter specifications

Item	Descriptions	Code-No.	Remark
	Dust filter	DB63-03158A	Basic/ Water wash

---

## 3. Disassembly and Reassembly



---



### ■ Necessary Tools



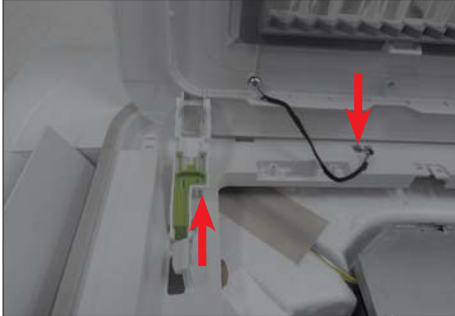
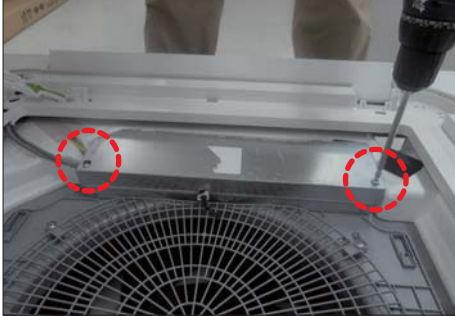
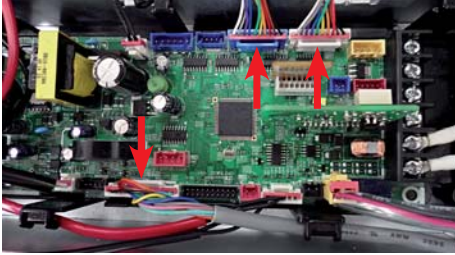

Item	Remarks
+SCREW DRIVER	
Adjustable Wrench (8mm, 10mm, 13mm)	
M6, M8 Hex Wrench	

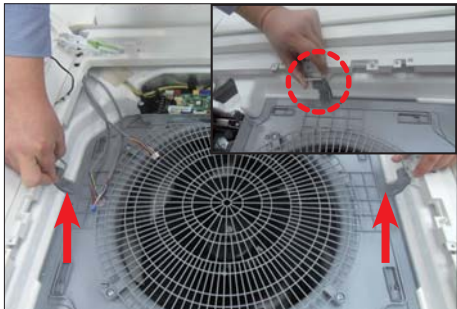
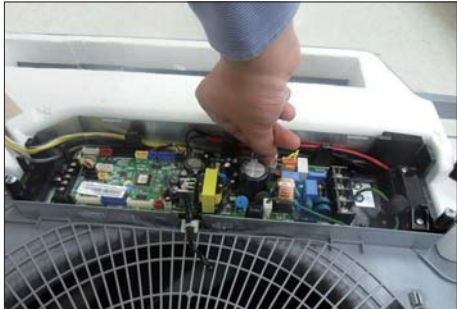

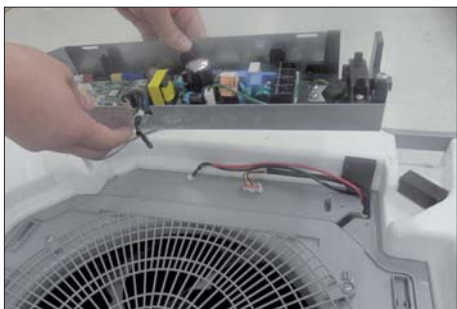

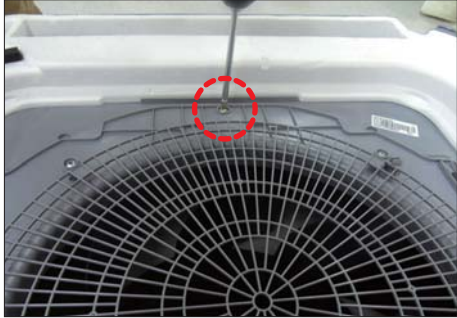

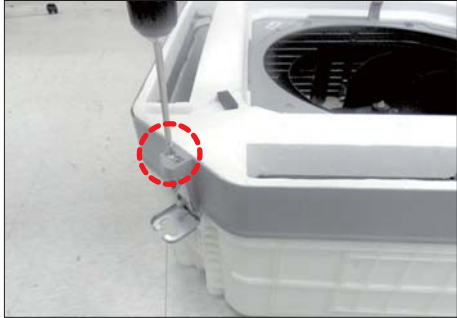

Disassembly and Reassembly  
**3-1 Indoor unit**

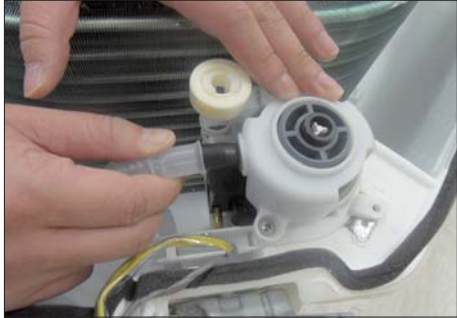
No	Parts	Procedure	Remark
1	Panel	<p>1) Push the handles on both sides of the Samsung logo towards the product's interior to open the Grille.</p> <p>2) Push up the green knob in the Open direction, and detach the white link from the panel. Detach the safety clip.</p> <p>3) Remove the 2 fixed screws to remove the Control-Box Cover. (Use +Screw Driver)</p> <p>4) Remove the Remocon-Receiver and Blade Connector Wire from the PBA. (3EA)</p> <p>5) Push the 4 panel corners and cover downwards to remove it.</p>	    

No	Parts	Procedure	Remark
		<p>6) Disassemble the bolts that are assembled with the indoor unit at the 4 panel corners.</p> <p>7) Press the Steel Hangers at both sides of the panel inwards, and rotate them 90 degrees to remove it from the indoor unit's Hock. Remove the panel from the indoor unit.</p>	 
2	Control-Box	<p>1) Disconnect the Connector Wire that is connected to the indoor unit's PBA from the PBA.</p> <p>2) Unscrew the 2 fixed screws on both sides of the Control Box, and disassemble the Control Box from the indoor unit. (Use +Screw Driver)</p>	  

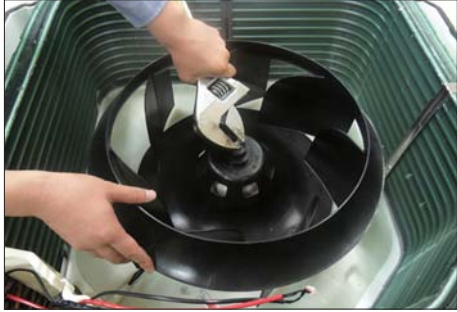
No	Parts	Procedure	Remark
3	Bell-Mouth	<p>1) Unscrew the screw fixed on the Bell-Mouth. (Use +Screw Driver)</p> <p>2) Push the Bell-Mouth in the direction opposite to where it's installed on the Control-Box to remove it.</p>	 
4	Drain Pan	<p>1) Unscrew the screws on the 4 corners of the indoor unit. (Use +Screw Driver)</p> <p>2) Remove the Drain Pan from the indoor unit.</p>	 

No	Parts	Procedure	Remark
5	Drain Pump & Hose	<p>1) Remove the 2 fixed screws and disconnect the white drainage hose from the Drain Pump. (Use +Screw Driver)</p> <p>2) Remove the 2 screws and take the Drain-Hose out from the indoor unit to disassemble the transparent Drain-Hose fixed on the side of the indoor unit. (Use +Screw Driver)</p>	  
6	Evap. Temperature Sensor	<p>1) Use your hand to remove the temperature sensor attached to the Evap Pipe along with the fixing clip.</p>	





No	Parts	Procedure	Remark
7	Fan & Motor	<ol style="list-style-type: none"> <li data-bbox="454 293 901 383">1) Turn the hexagonal nut attached to the top of the Fan counterclockwise to remove it. Take the Fan out of the Motor.</li> <li data-bbox="454 633 901 779">2) Turn the three hexagonal nuts on the Motor counterclockwise to remove the nuts. Take the Motor Wires attached to these three locations out with your hands prior to removing the Motor.</li> </ol>	  
8	Evaporator	<ol style="list-style-type: none"> <li data-bbox="454 1335 901 1424">1) Remove the screws of the 2 Steel Holder Evaps that are used to fix the Heat Exchanger, and then remove it. (Use +Screw Driver)</li> <li data-bbox="454 1686 901 1776">2) Remove the 2 fixing screws of the Partition Evap at the Heat Exchanger's In/Out Pipe. (Use +Screw Driver)</li> </ol>	 



No	Parts	Procedure	Remark
		<p data-bbox="456 293 900 376">3) Remove the screw of the Cover Pipe that is used to fix the In/Out Pipe. Remove the In/Out Pipe. (Use +Screw Driver)</p> <p data-bbox="456 645 831 701">4) Remove the Heat Exchanger from the indoor unit's cabinet.</p>	  

### 3-2 Outdoor Unit

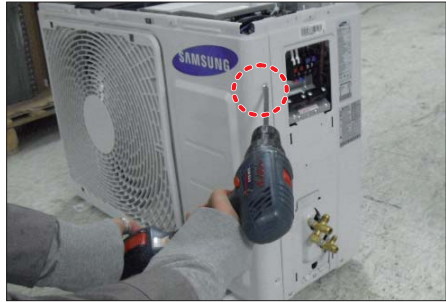

#### ■ AC018JXADCH

No	Parts	Procedure	Remark
1	common work	<p>1) loosen 1 pcs screw of cover control, and detach it.</p> <p>2) loosen 5 pcs screws on both right and left cabinet side edges and to detach the cover-top</p> <p>3) Loosen 7 screws fixed to disassemble cabi-front , and detach it.</p>	    



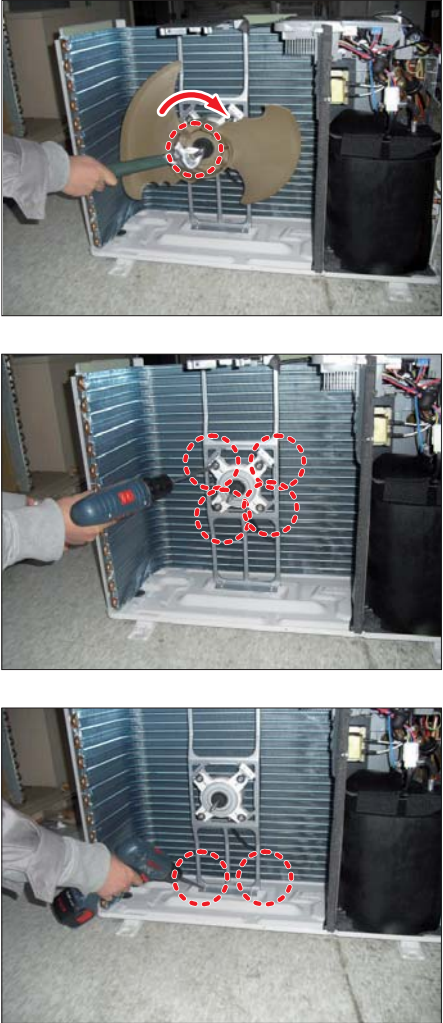





No	Parts	Procedure	Remark
2	fan&motor	<p>1) loosen 1 screw as indication and detached the fan.</p> <p>2) loosen 4 pcs motor screws and disconnect the wire between assy control out and motor.</p> <p>3) loosen 2 pcs bracket-motor screw and detach it.</p>	

No	Parts	Procedure	Remark
3	assy control out	<ol style="list-style-type: none"> <li>1) loosen fixing 1 screw from cover-control</li> <li>2) detach several connections from assy control out, take out assy control out.</li> </ol>	
4	Heat exchanger	<ol style="list-style-type: none"> <li>1) Release the refrigerant at first</li> <li>2) Loosen fixing screw on both side.</li> <li>3) disassemble the pipes in both inlet and outlet with welding torch.</li> <li>4) detach the heat exchanger.</li> </ol>	

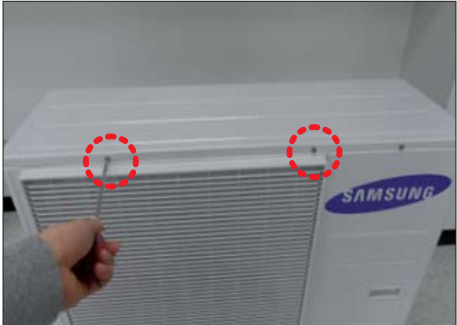



## ■ AC024JXADCH, AC030JXADCH

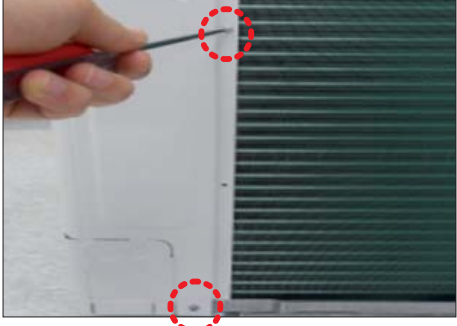
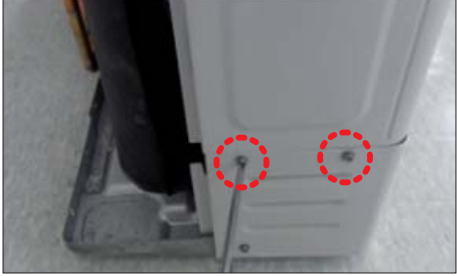

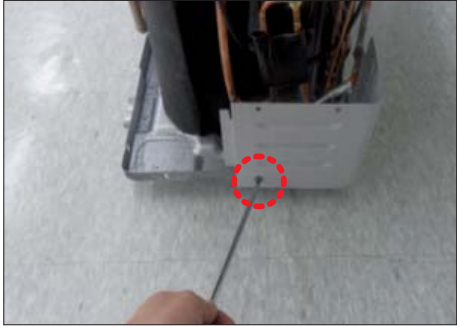
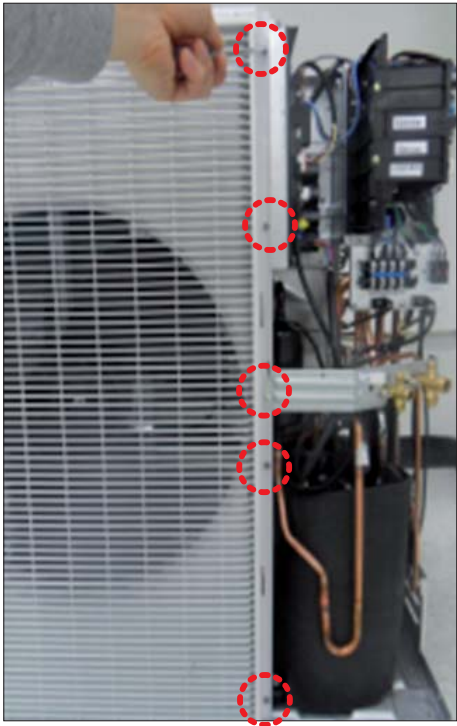
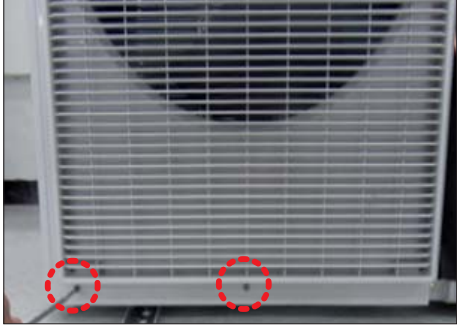
No	Parts	Procedure	Remark
1	Cabi Front RH	<p><b>⚠ You must turn off the Power before disassembly.</b></p> <p>1) Unscrew and remove two mounting screw in the Cabinet Front RH. (Use +Screw Driver)</p>	
2	Cabi Top	1) Unscrew and remove 9 screws on each side of the Cabinet-Top. (Use +Screw Driver)	
3	Cabi Install Front	1) Unscrew and remove 1 screw in the Cabinet-Install Front. (Use +Screw Driver)	

No	Parts	Procedure	Remark
4	Guard Cond	<p>1) Pull the sensor from Guard Cond.</p> <p>2) Unscrew and remove 4 screws in the Guard Cond. (Use +Screw Driver)</p>	 
5	Cabi Back RH	<p>1) Pull the sensor from Cabi Back RH.</p> <p>2) Unscrew and remove 4 screws on each side of the Cabinet Back RH. (Use +Screw Driver)</p>	  

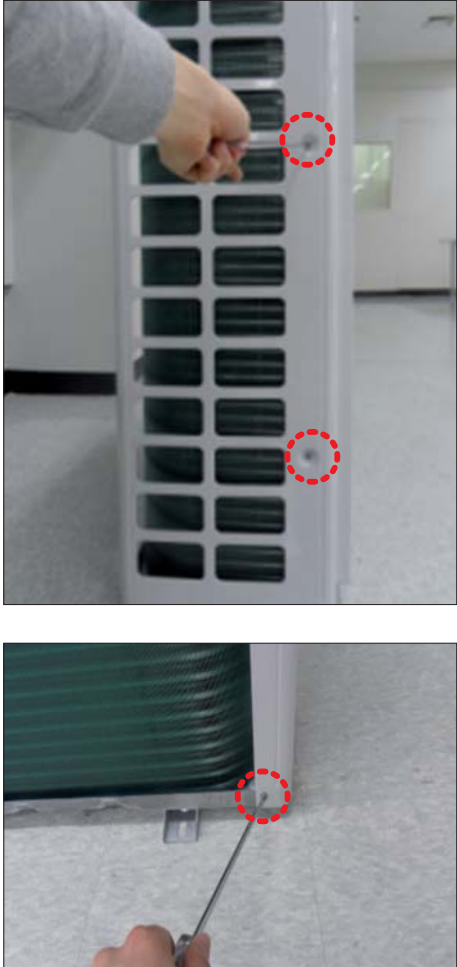
No	Parts	Procedure	Remark
6	Cabi Install Back	1) Unscrew and remove 1 screw in the Cabinet-Install Back. (Use +Screw Driver)	
7	Cabi Front LF	1) Unscrew and remove 10 screws in the Cabinet-Front LF. (Use +Screw Driver)	 



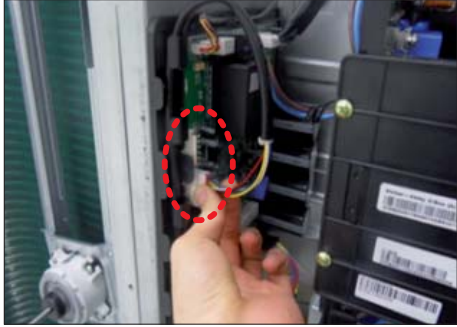

No	Parts	Procedure	Remark
			
8	Fan	<p>1) Turn 2 mounting nuts as shown in the picture and remove it. (Use Adjustable Wrench)</p>	

No	Parts	Procedure	Remark
9	Motor	<ol style="list-style-type: none"> <li>1) Separate the Fan Propeller.</li> <li>2) Unscrew and remove the 8 Motor mounting screws. (Use +Screw Driver)</li>   <li>3) Disconnect the Motor wire From Ass'y Control Out.</li> </ol>	 
10	Bracket Motor	<ol style="list-style-type: none"> <li>1) Unscrew and remove 2 mounting screws in Bracket Motor. (Use +Screw Driver)</li> </ol>	





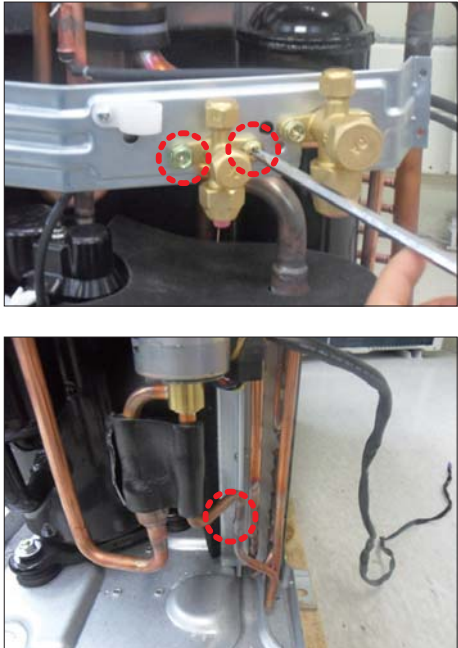



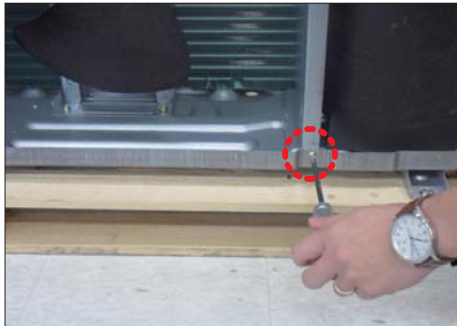
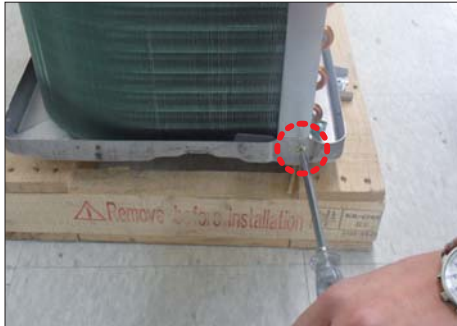
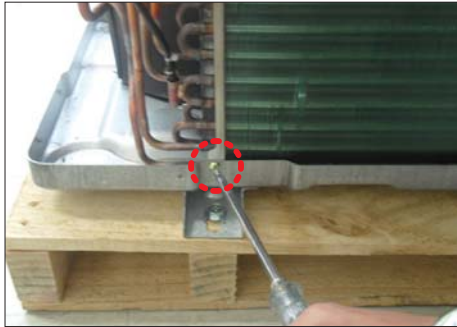

No	Parts	Procedure	Remark
13	Assy EEV Valve	1) Unscrew and remove 2 mounting screws in Service Valve. (Use +Screw Driver)  2) Separate the pipe from the Entrance/Exit using a welder.	
14	Compressor	1) Unscrew and remove 1 mounting nut in Cover Terminal. (Use Adjustable Wrench)  2) Separate the Compressor Felt Sound.	

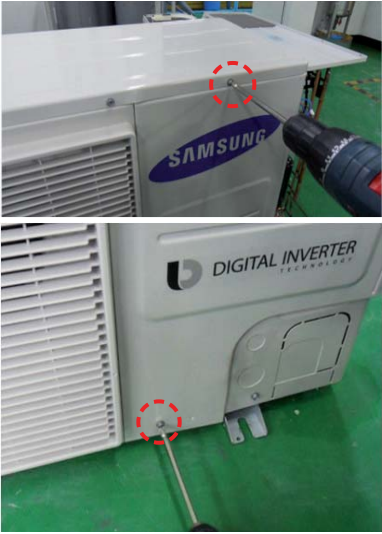
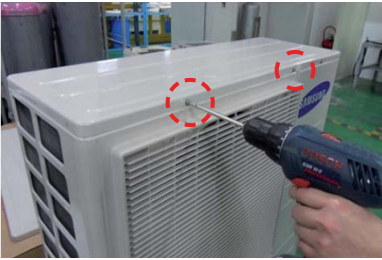
No	Parts	Procedure	Remark
		<p>3) As shown in the picture, unscrew and remove 3 mounting screws from the bottom. (Use Adjustable Wrench)</p>	
15	Cond Out	<p>1) Unscrew and remove 3 screws on each side of the Assy Cond Out. (Use +Screw Driver)</p> <p>2) Separate the Compressor Felt Sound.</p>	  



■ AC036JXADCH, AC042JXADCH, AC048JXADCH

No	Parts	Procedure	Remark
1	Cabi Front RH	<p>⚠ You must turn off the Power before disassembly.</p> <p>1) Unscrew and remove two mounting screw in the Cabinet Front RH. (Use +Screw Driver)</p>	
2	Cabi Top	<p>1) Unscrew and remove 9 screws on each side of the Cabinet-Top. (Use +Screw Driver)</p>	
3	Cabi Install Front	<p>1) Unscrew and remove 1 screw in the Cabinet-Install Front. (Use +Screw Driver)</p>	
4	Guard Cond	<p>1) Pull the sensor from Guard Cond.</p> <p>2) Unscrew and remove 4 screws in the Guard Cond. (Use +Screw Driver)</p>	

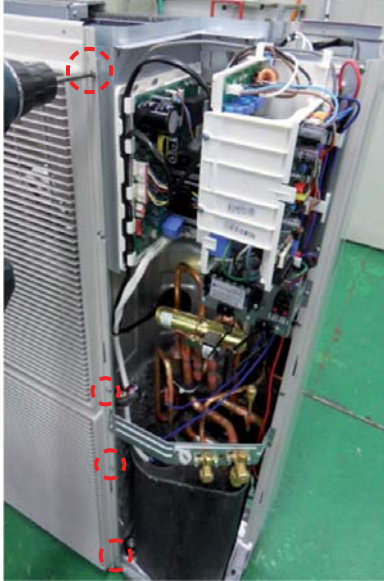
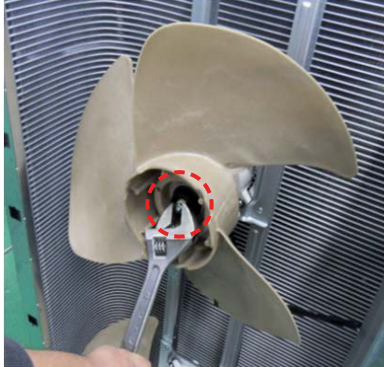

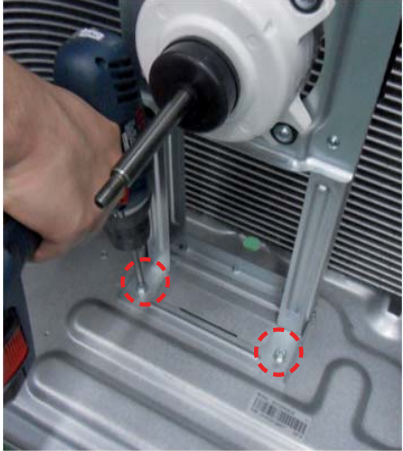
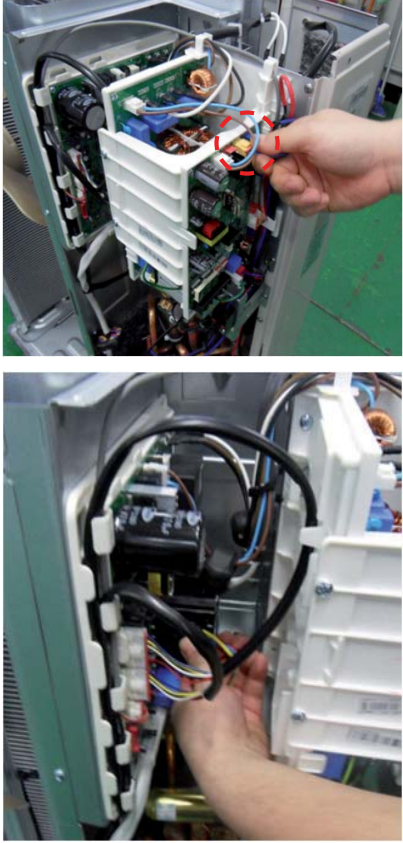
No	Parts	Procedure	Remark
5	Cabi Back RH	1) Pull the sensor from Cabi Back RH. 2) Unscrew and remove 4 screws on each side of the Cabinet Back RH. (Use +Screw Driver)	
6	Cabi Install Back	1) Unscrew and remove 1 screw in the Cabinet-Install Back. (Use +Screw Driver)	
7	Cabi Front LF	1) Unscrew and remove 10 screws in the Cabinet-Front LF. (Use +Screw Driver)	
8	Fan	1) Turn 2 mounting nuts as shown in the picture and remove it. (Use Adjustable Wrench)	

No	Parts	Procedure	Remark
9	Motor	1) Separate the Fan Propeller. 2) Unscrew and remove the 8 Motor mounting screws. (Use +Screw Driver) 3) Disconnect the Motor wire From Ass'y Control Out.	
10	Bracket Motor	1) Unscrew and remove 2 mounting screws in Bracket Motor. (Use +Screw Driver)	
11	Control Out	1) Disconnect 4 Connecters From Ass'y Control Out. 2) Unscrew and remove 1 mounting screw in Control Out. (Use +Screw Driver) 3) Separate Ass'y Control Out.	

No	Parts	Procedure	Remark
12	Assy 4way Valve	<p>1) Purge the Coolant first.</p> <p>2) Unscrew and remove 2 mounting screws in Service Valve. (Use +Screw Driver)</p> <p>3) Separate the pipe from the Entrance/Exit using a welder.</p> <p><b>⚠ When removing the compressor, Heat Exchanger, and Pipe, purge the Coolant inside the Compressor completely and remove the pipe with a welding flame.</b></p>	
13	Assy EEV Valve	<p>1) Unscrew and remove 2 mounting screws in Service Valve. (Use +Screw Driver)</p> <p>2) Separate the pipe from the Entrance/Exit using a welder.</p>	



## 4. Troubleshooting

### 4-1 Setting an indoor unit address and installation option

- ▶ Set the indoor unit address and installation option with remote controller option.

Set the each option separately since you cannot set the ADDRESS setting and indoor unit installation setting option at the same time. You need to set twice when setting indoor unit address and installation option.

#### 4-1-1 The procedure of setting option

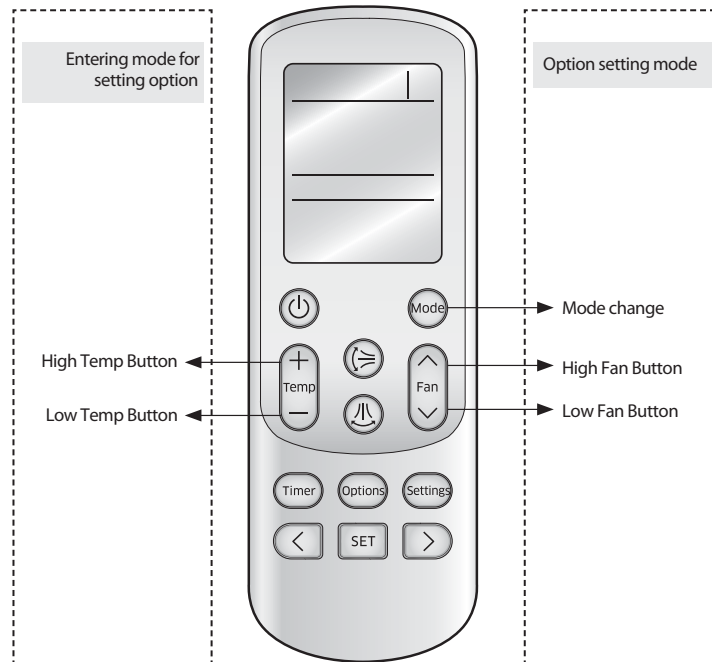

#### Step 1 Entering mode for option setting.

1. Remove batteries from the remote controller.
2. Insert the batteries while you press [+ Temperature] and [- Temperature] button at the same time.
3. Check if you have entered the option setting status. 

#### Step 2 Option setting procedure. (The option setting procedure is the same for other models.)

After entering the option setting status, select the option as listed below.





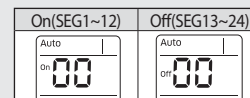

- Option setting is available from SEG1 to SEG 24.
- SEG1, SEG7, SEG13, SEG19 are not set as page option.
- Set the SEG2~SEG6, SEG8~SEG12 in the ON status and SEG14~18, SEG20~24 in the OFF status.



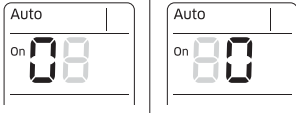

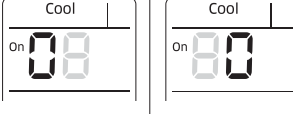

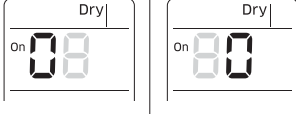
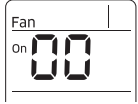
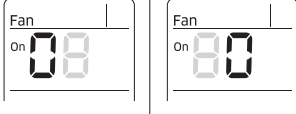
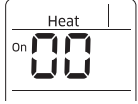
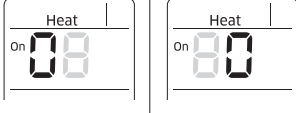
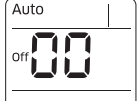
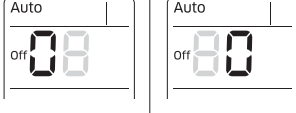



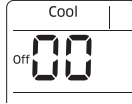



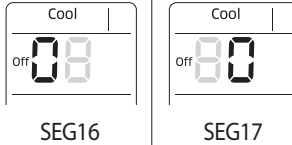

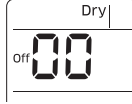



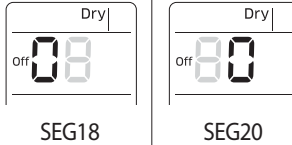

SEG1	SEG2	SEG3	SEG4	SEG5	SEG6	SEG7	SEG8	SEG9	SEG10	SEG11	SEG12
0	X	X	X	X	X	1	X	X	X	X	X
SEG13	SEG14	SEG15	SEG16	SEG17	SEG18	SEG19	SEG20	SEG21	SEG22	SEG23	SEG24
2	X	X	X	X	X	3	X	X	X	X	X

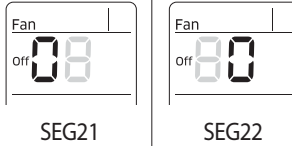

### 4-1-2 The procedure of setting option

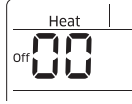
Option setting	Status
<p>1. Setting SEG2, SEG3 option                      Press Low Fan button(∨) to enter SEG2 value.                      Press High Fan button(∧) to enter SEG3 value.                      Each time you press the button, <math>\text{F} \rightarrow \text{F} \rightarrow \dots \text{E} \rightarrow \text{E}</math> will be selected in rotation .</p>	 <p style="text-align: center;">SEG2                      SEG3</p>
<p>2. Setting Cool mode                      (Mode) Press Mode button to be changed to Cool mode in the ON status .</p>	
<p>3. Setting SEG4, SEG5 option                      Press Low Fan button(∨) to enter SEG4 value.                      Press High Fan button(∧) to enter SEG5 value.                      Each time you press the button, <math>\text{F} \rightarrow \text{F} \rightarrow \dots \text{E} \rightarrow \text{E}</math> will be selected in rotation .</p>	 <p style="text-align: center;">SEG4                      SEG5</p>
<p>4. Setting Dry mode                      (Mode) Press Mode button to be changed to DRY mode in the ON status .</p>	
<p>5. Setting SEG6, SEG8 option                      Press Low Fan button(∨) to enter SEG6 value.                      Press High Fan button(∧) to enter SEG8 value.                      Each time you press the button, <math>\text{F} \rightarrow \text{F} \rightarrow \dots \text{E} \rightarrow \text{E}</math> will be selected in rotation .</p>	 <p style="text-align: center;">SEG6                      SEG8</p>
<p>6. Setting Fan mode                      (Mode) Press Mode button to be changed to FAN mode in the ON status .</p>	
<p>7. Setting SEG9, SEG10 option                      Press Low Fan button(∨) to enter SEG9 value.                      Press High Fan button(∧) to enter SEG10 value.                      Each time you press the button, <math>\text{F} \rightarrow \text{F} \rightarrow \dots \text{E} \rightarrow \text{E}</math> will be selected in rotation .</p>	 <p style="text-align: center;">SEG9                      SEG10</p>
<p>8. Setting Heat mode                      (Mode) Press Mode button to be changed to HEAT mode in the ON status .</p>	
<p>9. Setting SEG11, SEG12 option                      Press Low Fan button(∨) to enter SEG11 value.                      Press High Fan button(∧) to enter SEG12 value.                      Each time you press the button, <math>\text{F} \rightarrow \text{F} \rightarrow \dots \text{E} \rightarrow \text{E}</math> will be selected in rotation .</p>	 <p style="text-align: center;">SEG11                      SEG12</p>
<p>10. Setting Auto mode                      (Mode) Press Mode button to be changed to AUTO mode in the OFF status.</p>	
<p>11. Setting SEG14, SEG15 option                      Press Low Fan button(∨) to enter SEG14 value.                      Press High Fan button(∧) to enter SEG15 value.                      Each time you press the button, <math>\text{F} \rightarrow \text{F} \rightarrow \dots \text{E} \rightarrow \text{E}</math> will be selected in rotation.</p>	 <p style="text-align: center;">SEG14                      SEG15</p>

### The procedure of setting option (cont.)

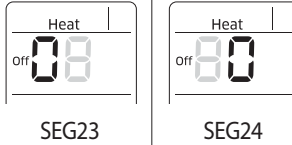
Option setting	Status
<p>12. Setting Cool mode</p> <p> Press Mode button to be change to Cool mode in the OFF status.</p>	
<p>13. Setting SEG16, SEG17 option</p> <p>Press Low Fan button(∨) to enter SEG16 value.</p> <p>Press High Fan button(∧) to enter SEG17 value.</p> <p>Each time you press the button,  →  → ...  →  will be selected in rotation.</p>	
<p>14. Setting Dry mode</p> <p> Press Mode button to be change to Dry mode in the OFF status.</p>	
<p>15. Setting SEG18, SEG20 option</p> <p>Press Low Fan button(∨) to enter SEG18 value.</p> <p>Press High Fan button(∧) to enter SEG20 value.</p> <p>Each time you press the button,  →  → ...  →  will be selected in rotation.</p>	
<p>16. Setting Fan mode</p> <p> Press Mode button to be change to Fan mode in the OFF status.</p>	
<p>17. Setting SEG21, SEG22 option</p> <p>Press Low Fan button(∨) to enter SEG21 value.</p> <p>Press High Fan button(∧) to enter SEG22 value.</p> <p>Each time you press the button,  →  → ...  →  will be selected in rotation.</p>	
<p>18. Setting Heat mode</p> <p> Press Mode button to be change to HEAT mode in the OFF status.</p>	
<p>19. Setting SEG23, SEG24 mode</p> <p>Press Low Fan button(∨) to enter SEG23 value.</p> <p>Press High Fan button(∧) to enter SEG24 value.</p> <p>Each time you press the button,  →  → ...  →  will be selected in rotation.</p>	

### Step 3. Check the option you have set

After setting option, press  button to check whether the option code you input is correct or not.

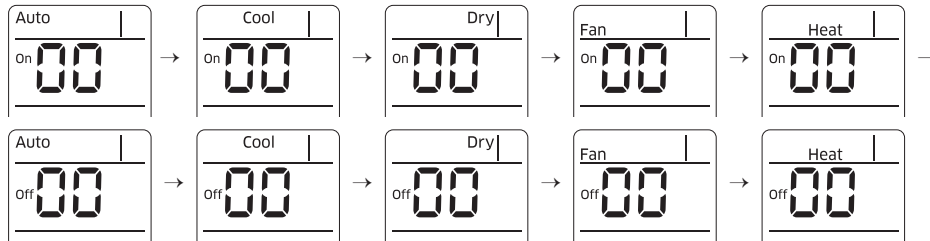

### Step 4. Input option

Press the operation button  with the direction of remote control for set.

For the correct option setting, you must input the option twice.

### Step 5. Check operation

- 1) Reset the indoor unit by pressing the RESET button of indoor unit or outdoor unit.
- 2) Take the batteries out of the remote controller and insert them again and then press the operation button.

### 4-1-3 Order for Setting Options (Wired Remote Controller)

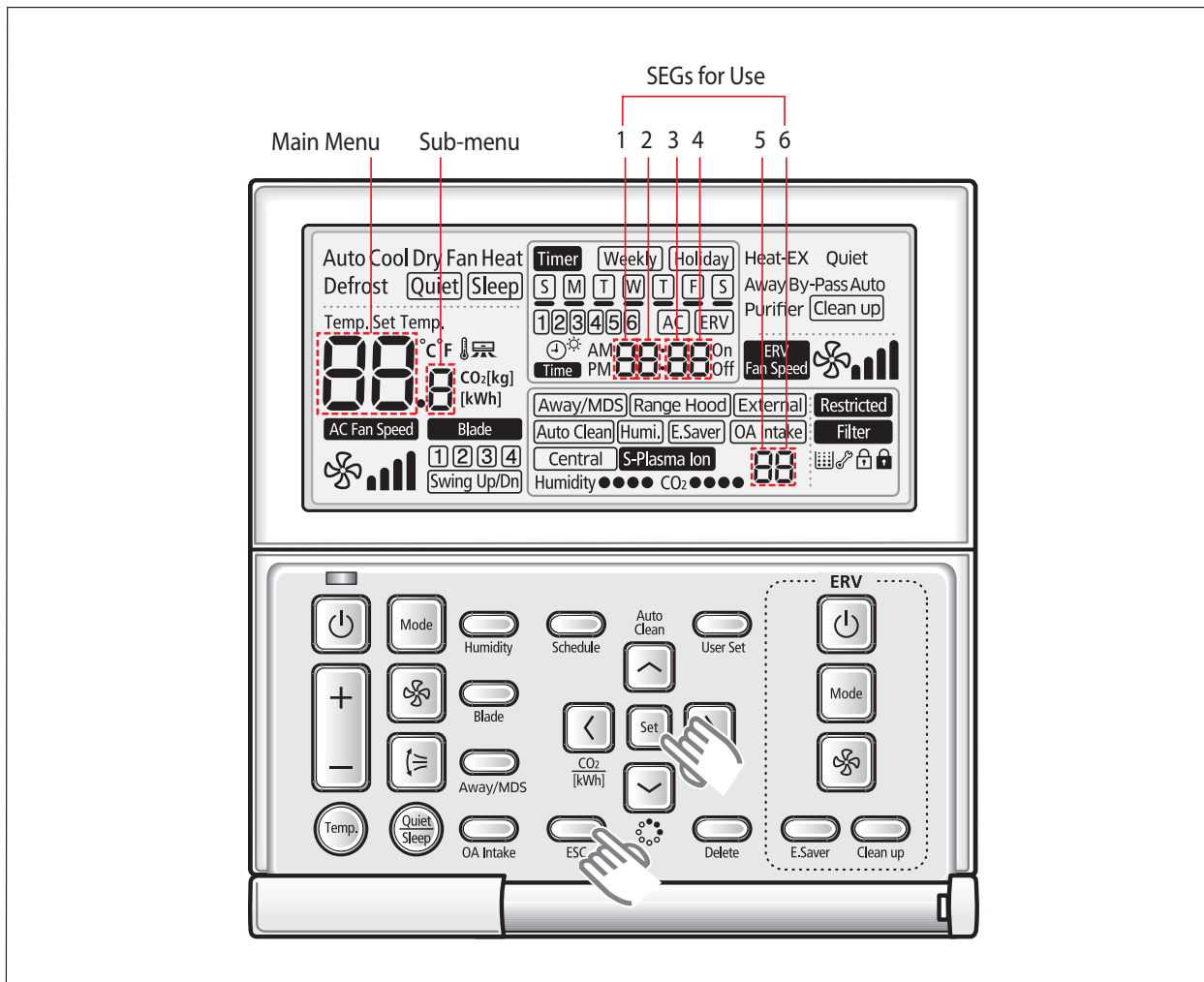

1. **If you want to use the various additional functions for your Wired Remote Controller, press the Set and Esc buttons at the same time for more than three seconds.**
  - ▶ You will enter the additional function settings, and the [main menu] will be displayed.
  
2. **Refer to the list of additional functions for your Wired Remote Controller on the next page, and select the desired menu.**
  - ▶ Using the [^]/[v] buttons, select a main menu number and press the [>] button to enter the sub-menu setting screen.
  - ▶ Using the [^]/[v] buttons, select a sub-menu number and press the [>] button to enter data setting screen.
  - ▶ When you enter the setting stage, the current setting will be displayed.
  - ▶ Refer to the chart for data settings.
  - ▶ Using the [^]/[v] buttons, select the settings. Press the [>] button to move to the next setting.
  - ▶ Press the **Set** button to save the settings and exit to the sub-menu setting screen.
  - ▶ Press the **Esc** button to exit to normal mode.



- While setting the data, you can use the [<]/[>] buttons to set the range of Data bit.
- While configuring the setting, press the **Esc** button to exit to the setting sub-menu without saving your changes.

#### 4-1-4 Setting an indoor unit installation option (Suitable for the condition of each installation location)

1. Check whether power is supplied or not.
  - When the indoor unit is not plugged in, there should be additional power supply in the indoor unit.
2. The panel(display) should be connected to an indoor unit to receive option.
3. Set the installation option according to the installation condition of an air conditioner.
  - The default setting of an indoor unit installation option is 02000-100000-200000-300000.
  - Individual control of a remote controller(SEG20) is the function that controls an indoor unit individually when there is more than one indoor unit.
4. Set the indoor unit option by wireless remote controller.

SEG1	SEG2	SEG3	SEG4	SEG5	SEG6
0	2	RESERVED	Exterior temperature sensor	Central control	FAN RPM
SEG7	SEG8	SEG9	SEG10	SEG11	SEG12
1	Drain pump	RESERVED	RESERVED	Indoor unit at heating stop	Master / Slave
SEG13	SEG14	SEG15	SEG16	SEG17	SEG18
2	External control	External control output	S-Plasma ion	Buzzer	Number of hours using filter
SEG19	SEG20	SEG21	SEG22	SEG23	SEG24
3	Individual control of a remote controller	Heating setting compensation	RESERVED	RESERVED	RESERVED

- ▶ 1WAY/2WAY/4WAY MODEL : Drain pump(SEG8) will be set to 'USE + 3minute delay' even if the drain pump is set to 0.
- ▶ 1 WAY/2WAY/4WAY,DUCT MODEL : Number of hours using filter(SEG18) will be set to '1000hour' even if the SEG18 is set to except for 2 or 6.
- ▶ If you input a number other than 0~4 of the individual control of the indoor unit(SEG20), the indoor is set as indoor 1.
- ▶ 4WAY MODEL : Even when the value of Heating setting compensation(SEG21) is set to '0', it will be recognized as '5°C'.

Option No. : 02XXXX-1XXXXX-2XXXXX-3XXXXX

Option	SEG1		SEG2		SEG3		SEG4		SEG5		SEG6	
Explanation	PAGE		MODE		RESERVED		Use of external temperature sensor		Use of central control		FAN RPM	
Remote Controller Display												
Indication and Details	Indication	Details	Indication	Details			Indication	Details	Indication	Details	0	nonuse
	0		2				0	Disuse	0	Disuse	2	High purity kit
							1	Use	1	Use	3	Noise reduction operation mode
Option	SEG7		SEG8		SEG9		SEG10		SEG11		SEG11	
Explanation	PAGE		Use of drain pump		RESERVED		RESERVED		Indoor unit at heating stop Electric modification diagram		Master / Slave	
Remote Controller Display												
Indication and Details	Indication	Details	Indication	Details					Indication	Details	Indication	Details
	1		0	Disuse			0	Default				
			1	Use			1	Noise reduction operation mode				
			2	Use + 3minute delay								
Option	SEG13		SEG14		SEG15		SEG16		SEG17		SEG18	
Explanation	PAGE		Use of external control		Setting the output of external control		S-Plasma ion		Buzzer control		Number of hours using filter	
Remote Controller Display												
Indication and Details	Indication	Details	Indication	Details	Indication	Details	Indication	Details	Indication	Details	Indication	Details
	2		0	Disuse	0	Thermo on	0	Disuse	0	Use of buzzer	2	1000 Hour
			1	ON/OFF Control OFF	1	Operation on	1	Use	1	Non use of buzzer	6	2000 Hour
			2	Control Window ON/OFF Control								
			3	Control Window ON/OFF Control								
Option	SEG19		SEG20		SEG21		SEG22		SEG23		SEG24	
Explanation	PAGE		Individual control of a remote controller		Heating setting compensation		RESERVED		RESERVED		RESERVED	
Remote Controller Display												
Indication and Details	Indication	Details	Indication	Details	Indication	Details						
	3		0 or 1	Indoor 1	0	Disuse						
			2	Indoor 2	1	2°C						
			3	Indoor 3	2	5°C						
			4	Indoor 4								

### 4-1-5 Changing a particular option

You can change each digit of set option.

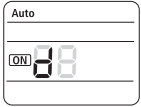
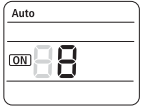
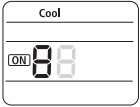
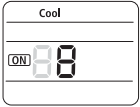
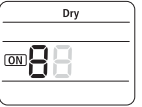
Option	SEG1		SEG2		SEG3		SEG4		SEG5		SEG6	
Explanation	PAGE		MODE		The option mode you want to change		The tens' digit of an option SEG you will change		The unit digit of an option SEG you will change		The changed value	
Remote Controller Display												
Indication and Details	Indication	Details	Indication	Details	Indication	Details	Indication	Details	Indication	Details	Indication	Details
	0		D		Option mode	0~F	Tens' digit of SEG	0~9	Unit digit of SEG	0~9	The changed value	0~F



CAUTION

- When changing a digit of an indoor unit address setting option, set the SEG3 as 'A'.
- When changing a digit of indoor unit installation option, set the SEG3 as '2'.

**Ex) When setting the 'buzzer control' into disuse status.**

Option	SEG1	SEG2	SEG3	SEG4	SEG5	SEG6
Explanation	PAGE	MODE	The option mode you want to change	The tens' digit of an option SEG you will change	The unit digit of an option SEG you will change	The changed value
Indication	0	D	2	1	7	1



### 4-1-6 Option code for each model

Model	SEG1	SEG2	SEG3	SEG4	SEG5	SEG6	SEG7	SEG8	SEG9	SEG10	SEG11	SEG12
Remocon display												
AC018JN4DCH	0	1	4	0	6	F	1	9	5	0	D	8
AC024JN4DCH	0	1	4	0	6	F	1	9	5	0	D	8
AC030JN4DCH	0	1	4	0	6	F	1	9	5	0	E	8
AC036JN4DCH	0	1	4	0	6	F	1	9	5	4	3	9
AC042JN4DCH	0	1	4	0	6	F	1	9	5	4	4	A
AC048JN4DCH	0	1	4	0	6	F	1	9	5	4	5	B
Model	SEG13	SEG14	SEG15	SEG16	SEG17	SEG18	SEG19	SEG20	SEG21	SEG22	SEG23	SEG24
Remocon display												
AC018JN4DCH	2	7	3	4	3	B	3	7	0	0	0	5
AC024JN4DCH	2	7	4	7	5	0	3	7	0	0	0	5
AC030JN4DCH	2	7	5	A	6	4	3	7	0	0	4	5
AC036JN4DCH	2	7	6	4	7	0	3	7	0	0	4	5
AC042JN4DCH	2	7	7	D	8	C	3	7	0	0	4	5
AC048JN4DCH	2	7	8	C	A	0	3	7	0	0	4	5

## 4-2 Items to check before diagnostics

### 4-2-1 Test run mode and View mode

#### ■ Display Option Key

KEY	Key Operation	7-segment Display
K1	Press once: Heating test run	H H BLANK BLANK
	Press twice: Defrost test run	H 3 BLANK BLANK
K2	Press once: Cooling test run	H 2 BLANK BLANK
K3	Reset	
K4	View mode	Refer to View mode display



#### ■ View mode display

※ Press the K4 switch to view the information on the system status as follows:

No. of Press	Display content	SEG1	SEG2	SEG3	SEG4	Unit
1	Order frequency	1	Three digits	Two digits	One digit	Hz
2	Current frequency	2	Three digits	Two digits	One digit	Hz
3	Number of indoor units	3	Three digits	Two digits	One digit	Unit
4	Out sensor	4	+/-	Two digits	One digit	°C
5	Discharge sensor	5	Three digits	Two digits	One digit	°C
6	Eva-Mid sensor	6	+/-	Two digits	One digit	°C
7	Cond sensor	7	+/-	Two digits	One digit	°C
8	Current	8	Two digits	One digit	First decimal	°C
9	Fan RPM	9	Four digits	Three digits	Two digits	rpm
10	Target discharge temperature	A	Three digits	Two digits	One digit	°C
11	EEV	B	Three digits	Two digits	One digit	step
12	Total indoor unit capacity	C	Two digits	One digit	First decimal	kW
13	Protection control	D	0: Cooling 1: Heating	Protection control 0: no protection control 1: freezing 2: non-stop defrosting 3: overload 4: discharge 5: under-current	Frequency state 0: Normal 1: Hold 2: Down 3: Up_limit 4: Down_limit	-
14	Heatproof plate temperature	E	Three digits	Two digits	One digit	-
15	S/W check	F	-	-	-	-

Ver.1 (Long Press once)	Main MICOM version	Year (Hex)	Month (Hex)	Date (Two digits)	Date (One digit)
Ver.2 (Short press once after Ver.1)	Inverter MICOM version	Year (Hex)	Month (Hex)	Date (Two digits)	Date (One digit)
Ver.3 (Short press once after Ver.2)	E2P version	Year (Hex)	Month (Hex)	Date (Two digits)	Date (One digit)

※ Press the K4 button long (Main MICOM version) → Press once more shortly → Press shortly one more time (E2P version)

## Test run mode and view mode (Continued)

### ■ DIP Switch Options

	ON	OFF																
K5	Set an auto address.	Set a manual address.																
K6	Snowdrift prevention control not used.	Snowdrift prevention control used.																
K7	<table border="1"> <thead> <tr> <th>K7</th> <th>K8</th> <th></th> </tr> </thead> <tbody> <tr> <td>ON</td> <td>ON</td> <td>Silent control not used</td> </tr> <tr> <td>ON</td> <td>OFF</td> <td>Silent control used Step_1</td> </tr> <tr> <td>OFF</td> <td>ON</td> <td>Silent control used Step_2</td> </tr> <tr> <td>OFF</td> <td>OFF</td> <td>Silent control used Step_3</td> </tr> </tbody> </table>			K7	K8		ON	ON	Silent control not used	ON	OFF	Silent control used Step_1	OFF	ON	Silent control used Step_2	OFF	OFF	Silent control used Step_3
K7	K8																	
ON	ON	Silent control not used																
ON	OFF	Silent control used Step_1																
OFF	ON	Silent control used Step_2																
OFF	OFF	Silent control used Step_3																
K8																		
K9	Auto silent mode	Manual silent mode																

### 4-2-2 Eco Mode [Power Saving Mode]

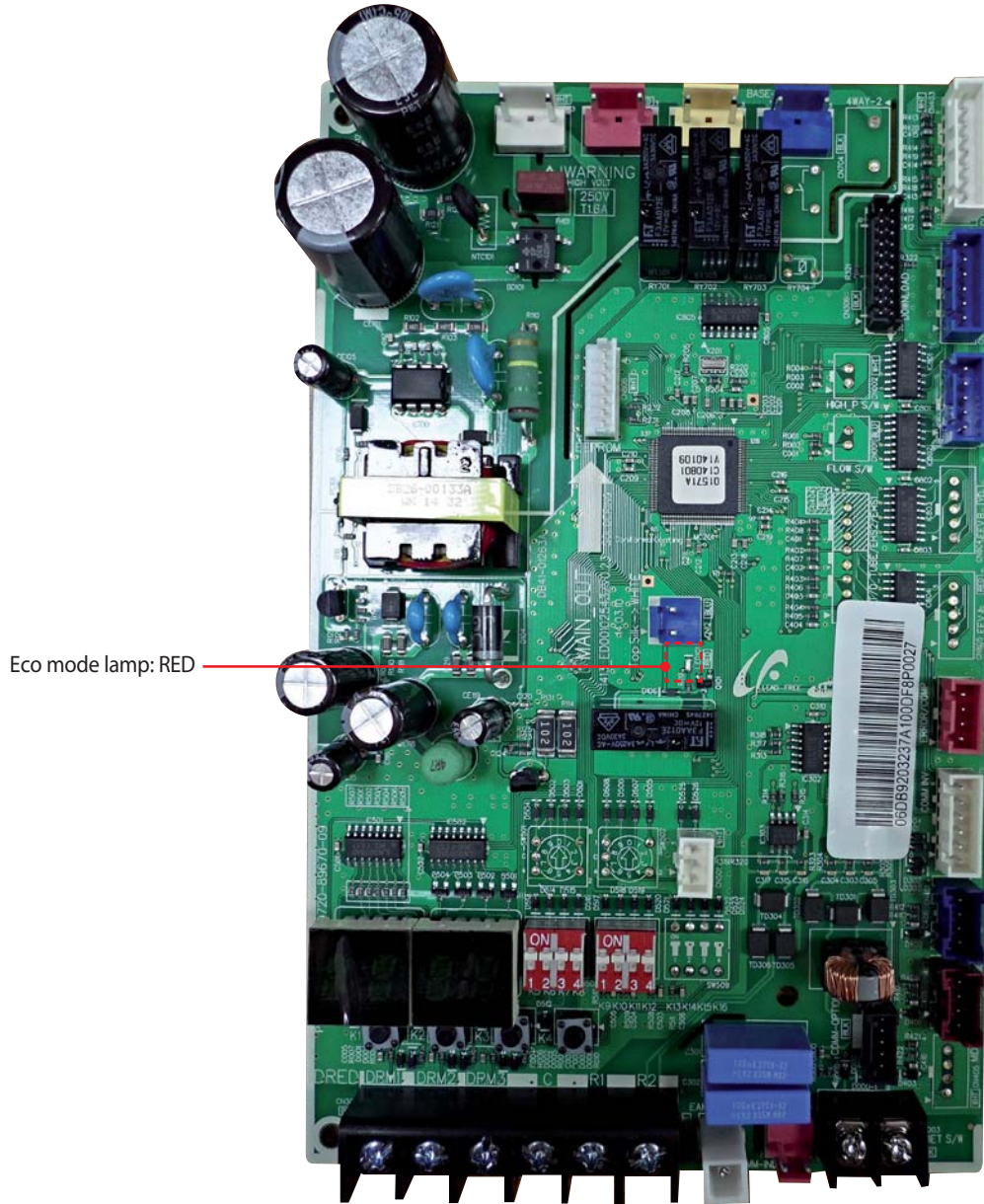

Mode	Display				Eco Mode Lamp
	Segment 1	Segment 2	Segment 3	Segment 4	
Eco Mode	BLANK	BLANK	BLANK	BLANK	On
Eco Mode Exit	Press K3 to go out from the eco mode. At the driving signal or test run (cooling/heating) of the user, the mode is released.				Off

### 4-2-3 Four directions cassette type

Error Mode				Cause	Measures	Product operation with error			Diagnosis method
Operation	Defrost	Timer	Filter			Outdoor heat exchanger compressor	Outdoor heat exchanger fan	Indoor heat exchanger fan	
●	X	X	X	Power reset	-	operation-off	operation-off	operation-off	-
X	●	X	X	Error of room temperature sensor in the indoor unit (Open/Short)	<ul style="list-style-type: none"> <li>• Check indoor temperature sensor connection.</li> <li>• Check indoor temperature sensor's resistance value to see if it's short/open.</li> </ul>	operation-off	operation-off	operation-off	-
●	●	X	X	Error of heat exchanger IN/OUT sensor in the indoor unit (Open/Short)	<ul style="list-style-type: none"> <li>• Check EVA IN/OUT sensor connection.</li> <li>• Check EVA IN/OUT sensor's resistance value to see if it's short/open.</li> </ul>	operation-off	operation-off	operation-off	-
X	X	●	X	Error of fan motor in the indoor unit	<ul style="list-style-type: none"> <li>• Check the connection of motor connector</li> <li>• Check the speed of the motor fan</li> </ul>	operation-off	operation-off	operation-off	-
●	X	●	X	Error of the outdoor temperature sensor Error of the condenser temperature sensor Error of the discharge temperature sensor	<ul style="list-style-type: none"> <li>• Check indoor temperature sensor connection.</li> <li>• Check indoor temperature sensor's resistance value to see if it's short/open.</li> </ul>	operation-off	operation-off	operation-off	-
X	●	●	X	No communication for 2 minutes between indoor and outdoor unit (communication error for more than 2 minutes)	<ul style="list-style-type: none"> <li>• Check connection between indoor and outdoor heat exchangers' communication cables</li> </ul>	operation-off	operation-off	operation-off	-
X	●	●	●	Error of outdoor unit	<ul style="list-style-type: none"> <li>• Check error occurred with outdoor heat exchanger.</li> <li>• TERMINAL Block thermal FUSE error.(OPEN)</li> </ul>	operation-off	operation-off	operation-off	-
X	X	●	●	Detection of the float switch	<ul style="list-style-type: none"> <li>• Check float switch connection.</li> <li>• Check whether the drain has been filled with water.</li> </ul>	operation-off	operation-off	operation-off	-
●	●	●	●	EEPROM error EEPROM option error	<ul style="list-style-type: none"> <li>• Check if there is damage with EEPROM component.</li> <li>• Check the indoor model to set the options.</li> <li>• Inspection for match between indoor and outdoor machine models</li> </ul>	operation-off	operation-off	operation-off	-
●	X	●	●	Outdoor valve clogging error.	<ul style="list-style-type: none"> <li>• High pressure check valve clogging.</li> </ul>	operation-off	operation-off	operation-off	-

○ : On   ● : Blink   X : Off

### 4-2-4 Wired remote controller

- If an error occurs, (  ) icon will be displayed on the wired remote controller.
- Press the Test button to see the error code.

Error mode	Contents	Measure	Product operation in error condition	Error type
			Outdoor unit/Compressor/Indoor unit	
101	Indoor unit communication error	Check the communication cable of indoor unit. Check the DC output voltage at the communication terminal.	Operation Off	Communication error
108	Duplicated address setting error	Check address setting of Indoor units.	Operation Off	Communication error
109	No response error address from indoor unit	Check indoor unit's quantity setting in outdoor unit. Check electrical connection and setting.	Operation Off	Communication error
121	Indoor temperature sensor (open/short error)	Check indoor unit room temperature sensor. Check indoor unit PCB connector CN41. (White)	Operation Off	Indoor sensor error
122	Indoor unit Eva In sensor (Open/Short)	Check indoor unit pipe sensor. Check indoor PCB connector CN41.(White)	Operation Off	Indoor sensor error
153	Indoor floating switch secondary detection	Check indoor unit float sensor. Check indoor PCB connector CN5. (black)	Operation Off	Self diagnostic error
202	Indoor/outdoor communication error (1 min)	Check the communication connection between indoor and outdoor units. Check the power line and communication cable connection status	Operation Off	Communication error
203	Communication error between indoor/outdoor INV↔MAIN MICOM (1 min)	Check MAIN MICOM . Check INVERTER MICOM.	-	Communication error
221	Outdoor temperature sensor error	Check sensor connection status. Check sensor location. Check sensor resistance.	Operation Off	Outdoor sensor error
231	COND temperature sensor error	Check sensor connection status. Check sensor location. Check sensor resistance.	Operation Off	Outdoor sensor error
251	[Inverter] Emission temperature sensor error	Check sensor connection status. Check sensor location. Check sensor resistance.	Operation Off	Outdoor sensor error
403	Detection of Indoor Freezing (when Comp. Stops)	Check whether the indoor unit air intake is blocked. Check the operation of the indoor fan.	Operation Off	Outdoor unit protection control error
404	Protection of Outdoor Overload (when Comp. Stops)	Check sensor connection status. Check sensor location. Check sensor resistance.	Operation Off	Outdoor unit protection control error
416	Emission temperature excessively high	No error. (DISCHARGE temperature control)	-	Outdoor unit protection control error
422	High pressure blockage error (Refrigerant completely Leakage error)	Check whether the outdoor unit service valve is open. Check the connection of the pipes. Check the operation of the EEV. Check for refrigerant leakage. (Completely leakage).	Operation Off	Self diagnostic error
440	Heating operation blocked	Check the operation setting state. Check temperature sensor.	Operation Off	Self diagnostic error
441	Cooling operation blocked	Check the operation setting state . Check temperature senso.	Operation Off	Self diagnostic error
458	Outdoor fan 1 error	Check input power connection status. Check the connection status between the motor and outdoor unit PCB. Check indoor/outdoor fuse.	Operation Off	Self diagnostic error
461	[Inverter] Compressor startup error	Check the compressor connection status. Check the resistance between difference phases of the compressor.	Operation Off	Outdoor unit protection control error
462	[Inverter] Total current error/ PFC over current error	Check the input power Check the coolant charging status Check the normal operation of outdoor fan	Operation Off	Outdoor unit protection control error

**Wired remote controller (cont.)**

Error mode	Contents	Measure	Product operation in error condition	Error type
			Outdoor unit/ Compressor/Indoor unit	
463	OLP Overheat and Comp. Stop	Reconfirm the opening of the service valve. Check for leaks from the connection part of the pipe and product or from the pipe joint. Change the outdoor unit location and direction. Refill the coolant after checking the leaking part. Reinstall the outdoor unit set.	Operation Off	Outdoor unit protection control error
464	[Inverter] IPM over current error	Check coolant charging Check the compressor connection status and normal operation Check the obstacles around the indoor and outdoor units Check whether the outdoor unit service valve is open Check whether the indoor/outdoor installation pipe/wiring are correct	Operation Off	Outdoor unit protection control error
465	Compressor V limit error	Check the compressor connection status Check the resistance between difference phases of the compressor	Operation Off	Outdoor unit protection control error
466	DC LINK over/low voltage error	Check input power Check AC power connection	Restart in 3 minutes	Outdoor unit protection control error
467	[Inverter] Compressor rotation error	Check the compressor connection status Check the resistance between difference phases of the compressor	Operation Off	Outdoor unit protection control error
468	[Inverter] Current sensor error	Check EEPROM DATA Check the normal operation of PCB	Operation Off	Outdoor unit protection control error
469	[Inverter] DC LINK voltage sensor error	Check the input power connection Check the status of RY21 and R200 in the INVERTER PCB	Operation Off	Outdoor unit protection control error
470	EEPROM Read/Write error	-	Operation Off	Outdoor unit protection control error
471	[Inverter] OTP error	Check EEPROM DATA Check the normal operation of PCB	Operation Off	Outdoor unit protection control error
472	AC ZERO CROSSING SIGNAL OUT error	Check the input power status	Operation Off	Outdoor unit protection control error
473	Compressor LOCK error	Check the compressor connection status Check the resistance between difference phases of the compressor	Operation Off	Outdoor unit protection control error
475	Outdoor fan 2 error	Check the input power connection status Check the connection status of the motor and the outdoor unit PCB Check the indoor/outdoor unit fuse	Operation Off	Self diagnostic error
500	IPM Overheat Error for Outdoor Unit Inverter Comp.	Change the location of the outdoor unit if the temperature is abnormally high when the heatproof plate is checked. Reconnect the screws. Replace the outdoor unit fan. Replace the PBA of the outdoor unit.	Operation Off	Outdoor unit protection control error
554	Gas leak error	Check the coolant charging status Check the indoor EVA sensor Check if the outdoor unit service value is open Check that the indoor/outdoor installation pipe/wiring are correct	Operation Off	Self diagnostic error

**Wired remote controller (cont.)**

Error mode	Contents	Measure	Product operation in error condition	Error type
			Outdoor unit/ Compressor/Indoor unit	
<b>556</b>	Capacities not matched	Check the option code of the indoor unit	Operation Off	Outdoor unit protection control error
<b>601</b>	Communication error between the indoor unit and wired remote controller	Check the connection wire between the indoor unit and the wired remote controller	Normal operation	Wired remote controller error
<b>602</b>	Communication error between the Master and Slave wired remote controllers	Check the option switch for defining the Master and Slave (only one Master and one Slave can exist)	Normal operation	Wired remote controller error
<b>606</b>	COM1/COM2 cross installation error	Check that wired remote controller is connected to the COM2 terminal of the indoor unit	Normal operation	Wired remote controller error
<b>8E8</b>	Wired remote controller COM2 option setting error	Check that Com1, Com2 setting DIP switch is set to Com2	Normal operation	Wired remote controller error



## 4-3 Troubleshooting by symptoms

### 4-3-1 Indoor temperature sensor (open/short)

<b>Indoor unit display</b>	X (Operation) ● (Defrost) X (Timer) X (Filter)
<b>Symptom</b>	In case of open or short circuit of indoor temperature sensor
<b>Failure</b>	Short or leakage of the corresponding sensor

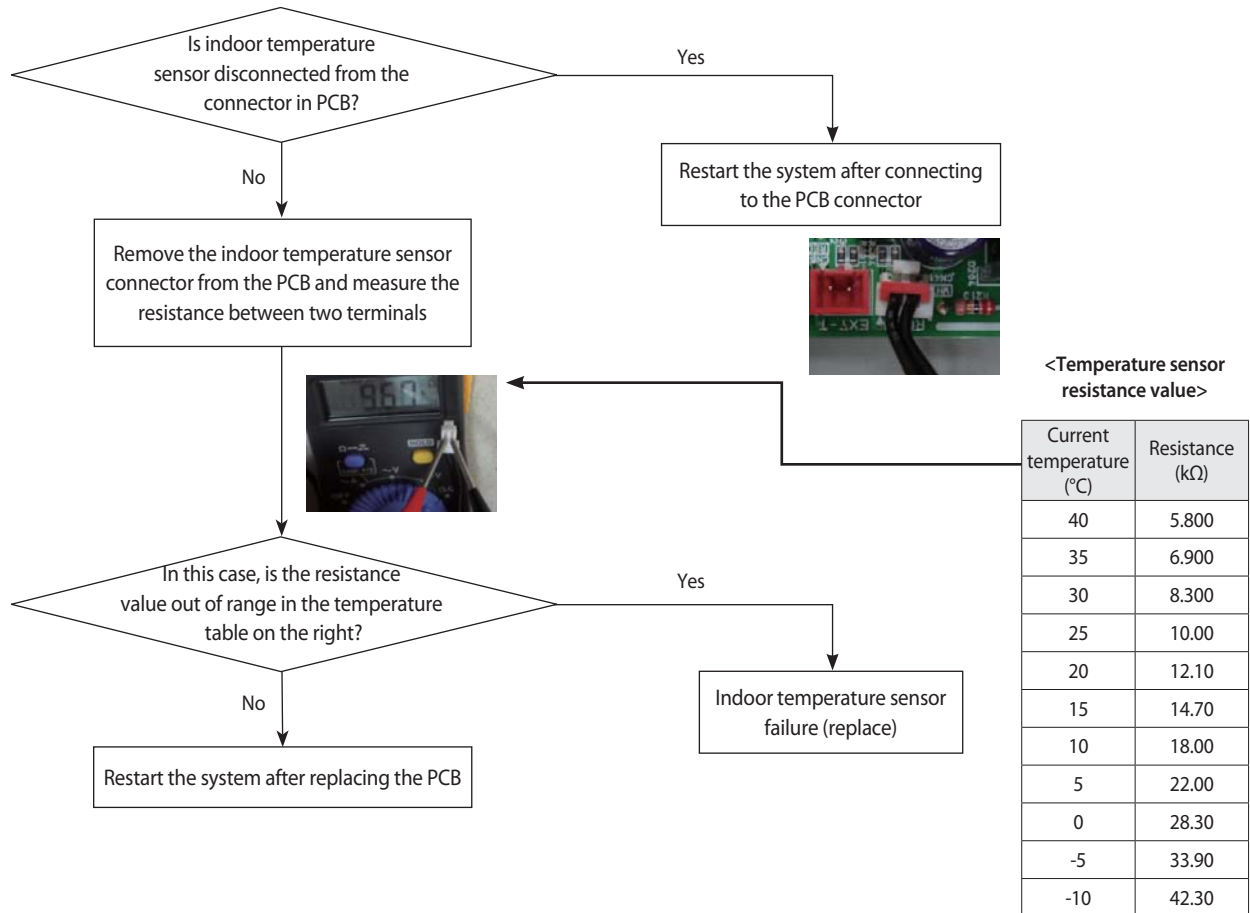

### 4-3-2 Indoor heat exchanger temperature sensor (open/short)

<b>Indoor unit display</b>	● (Operation) ● (Defrost) X (Timer) X (Filter)
<b>Symptom</b>	Short or open circuit of indoor heat exchanger temperature sensor
<b>Failure</b>	Short or open circuit in the corresponding sensor

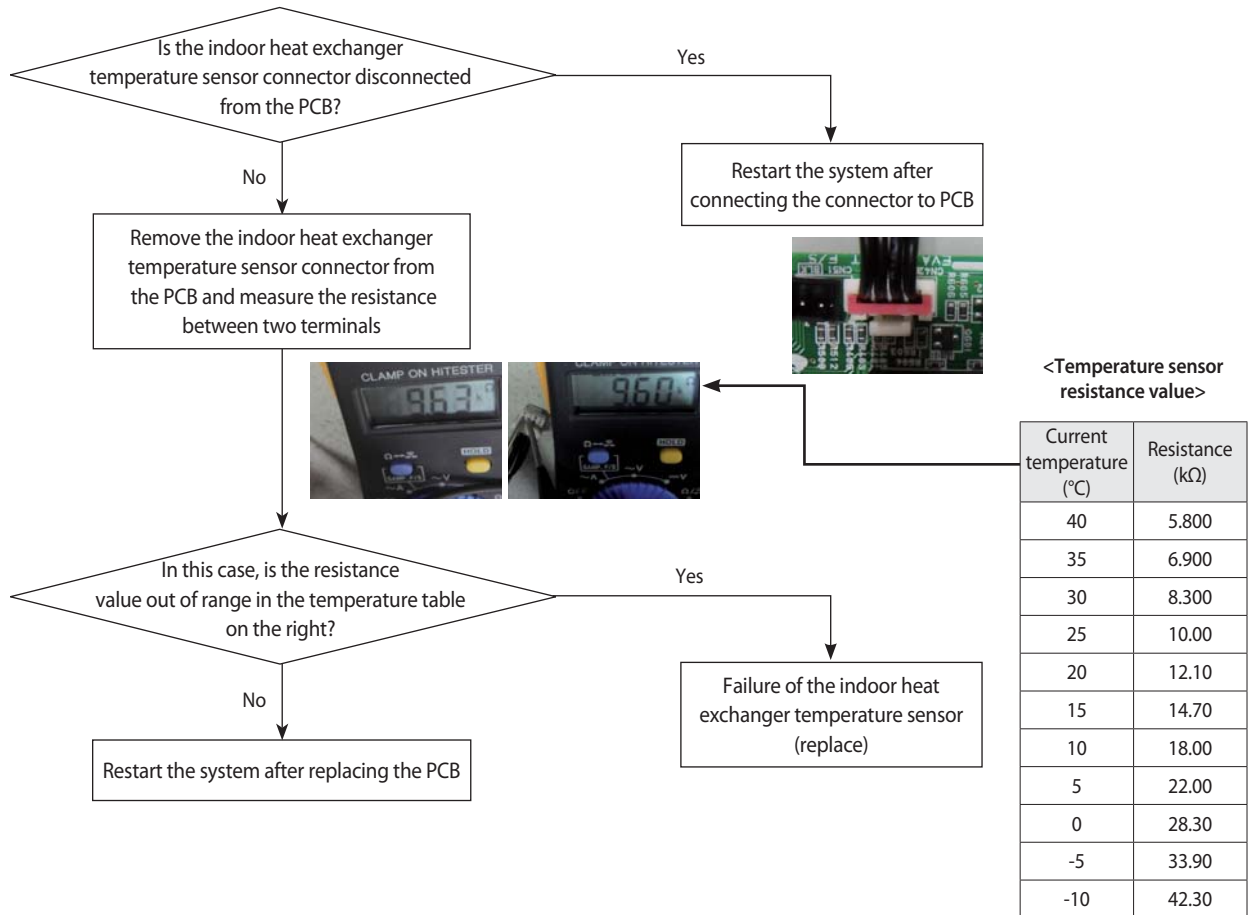

### 4-3-3 Indoor FAN error

<b>Indoor unit display</b>	X (Operation) X (Defrost) ● (Timer) X (Filter)
<b>Symptom</b>	Indoor unit fan does not run /Runs at excessive high speed and stops.
<b>Failure</b>	. Motor connector break away . Indoor unit FAN does not run : Defective motor or PBA

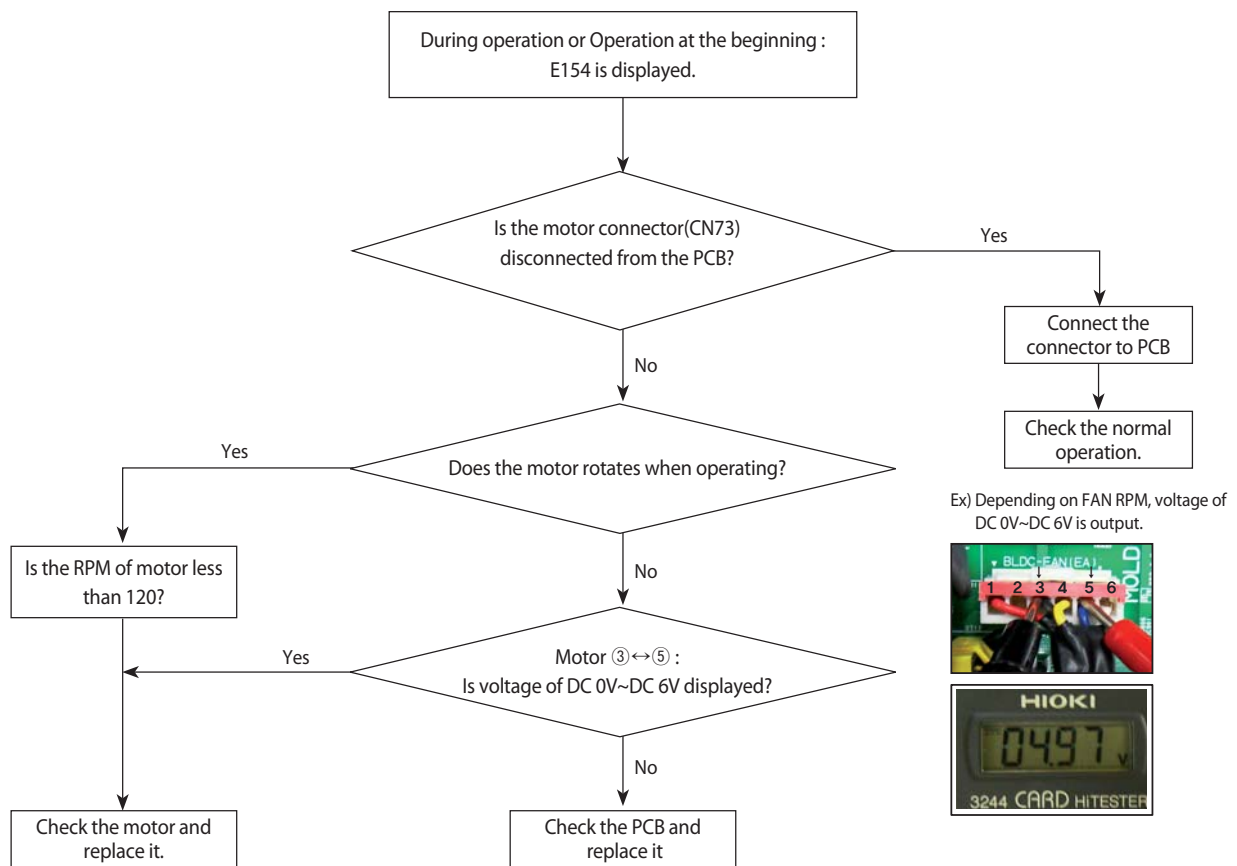

### 4-3-4 Communication error after finishing Tracking

<b>Indoor unit display</b>	X (Operation) ● (Defrost) ● (Timer) X (Filter)
<b>Symptom</b>	Communication error between the indoor and outdoor unit for two minutes
<b>Failure</b>	Communication error between the indoor unit and outdoor unit

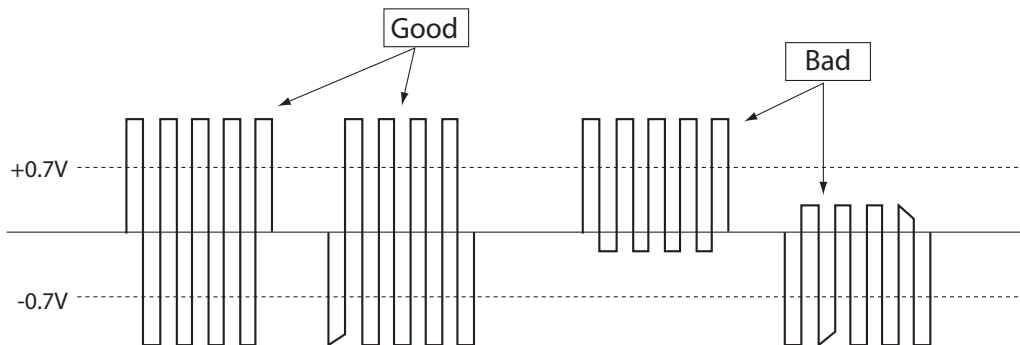
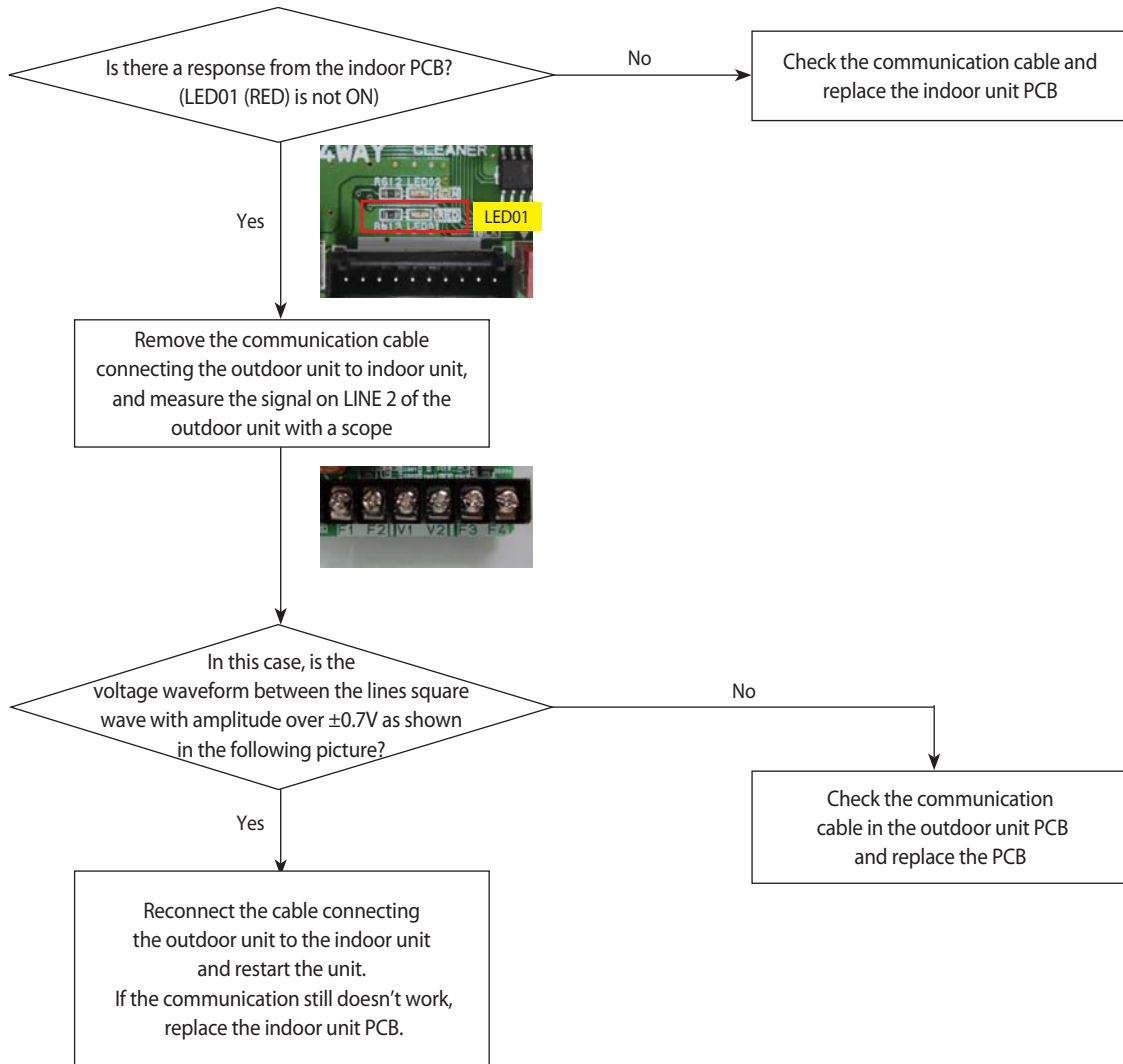

### 4-3-5 Indoor unit float sensor error

<b>Indoor unit display</b>	X (Operation) X (Defrost) ● (Timer) ● (Filter)
<b>Symptom</b>	The indoor unit floating sensor is open and that state is maintained for more than one minute
<b>Failure</b>	Increase in the drain pan water level due to failure of the indoor unit drain pump, or float sensor failure

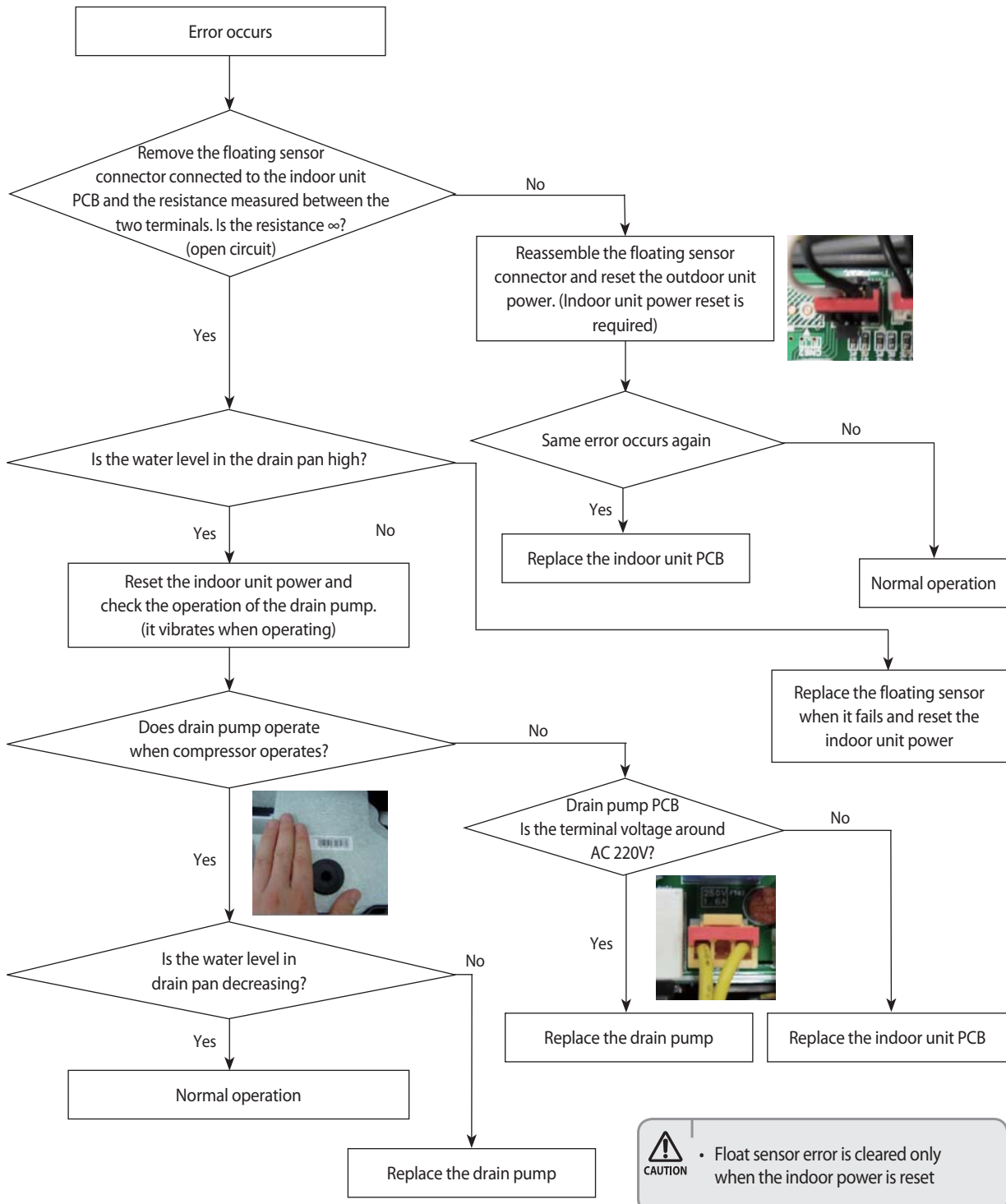

### 4-3-6 EEPROM circuit failure

Indoor unit display	● (Operation) ● (Defrost) ● (Timer) X (Filter)
Symptom	EEPROM circuit failure
Failure	EEPROM component failure, EEPROM circuit parts missing/damaged/soldering failure

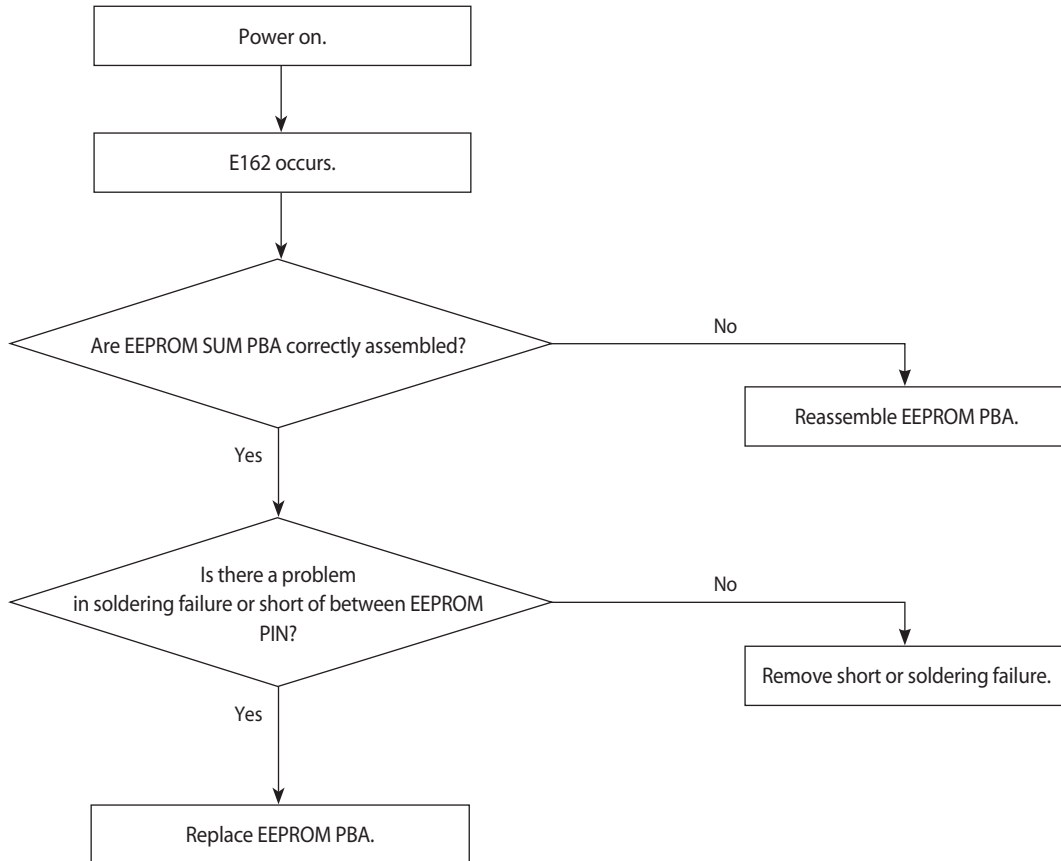

### 4-3-7 Thermal Fuse Open Error

<b>Indoor unit display</b>	X (Operation) ● (Defrost) ● (Timer) ● (Filter)
<b>Symptom</b>	Thermal Fuse Open Error
<b>Failure</b>	Check the connection of the CN140 wire. Check the connection of the terminal block. (Temperature rise by untightening a screw/ Termal Fuse open)

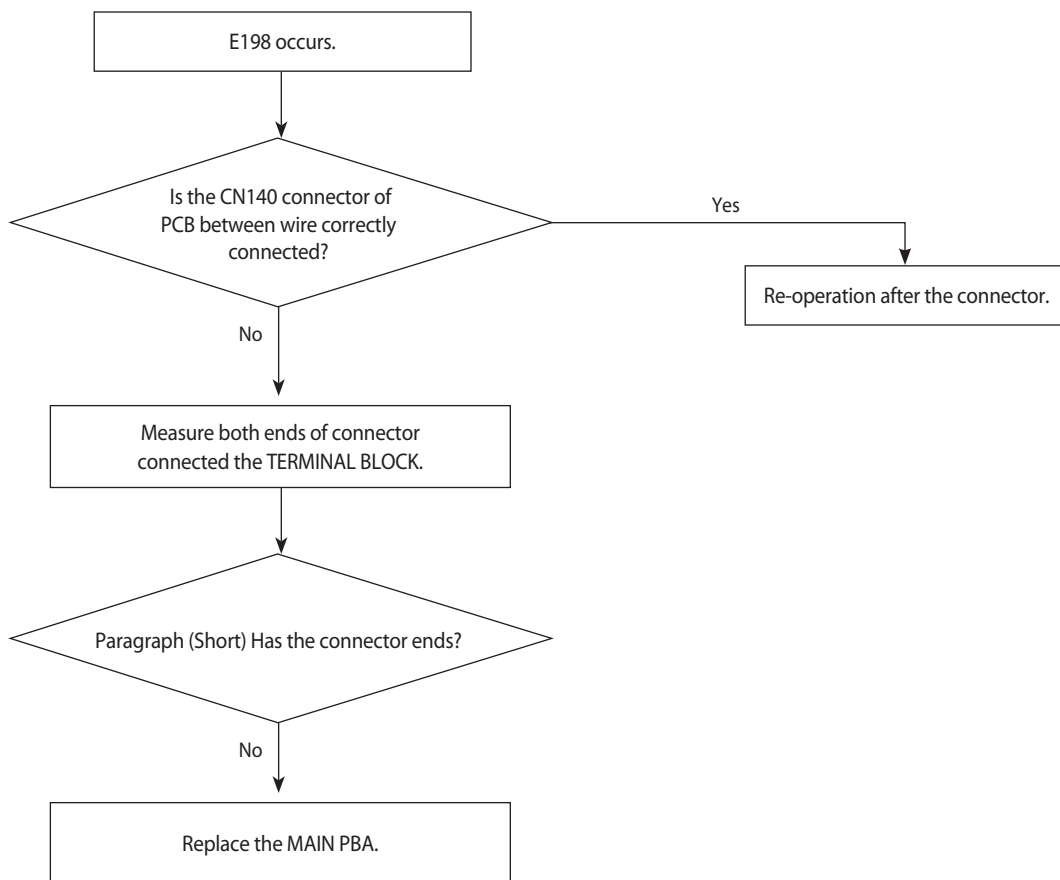



### 4-3-8 When the outdoor unit power is not ON – Initial Diagnosis : 3-phase products

1. Test Item

- 1) Check the power supply of the outdoor unit.
- 2) Check the whole connection part of the power supply.
- 3) Check the power on the indoor unit.
- 4) Check the connection of the power supply of the terminal block.
- 5) Check the connection of the power supply between the Main↔EMI PBA of the outdoor unit.
- 6) Connect the power supply. (Never forget to turn off the power of the terminal box).
- 7) Check the power supply parts. (Check after turning off the power of the terminal box!)
- 8) Check everything is normal after separating the fan motor connector and resetting the power.  
(Separate the connector after turning off the power of the terminal box!  
When detaching and attaching the connector during power supply, the motor can be damaged.)



- 7-segment off.
- Conduct the following test if the mode is not eco mode (power saving mode):

2. Check procedure

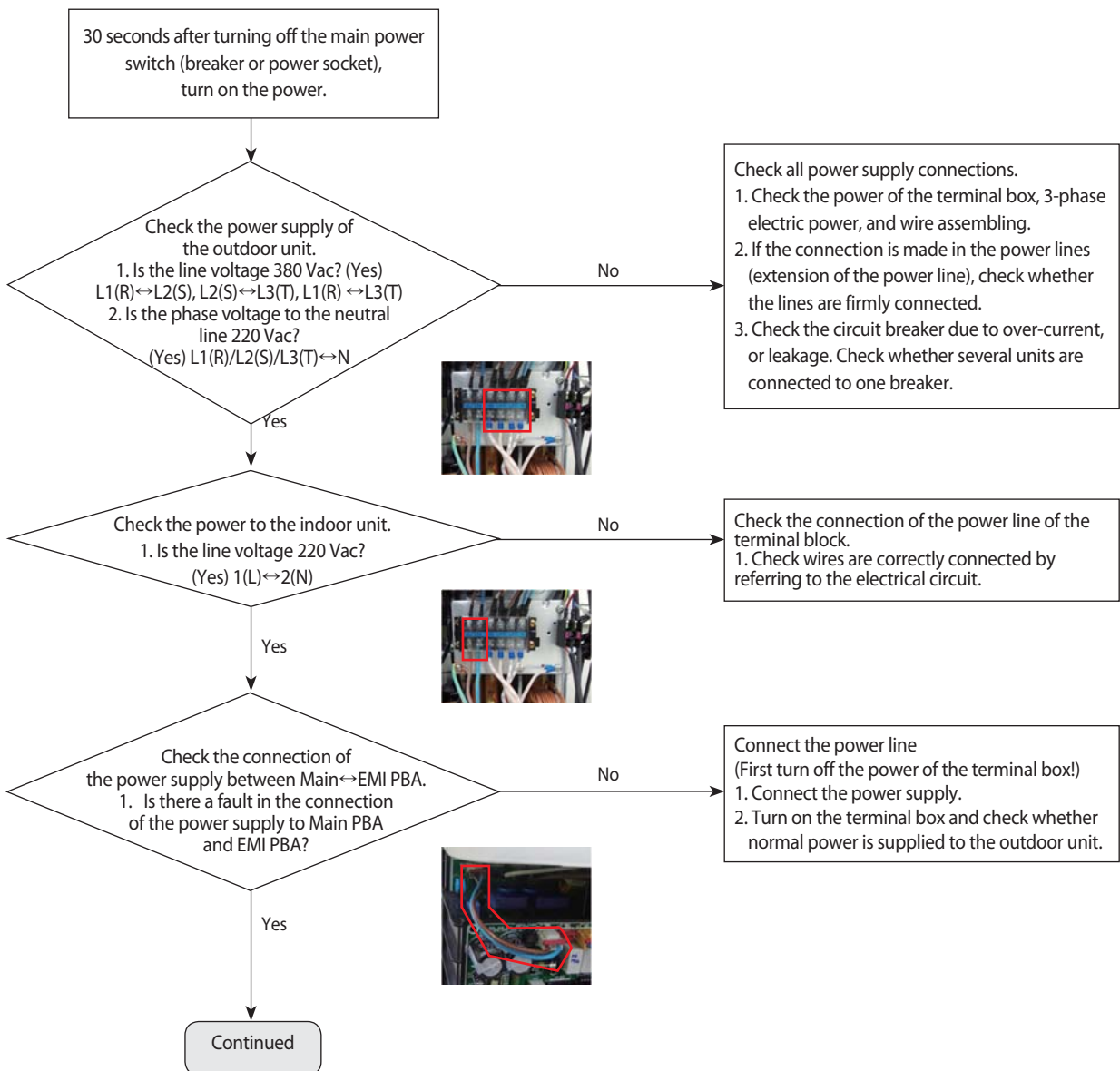

**When the outdoor unit power is not ON – Initial Diagnosis : 3-phase products** (Continued)

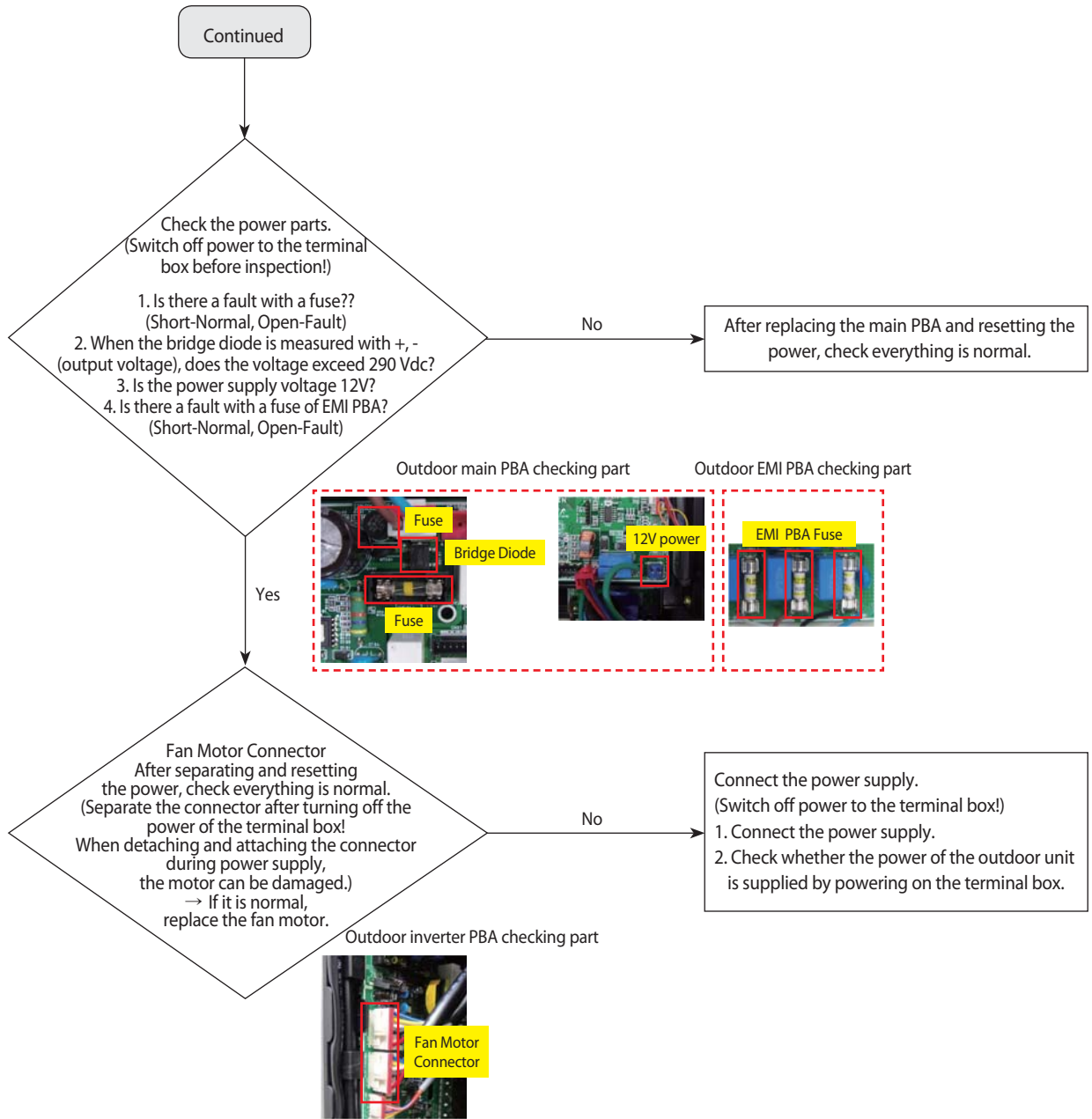

## When the outdoor unit power is not ON – Initial Diagnosis : Single-phase product

### 1. Test Item

- 1) Check the power supply to the outdoor unit.
- 2) Check the whole connection part of the power supply.
- 3) Check the power to the indoor unit.
- 4) Check the connection of the power supply to the terminal block
- 5) Check the connection of the power supply between the Main↔EMI PBA of the outdoor unit (RC072DHXB\* excluded).
- 6) Connect the power supply. (Never forget to turn off the power of the terminal box).
- 7) Check the power supply parts. (Check after turning off the power to the terminal box!)
- 8) Check everything is normal after separating the fan motor connector and resetting the power. (Separate the connector after turning off the power to the terminal box! When detaching and attaching the connector during power supply, the motor can be damaged.)

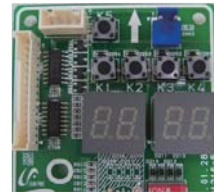

- 7-segment off.
- Conduct the following test if the mode is not eco mode (power saving mode):

### 2. Check procedure

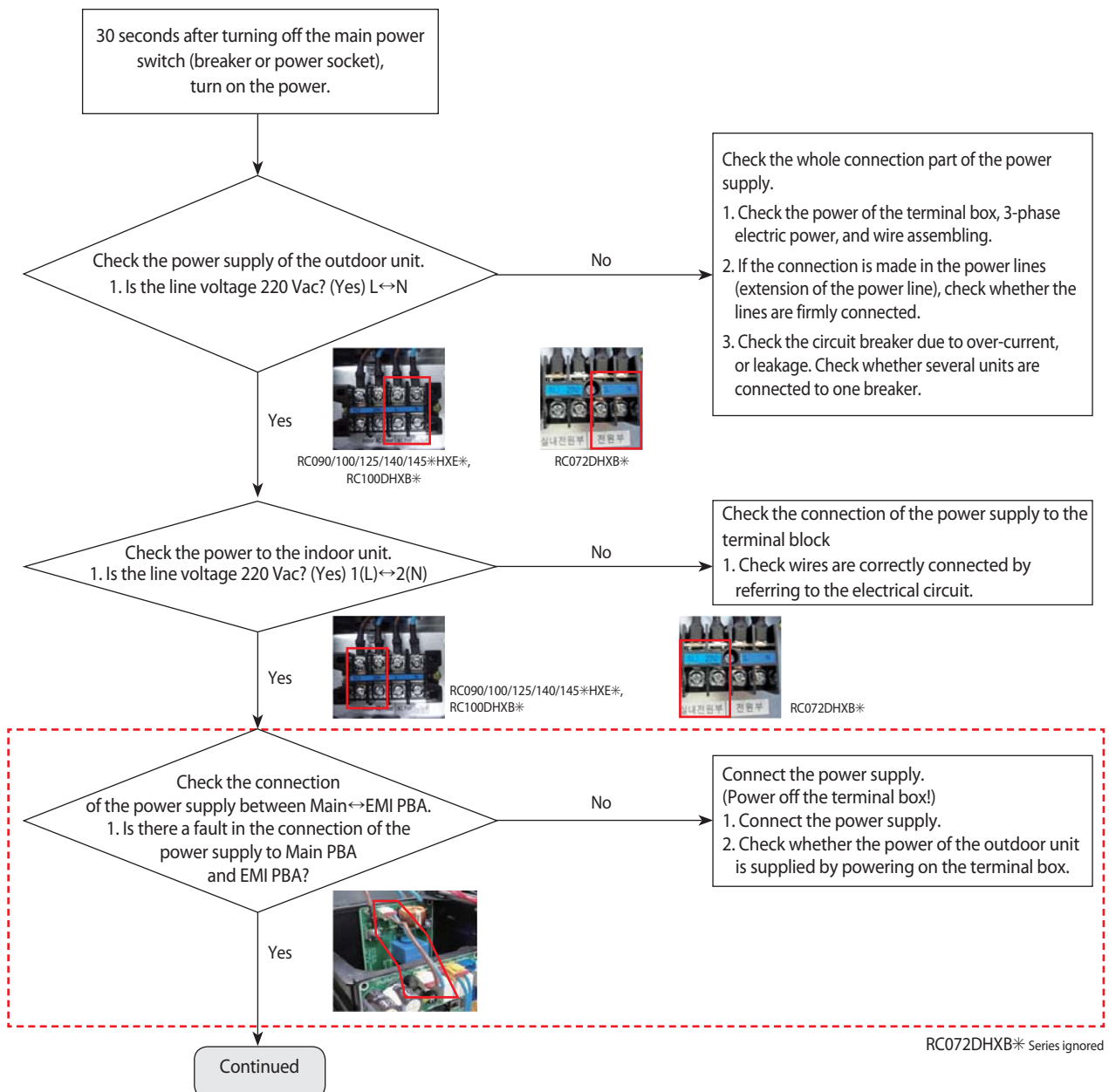

**When the outdoor unit power is not ON – Initial Diagnosis : Single-phase product (Continued)**

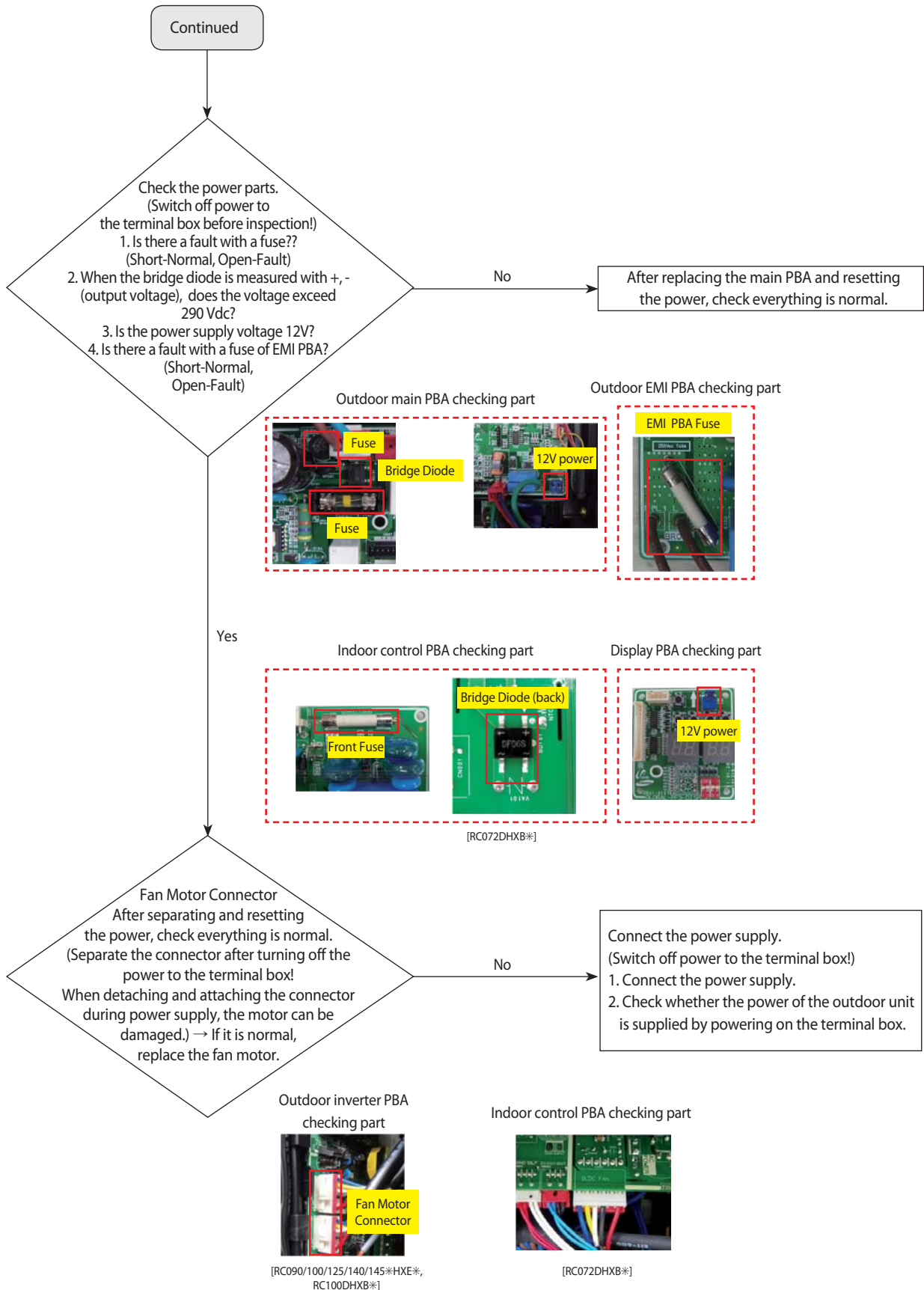

### 4-3-9 Indoor/outdoor communication error (1 min.) (Error Code: E202)

1. Test Item

- 1) Check the communication and power connection.
- 2) Check the communication connector connection.
  - RC072DHXB\* : Outdoor Unit Inverter PBA CN301
  - RC090/100/125/140/145\*HX\*\*, AC\*\*\*FCA\*\*\* : Outdoor Unit Main PBA CN31
- 3) Check the communication circuit on the PBA.

2. Check procedure

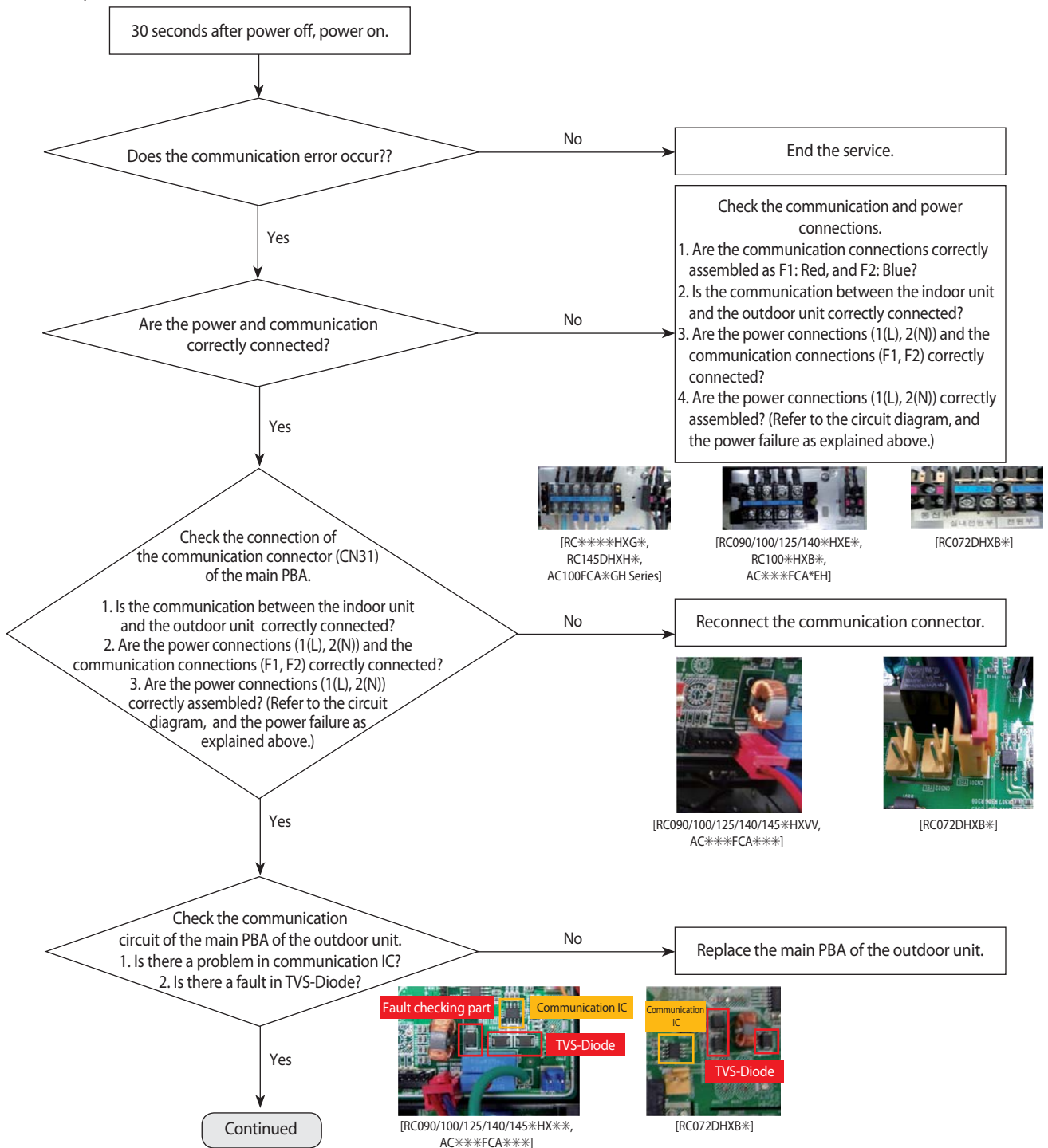

**Indoor/outdoor communication error (1 min.)**  
**(Error Code: E202) (Continued)**

Continued

Yes

Check the communication circuit of the main PBA of the outdoor unit.  
 1. Is there a problem in communication IC?  
 2. Is there a fault in TVS-Diode?

Measuring Part	Communication IC Measuring Part (Circuit Diagram)	Example of Measuring Communication IC	Example of Measuring TVS-Diode
Location			
Measuring Point	#5-GND, #6- Communication A, #7- Communication B, #8-Vcc		

Communication IC Measuring (Port)	Steady-state Measuring Value		Remark
	COM 1 (RED)		
#6 - #5	0.9kΩ ~ 1.2kΩ		Measuring after separating the communication connection
#7 - #5	0.9kΩ ~ 1.2kΩ		
#8 - #5	4.7Vdc ~ 5.3Vdc		

TVS-Diode Measuring	Steady-state Measuring Value
Both ends of diode	1kΩ or above



### 4-3-10 Communication error between outdoor unit INV ↔ MAIN MICOM (1 min.) (Error Code: E203)

1. Test Item

- 1) Is the power of the outdoor unit inverter PBA on?
- 2) Check the power connection and fuse.
- 3) Is there a problem in the communication connections between the outdoor unit inverter (CN31) and main PBA (CN39)?  
(RC072DHXB\* excluded)
- 4) Check the communication connections.

2. Check procedure

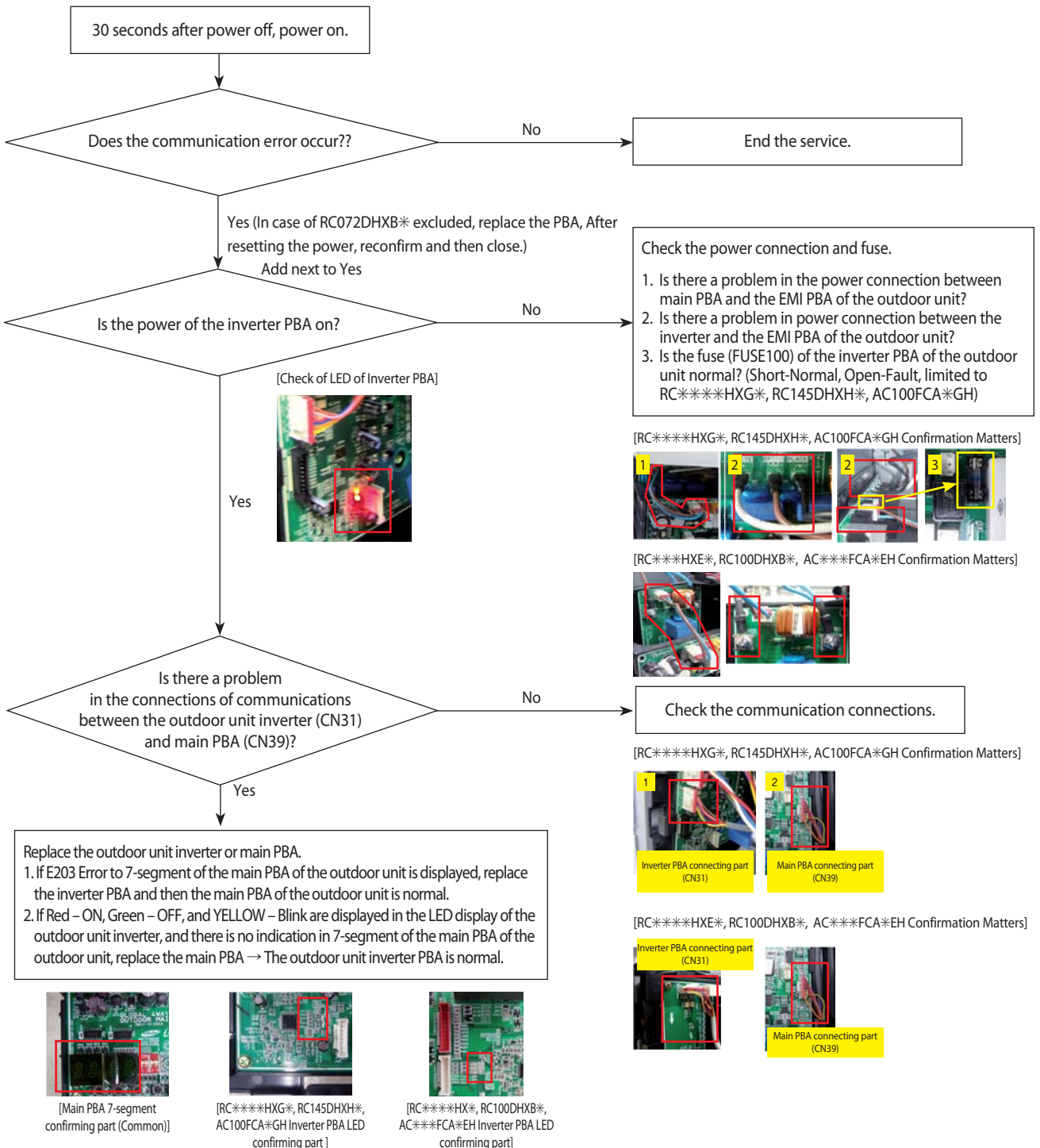



### 4-3-11 External Sensor Error (Error Code: E221, E231, E251, E320)

1. Test Item

- 1) Check the connection of the temperature sensor connector.
- 2) Check the resistance value of the temperature sensor.

Error Code	Description
E221	Error of the temperature sensor of the outdoor unit
E231	Error of the COND. sensor of the outdoor unit
E251	Error of the discharge sensor of the outdoor unit
E320	Error of the OLP sensor of the outdoor unit

2. Check procedure

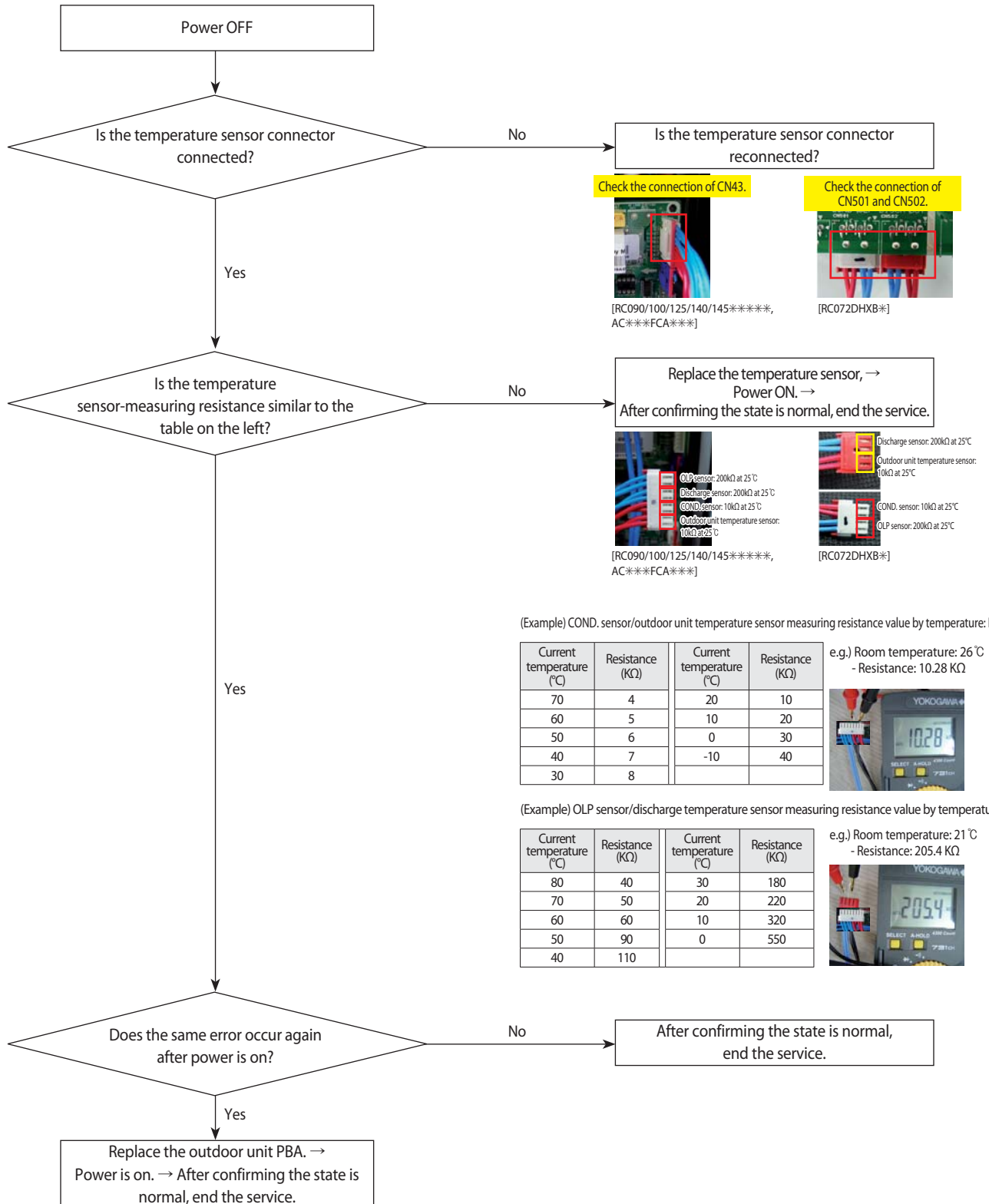

### 4-3-12 Outdoor Unit Fan Error (Error Code: E458, E475)

1. Test Item

- 1) Check the connection of fan connectors (CN90, CN91). [In case of RC072DHXB\*, CN901]
- 2) Check the voltage of the fan motor connector in the inverter PBA of the outdoor unit.
- 3) Check the power supply of the inverter PBA of the outdoor unit.
- 4) Check the single fan motor. (Do not forget to separate the motor connector 30 seconds after power off!)

2. Check procedure

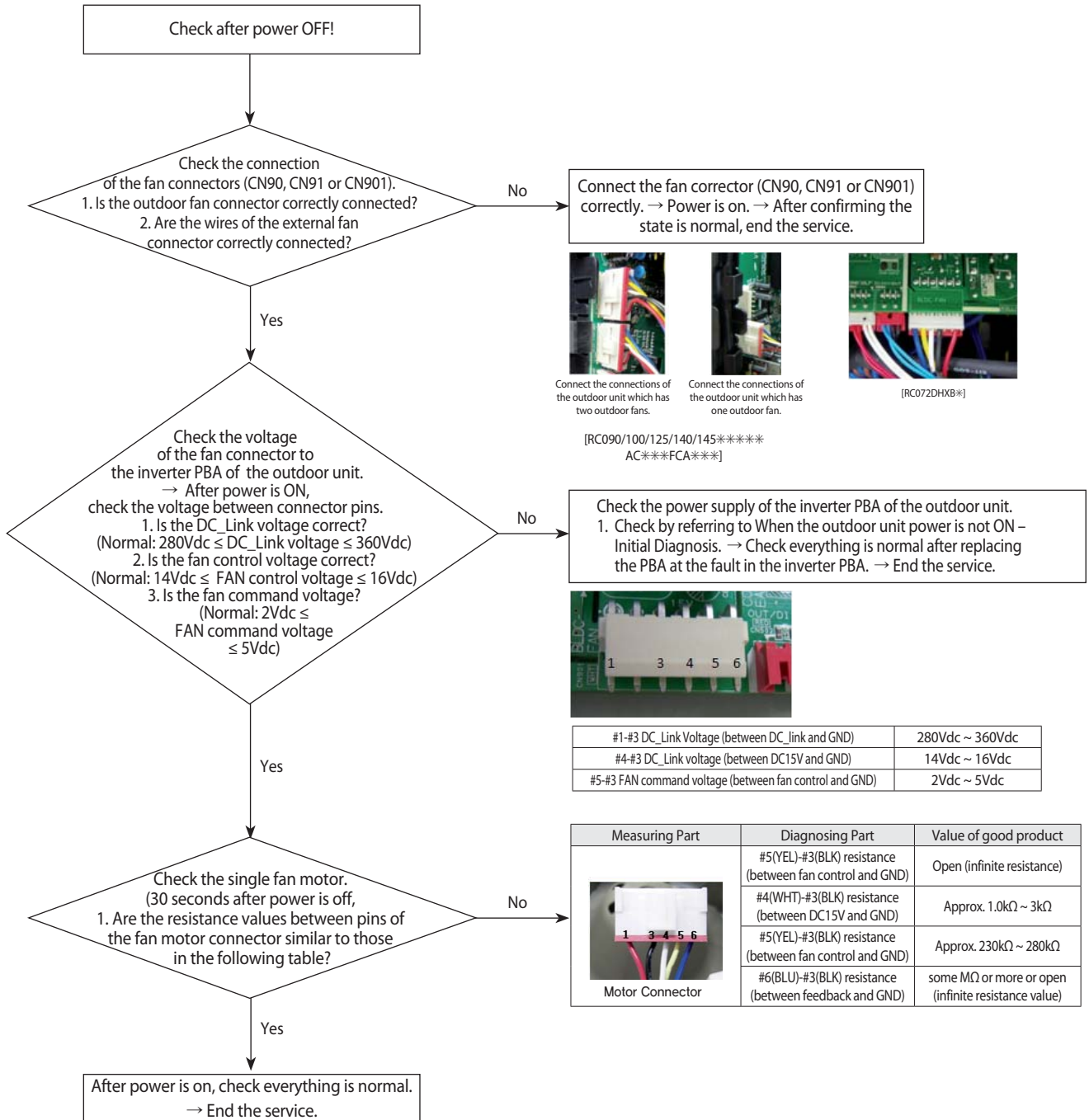

※ At least 30 seconds after power is OFF, attach/detach the fan motor connector! → Threatened to cause secondary damage to the motor and the PBA.  
 ※ Check the single inverter PBA or fan motor and only if there is a fault, replace!  
 ※ Do not replace the main PBA of the outdoor unit relating to the fault in the fan motor!  
 ※ If the error is indicated on 7-segment of the main PBA of the outdoor unit, the main PBA of the outdoor unit has no fault.  
 ※ In case of a control problem, it is possible to solve with S/W update.

### 4-3-13 Error of Compressor Startup and Rotation (Error Code: E461, E467)

1. Test Item
  - 1) Check the power supply / Check the restart-up after power is reset.
  - 2) Check the compressor and the state of the compressor wire assembling.
  - 3) Check the fault of the single compressor wire.
2. Check procedure

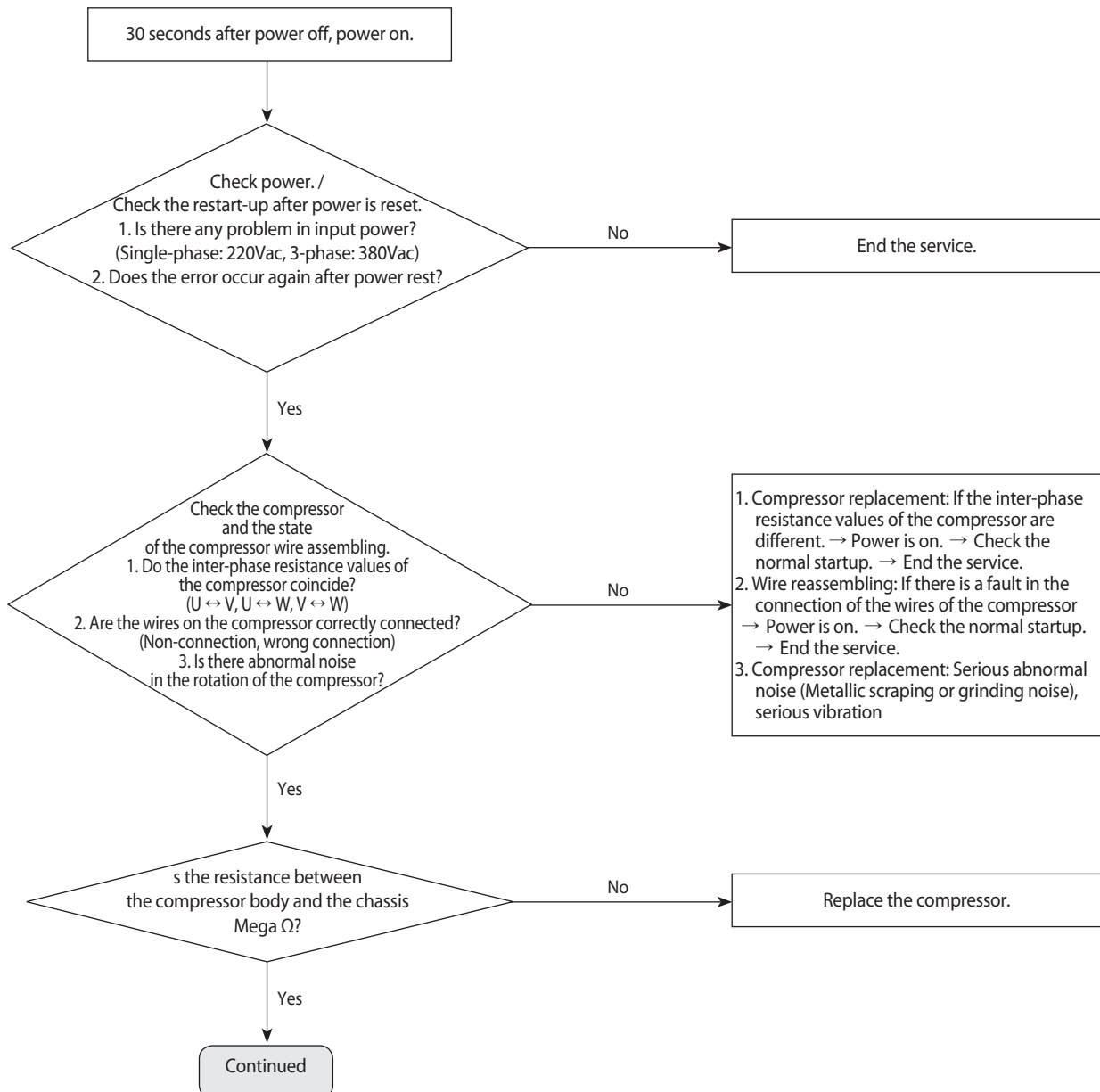

## Error of Compressor Startup and Rotation (Error Code: E461, E467) (Continued)

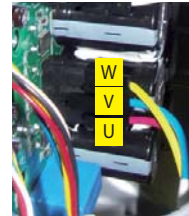
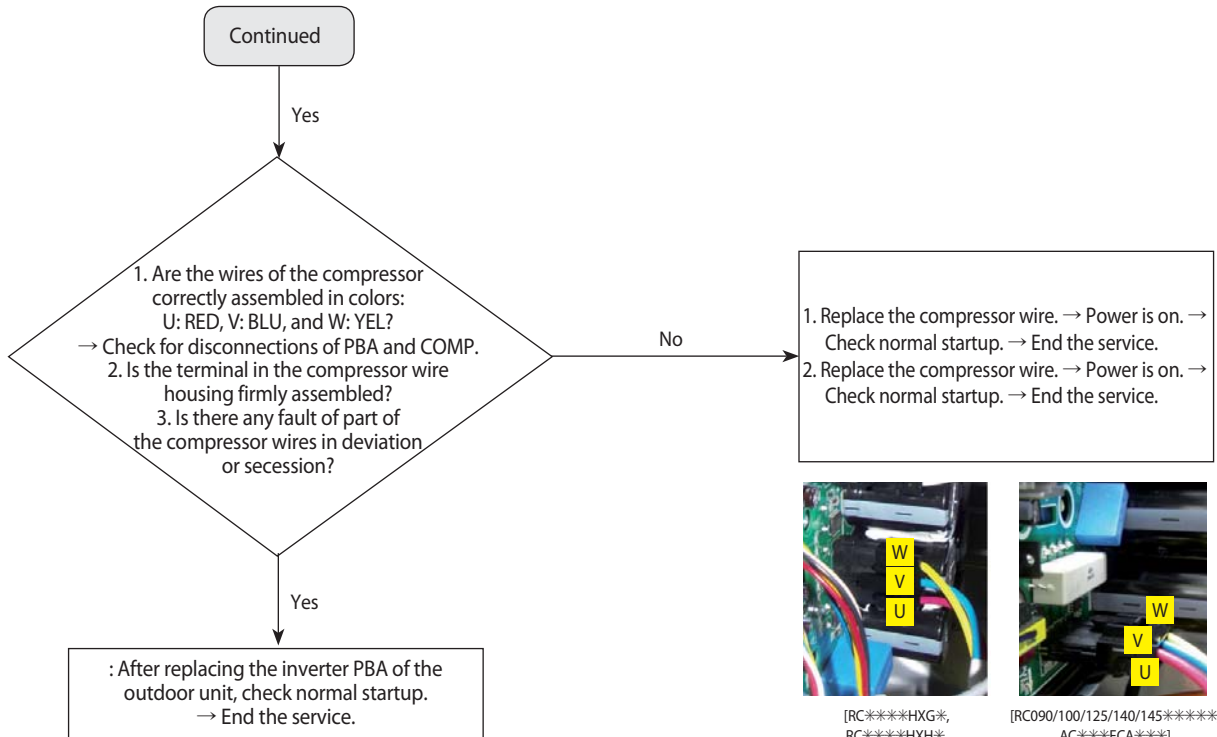

[RC\*\*\*\*HXG\*,  
RC\*\*\*\*HXH\*,  
AC100FCA\*GH]



[RC090/100/125/140/145\*\*\*\*\*,  
AC\*\*\*FCA\*\*\*]

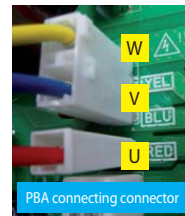

PBA connecting connector

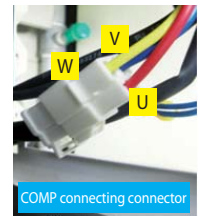

COMP connecting connector

[RC072DHXB\*]

- ※ E461, E467 Error-related, EMI / outdoor unit Main / Indoor unit Main PBA do not replace!  
→ This error is related to the compressor and Inverter PBA. (Not related to the above PBA)
- ※ Because it is an error regarding the inverter PBA, it is not related to the aforementioned PBA.
- ※ Ensure that the service valve is open!
- ※ While the service valve is closed and the COMP. starts, it is possible to cause a fault due to differential pressure.

### 4-3-14 Error of under-current error / PFC over-current (Error Code: E462, E484)

1. Test Item

- 1) Check the power supply. / Check the re-startup after the power is reset.
- 2) Check the outdoor unit installation environment.  
→ Check the disconnection of the wires regarding the inverter PBA of the outdoor unit and check the installation environment.
- 3) Check the indoor unit installation environment.
- 4) Check the opening of the service valve.

Error Code	Description	Model
E462	Error of the outdoor unit under-current	RC****HX**, AC****FCA**
E484	Error of the outdoor unit PFC over-current	Limited to RC****HXE*, RC****HXB*, AC****FCA*EH

2. Check procedure

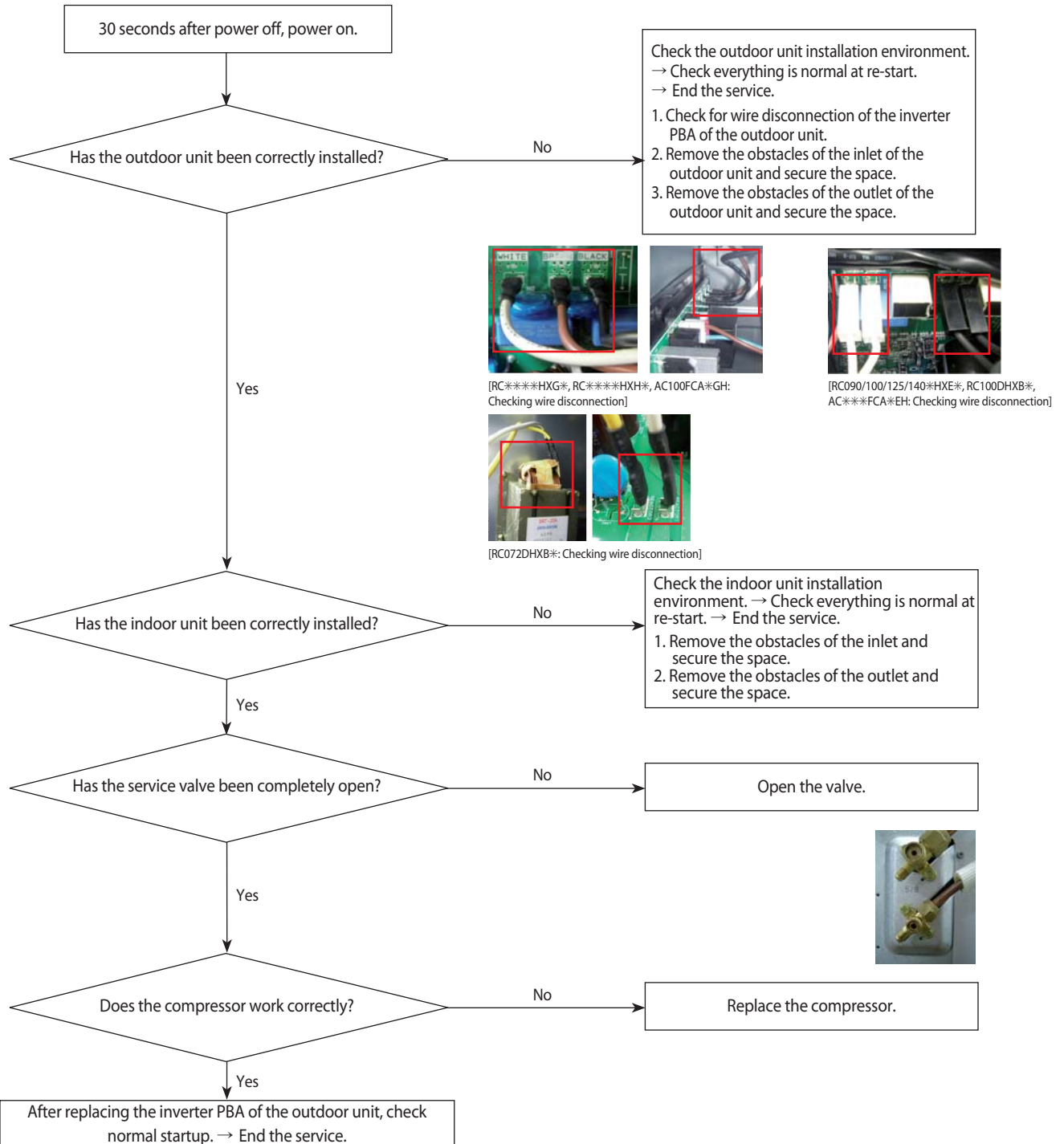

### 4-3-15 IPM Over-current Error (Error Code: E464)

1. Test Item

- 1) Check the power supply. / Check the re-startup after the power is reset.
- 2) Check the outdoor unit installation environment.
  - Check the disconnection of the wires regarding the inverter PBA of the outdoor unit and check the installation environment.
  - At the site where several units were installed at the same time, check whether communication connections and pipes have been wrongly connected!
- 3) Check the indoor unit installation environment.
- 4) Check the opening of the service valve.
- 5) Check the compressor and the state of the compressor wire assembling.
- 6) Check for fault of the single compressor wire.

2. Check procedure

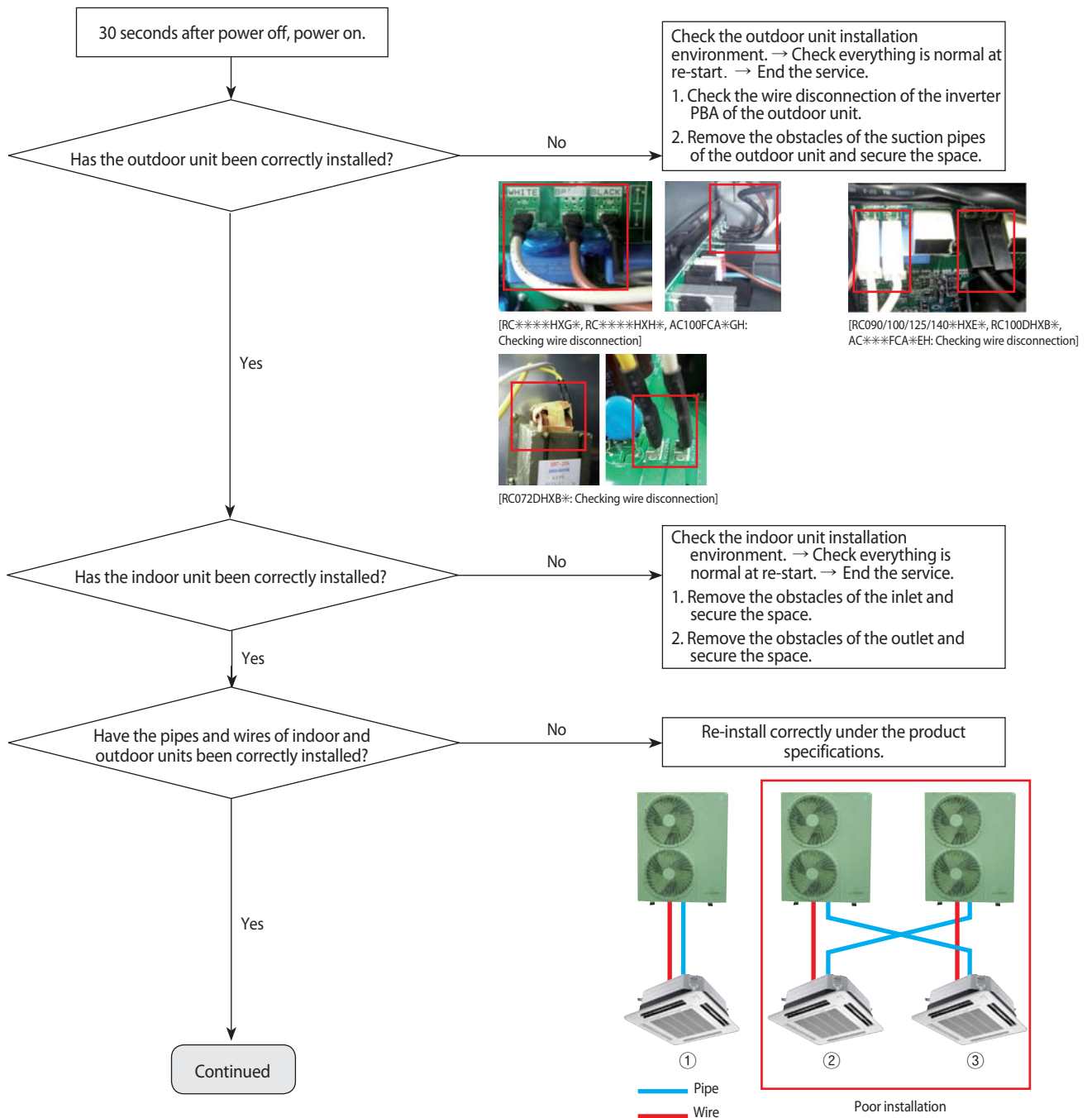

## IPM Over-current Error

(Error Code: E464)(Continued)

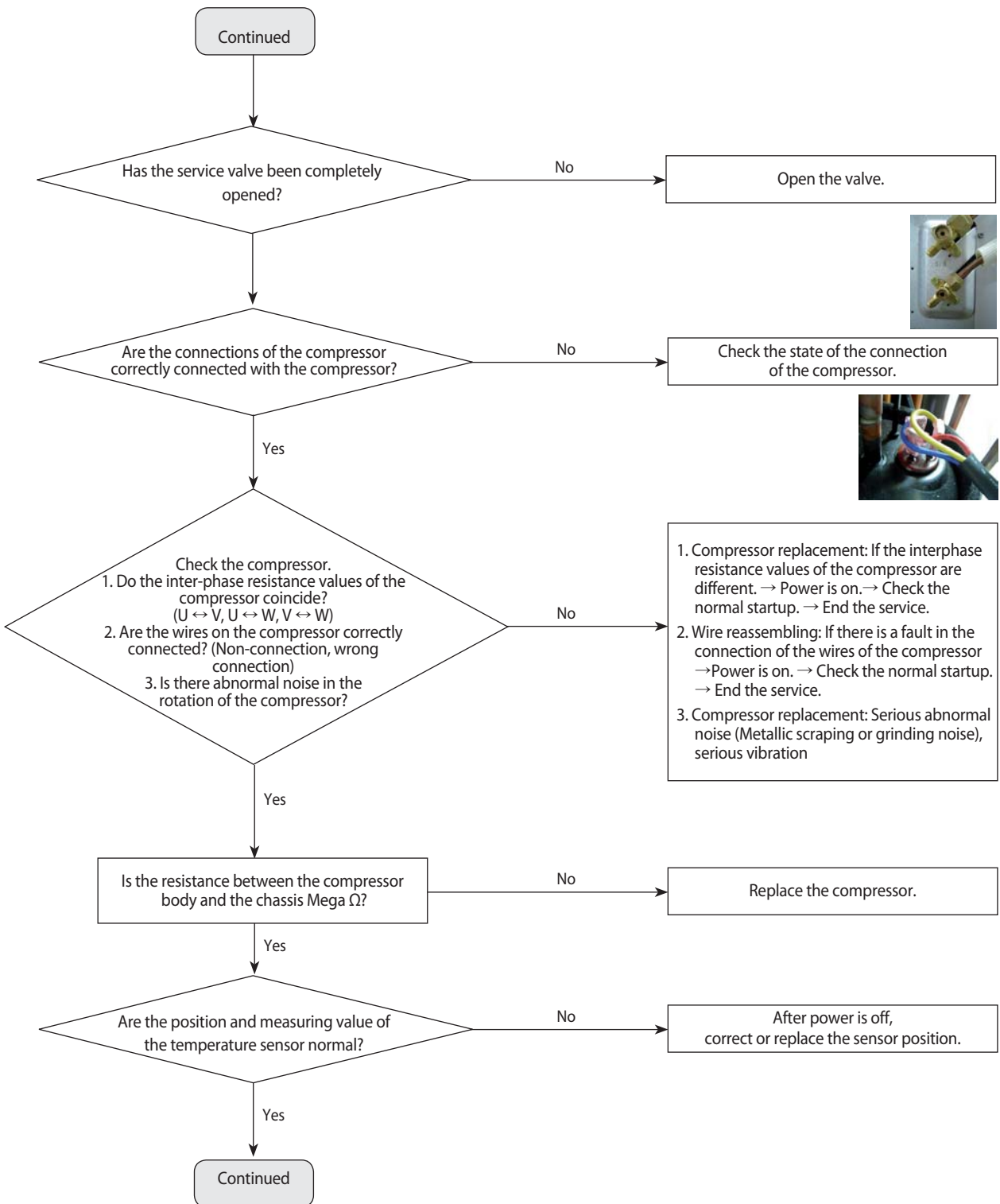



## IPM Over-current Error

(Error Code: E464)(Continued)

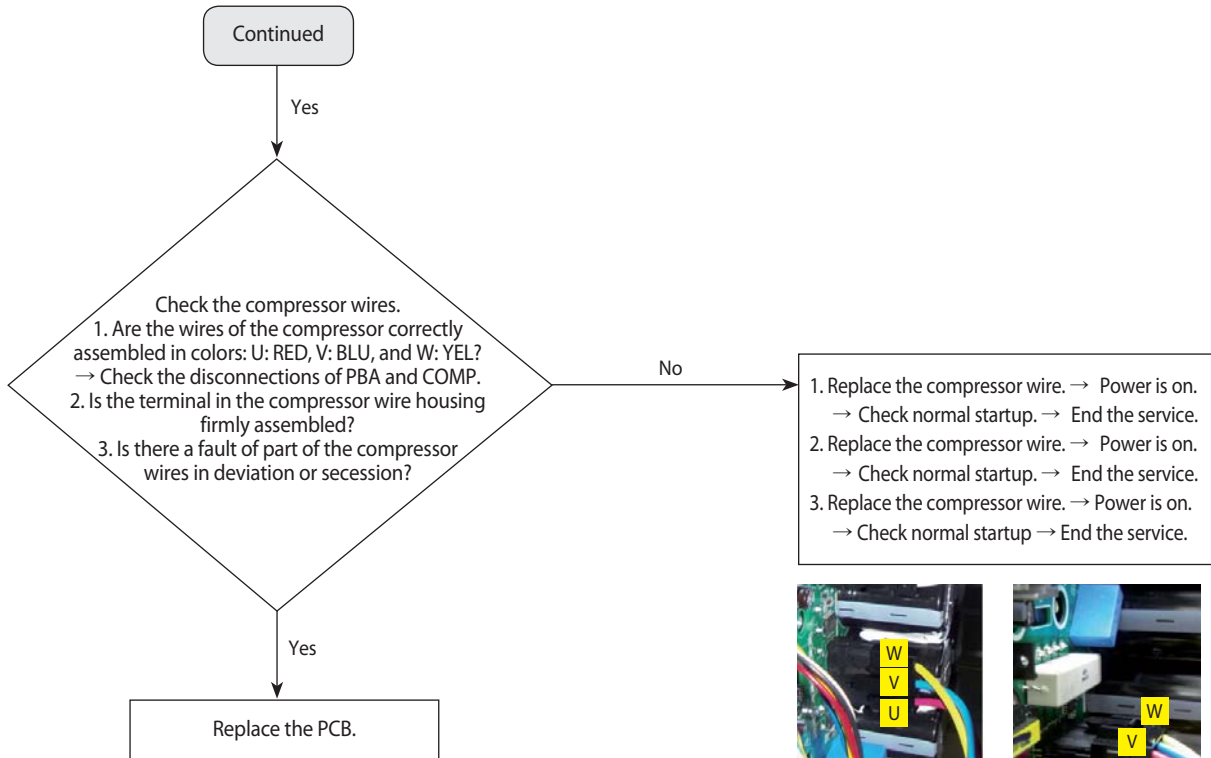

[RC\*\*\*\*HXG\*,  
RC\*\*\*\*HXH\*,  
AC100FCA\*GH]



[RC090/100/125/140/145\*HX\*\*,  
AC\*\*\*FCA\*\*\*]

※ E464 Error-related, EMI / outdoor unit Main / Indoor unit Main PBA do not replace! → This error is related to the compressor and Inverter PBA. (Not related to the above PBA)

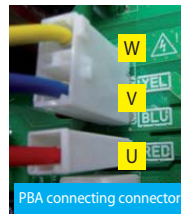

PBA connecting connector

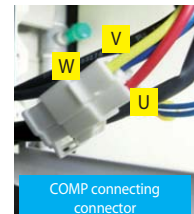

COMP connecting connector

[RC072DHXB\* Series]

### 4-3-16 DC LINK Over-current and Low-voltage Error (Error Code: E466)

1. Test Item

- 1) Check the power supply. / Check the re-startup after the power is reset. → Is there a fault in input power?  
→ Does the error occur again at operation after power is reset?
- 2) Check the connection of the power, and check whether the jointed power connection exists.
- 3) Check the reactor and its connecting wires.
- 4) Check the fuses of EMI PBA.
- 5) Check the terminal block and power terminal box and the wire assembly.

2. Check procedure

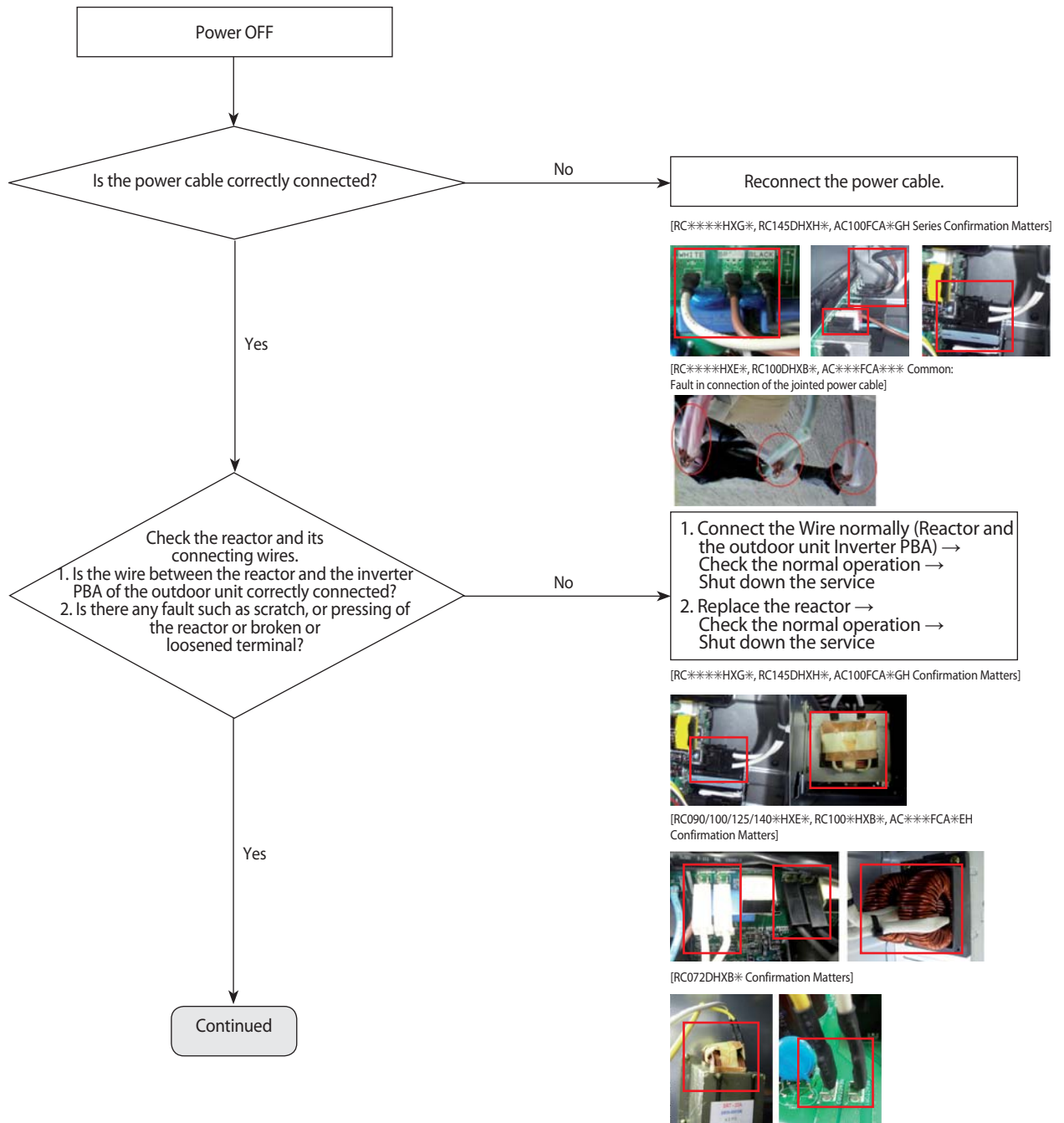

## DC LINK Over-current / Low Voltage Error (Error Code: E466)

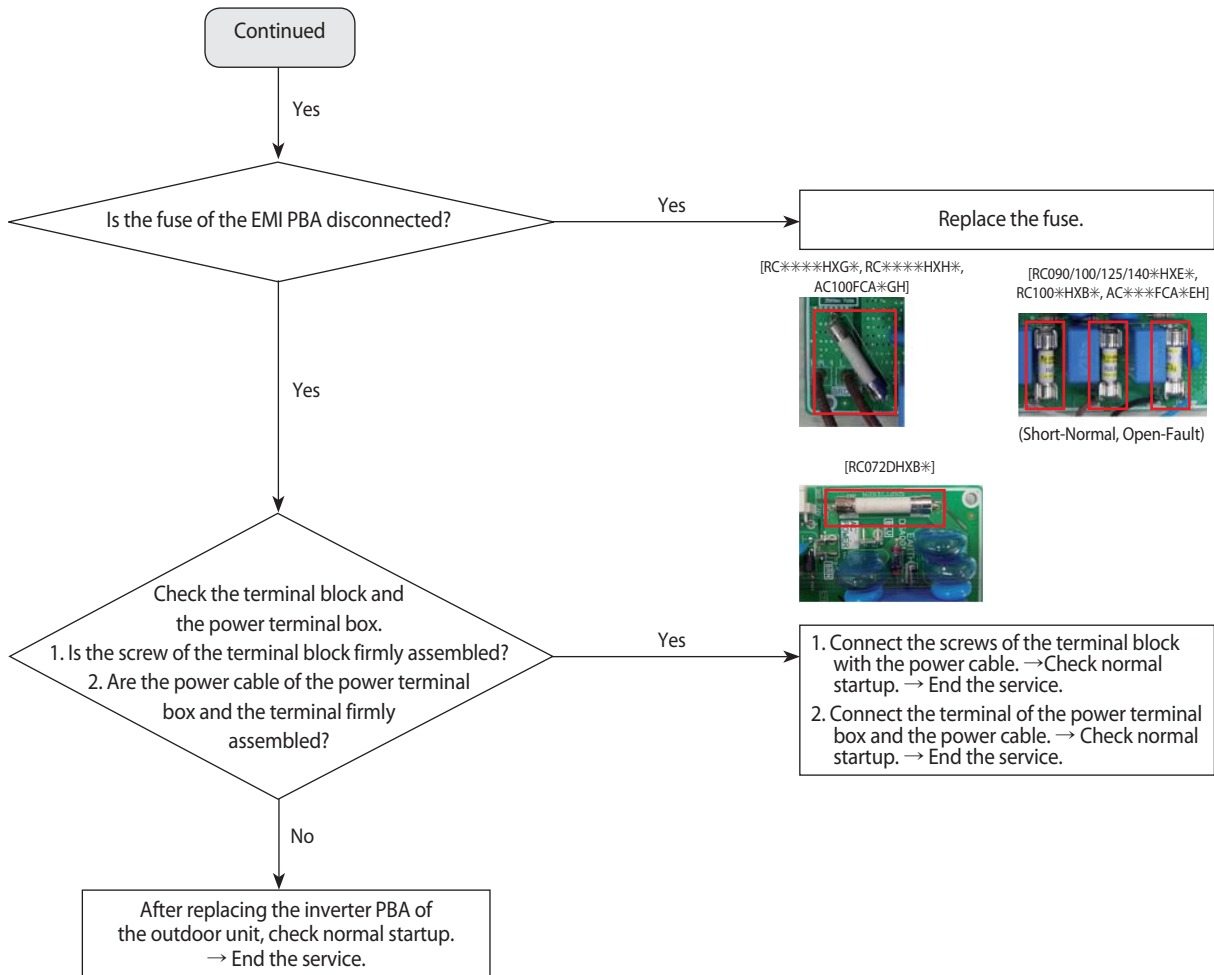

### 4-3-17 Gas Leakage Error (Error Code: E554)

1. Test Item

- 1) Check the power supply. / Check the re-startup after the power is reset. → Is there a fault in input power?  
→ Does the error occur again at operation after power is reset?
- 2) Check the compressor and the state of the compressor wire assembling.
- 3) Check the outdoor unit installation environment. → Check for disconnection of the wires regarding the inverter PBA of the outdoor unit and check the installation environment. → At the site where several units were installed at the same time, check whether communication connections and pipes have been wrongly connected!

2. Check procedure

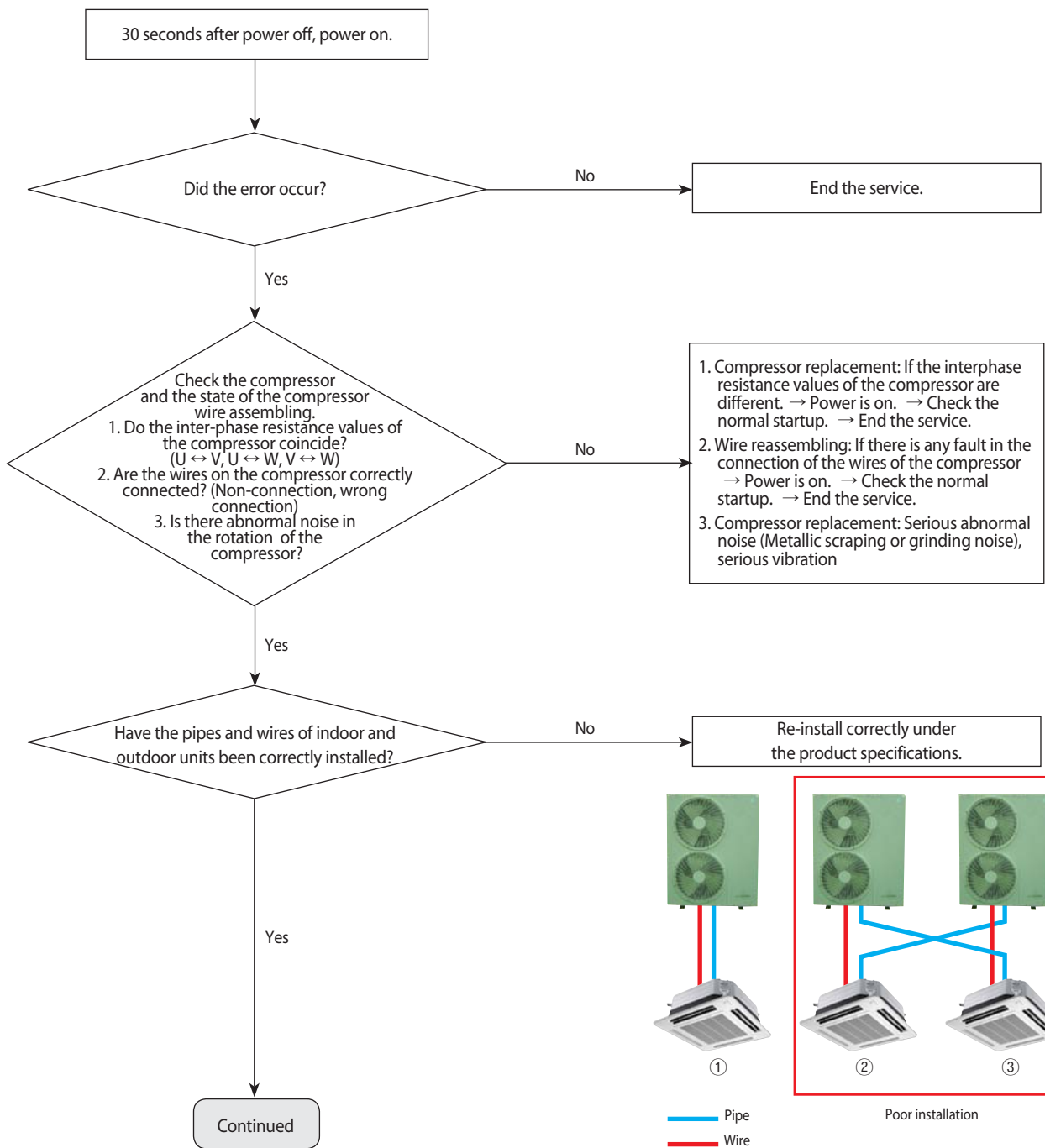

### Gas Leakage Error (Error Code: E554) (Continued)

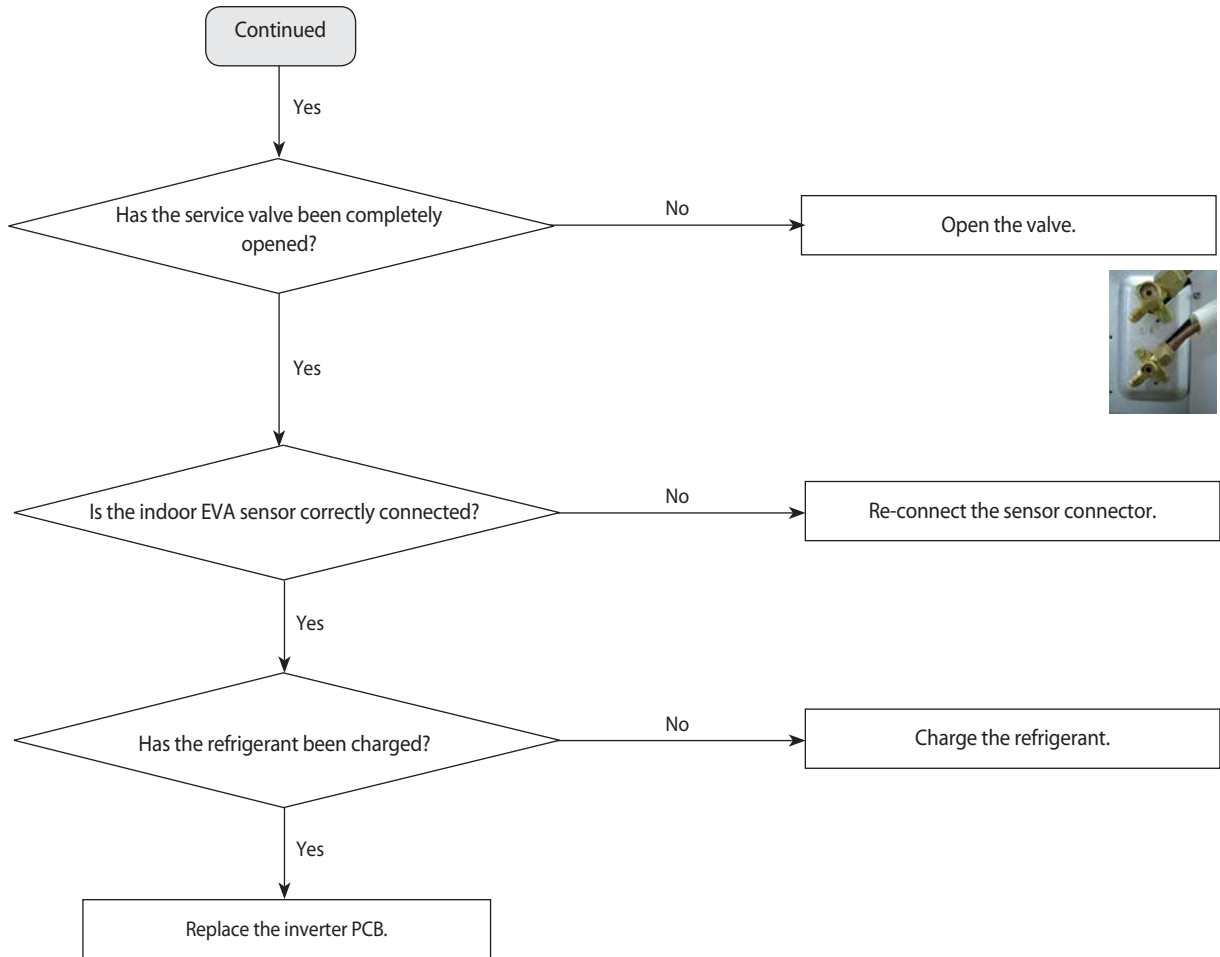

### 4-3-18 Pipe Blocking Error (Error Code: E422)

1. Test Item

- 1) Check the open state of the outdoor unit service valve.
- 2) Check the connection of the pipe.
- 3) Check the operation of the EEV.
- 4) Check the refrigerant leakage.
- 5) Check the connection of the indoor unit PBA EVA sensor.
- 6) Check the fault in the indoor unit EVA sensor.

2. Check procedure

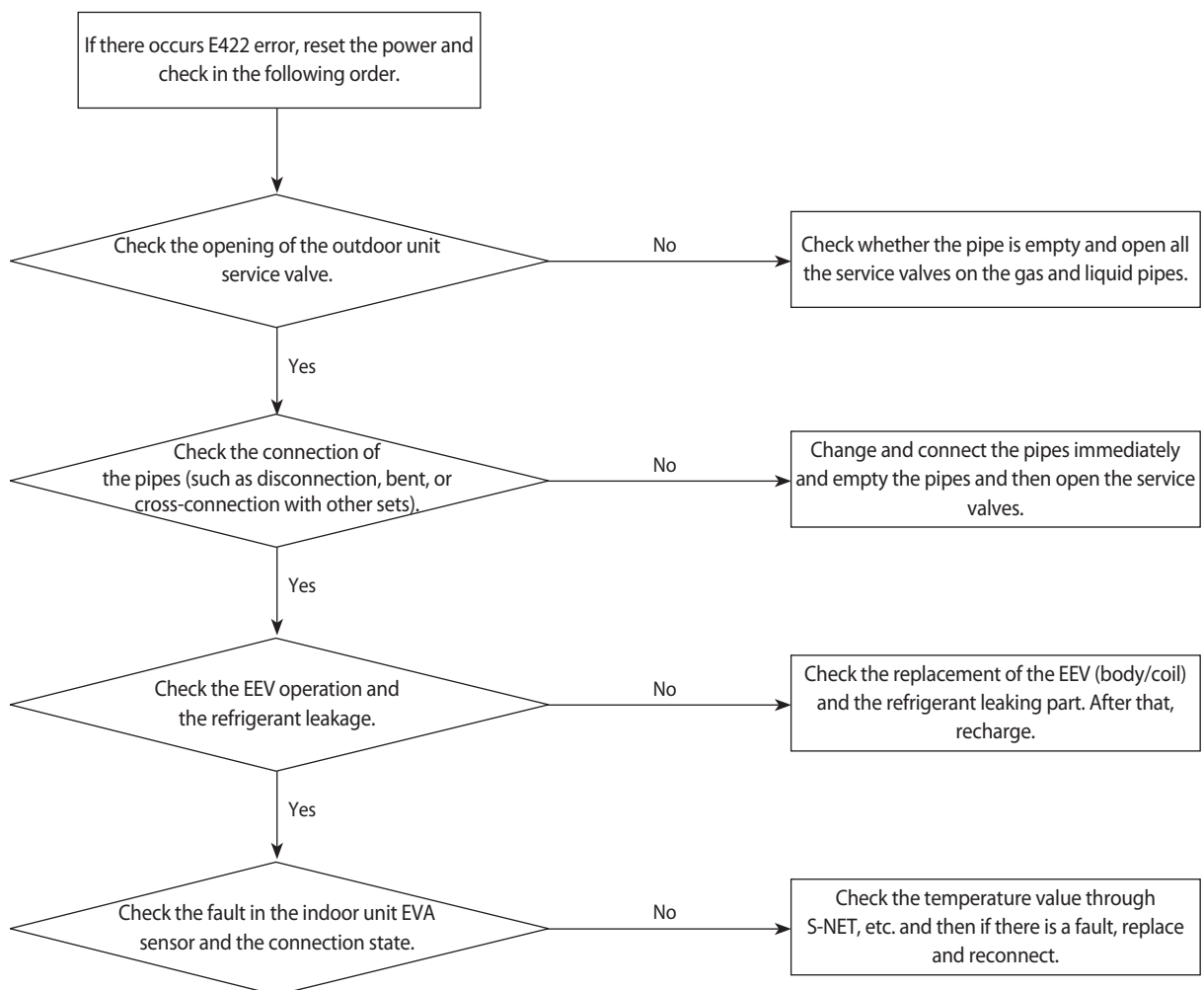

### 4-3-19 Other

1. Current sensor error: Upload EEPROM to the main PBA of the outdoor unit.  
After checking for normal operation of PCB, replace the inverter PCB.
2. Compressor Vlimit error: E465  
If the compressor is abnormally run, replace the compressor and then ensure that it works normally.  
→ If the compressor is normally run, check the assembling between the heatproof plate and the inverter PBA and then if there is no abnormality, replace the inverter PBA.
3. OTP error: E471  
Upload EEPROM to the main PBA of the outdoor unit.
4. Capacity inconsistency error: E556  
Check the model name between the outdoor and indoor unit and re-enter the option code to the indoor unit.
5. 3-phase power cable disconnection: E424  
Check for disconnection of the 3-phase (open) power cable, and check the disconnected EMI PBA fuse.

[RC\*\*\*\*HXH Series Confirmation Matters]



6. Outdoor unit freezing detection (at the stop of the compressor): E403  
Outdoor overload protection control (at the stop of the compressor): E404
  - Check whether the fan and the motor operate normally.
  - Check the operation of EEV.
  - Check the temperature sensor of the indoor unit heat exchanger.
  - Check the indoor unit inlet blocking.
7. Outdoor unit compressor discharging temperature protection control: E416
  - Check for lack of refrigerant.
  - Check the blocking of the solenoid valve.
  - Check the malfunction of the exhaust temperature sensor.
  - Check EEV.
8. Error of impossibility to operate heating at outdoor temperature exceeding 30°C: E440  
Error of impossibility to operate cooling at outdoor temperature of -5°C or under: E441
  - It is not the error code in the product and it is a specification to protect the product by limiting the temperature scope of use.
  - Use by referring to the temperature scope of use on the product manual, etc.
9. OLP overheating and compressor stop: E463
  - Check the opening of the sub-valve.
  - Check the amount of the cooling water.
  - Check OLP sensor.
10. Current sensor error: E468
  - Check EEPROM data.
  - Check PCB operation.
11. IPM (IGBT Module) or PFCM temperature sensor error: E474  
IPM overheat error for outdoor unit inverter compressor: E500
  - Check whether IPM is correctly assembled on the heatproof plate.
  - Check whether the inlet is blocked.
  - If there is a defect, replace IPM.

# 5. PCB Diagram and Parts List

## 5-1 Indoor Unit

### 5-1-1 MAIN PCB

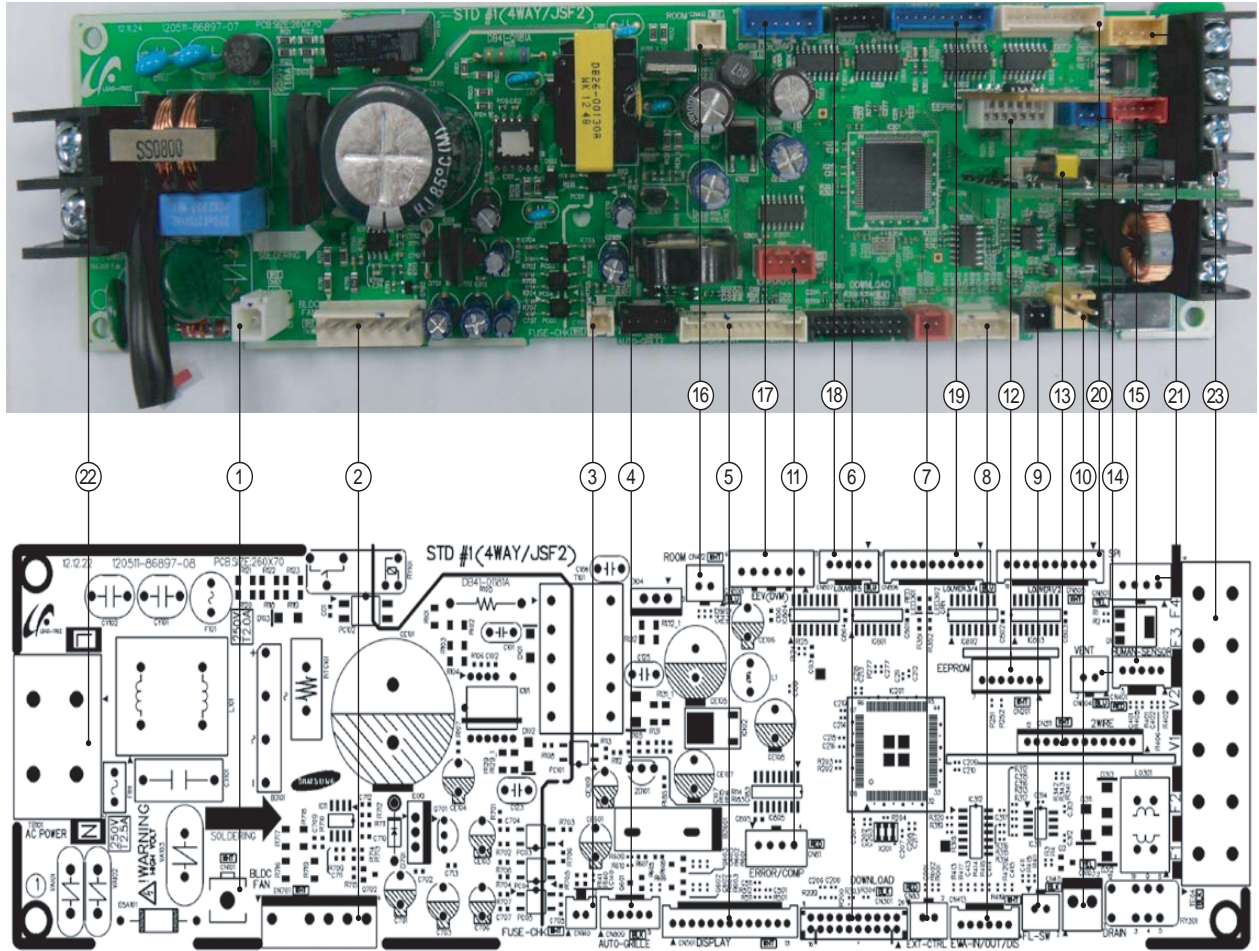



<b>① CN101-GND</b> #1 : GND	<b>② CN701-BLDC MOTOR</b> #1: DC310V #3 : GND #4 : DC15V #5 : FAN RPM #6 : RPM FEEDBACK	<b>③ CN140-FUSE CHECK</b> #1: FUSE CHECK SIGNAL #2: GND	<b>④ CN809-AUTOMATIC ELEVATING GRILLE</b> #1 : DC12V #4 : REMOCON SIGNAL #5 : GND	<b>⑤ CN501-DISPLAY</b> #1: DC 12V #2: LED_0 #3: LED_1 #4: LED_2 #5: LED_3 #6: LED_4 #7: LED_5 #8: REMOCON OUTPUT SIGNAL #9: AUTO SWITCH #10: REMOCON INPUT SIGNAL #11: GND #12: DC5V #13: GND
<b>⑥ CN301-DOWNLOAD</b>	<b>⑦ CN83-EXT CTRL</b> #1: GND #2: EXT-CTRL SIGNAL	<b>⑧ CN413: THERMISTOR</b> #1:EVA-IN THERMISTOR #2:GND #3 : EVA-OUT THERMISTOR #4: GND #5 : DISCHARGE THERMISTOR #6: GND	<b>⑨ CN411- FLOAT SWITCH</b> #1: F/S SIGNAL #2: GND	<b>⑩ CN103-DRAIN PUMP</b> #1: D/P POWER(DC12V) #2: GND
<b>⑪ CN81-ERROR/COMP CHECK</b> #1: DC12V #2: ERROR SIGNAL OUTPUT(GND) #3: DC12V #4: COMP/OPER. SIGNAL OUTPUT(GND)	<b>⑫ CN201-EEPROM</b> #1: GND #3: DC5V #4: EEPROM_SELECT #5: EEPROM_SO #6: EEPROM_SI #7: EEPROM_CLK	<b>⑬ CN311-2WIRED REMOCON</b> #1:DC12V #2:COM2_PCTRL_MICOM #3:COM2_VCHECK_A #4:COM2_VCHECK_B #5:COM2_MICOM_AD #6:DC5V #8:COM2_C #9:COM2_D #10:COM2_TXD #11:COM2_RXD #12:GND	<b>⑭ CN804-VENTILATOR</b> #1: DC12V #2: VENTILATOR SIGNAL OUTPUT (GND)	<b>⑮ CN401-HUMAN SENSING SENSOR</b> #1: DC12V #2: HUMAN SENSING SENSOR COMM(TXD) #3: HUMAN SENSING SENSOR COMM(RXD) #4: GND
<b>⑯ CN412-INDOOR THERMISTOR</b> #1:INDOOR THERMISTOR #2:GND	<b>⑰ CN808-EEV</b> #1~#4: EEV SIGNAL OUTPUT #5: DC12V #6:DC12V	<b>⑱ CN807-LOUVERS</b> #1:DC12V #2~#5: LOUVER SIGNAL OUTPUT	<b>⑲ CN806-LOUVER3/4</b> #1 : DC12V #2~#5: LOUVER SIGNAL OUTPUT #6 : DC12V #7~#10: LOUVER SIGNAL OUTPUT	<b>⑳ CN805-LOUVER1/2</b> #1:DC12V #2~#5: LOUVER SIGNAL OUTPUT
<b>㉑ (21) CN801-SPI</b> #1: GND #2: GND #3: SPI SIGNAL OUTPUT(DC12V)	<b>㉒ TB101-AC POWER</b> #1: POWER(L) #2: POWER(N)	<b>㉓ TE04-COMMUNICATION</b> #1: COM1(F1) #2: COM1(F2) #3: V1(DC12V) #4: V2(GND) #5: COM2(F3) #6: COM2(F4)		

### 5-1-2 Panel PCB

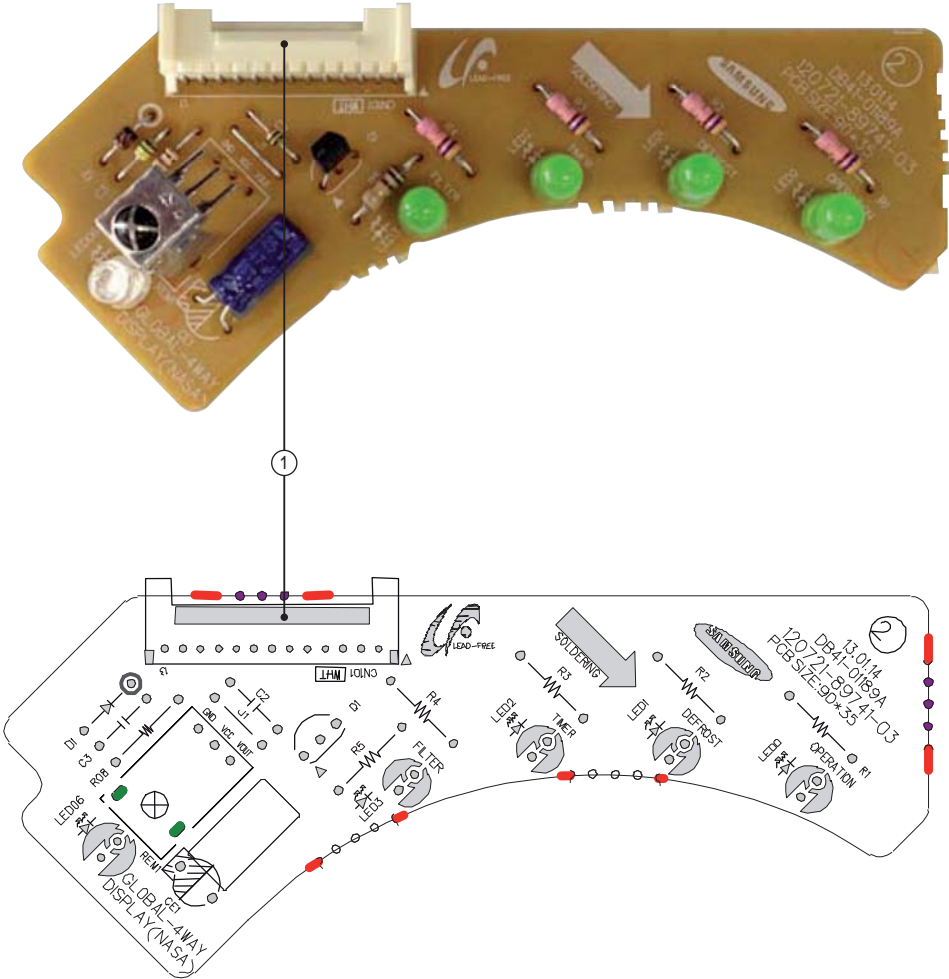

①	<b>CN01-DISPLAY</b>
#1:	DC12V
#2~6:	LED Control Signal
#7:	Not used
#8:	Remocon Signal Out
#9:	Not used
#10:	Remocon Signal In
#12:	Vcc
#13:	Not used

## 5-2 Outdoor Unit

### 5-2-1 Main PCB

#### ■ AC018JXADCH

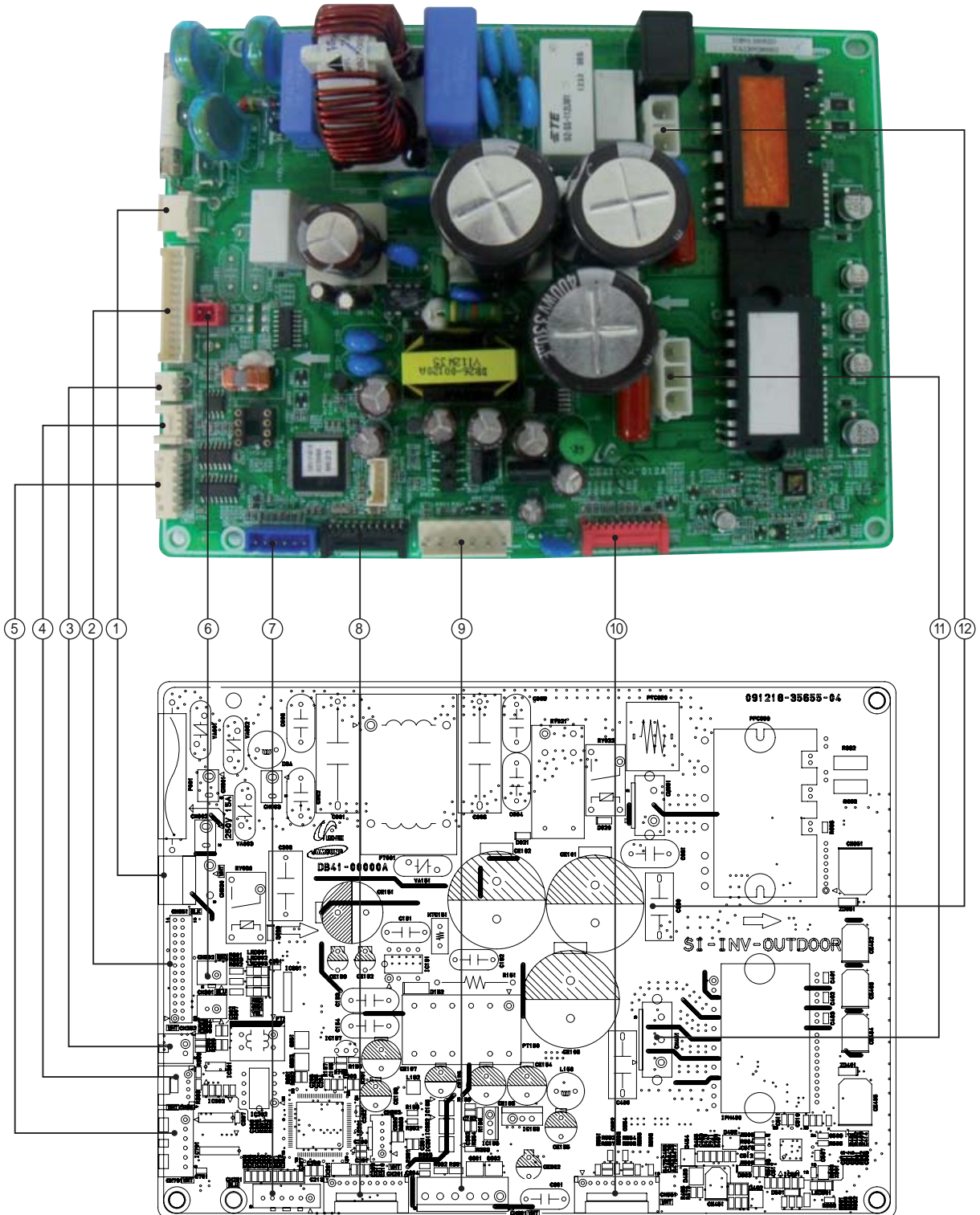

<p>① <b>CN030 : 4WAY VALVE</b> #1~#3 : AC220V</p>	<p>② <b>CN951 : SIGNAL TO SUB PCB</b> #1~#28 : SIGNAL TO SUB PCB</p>	<p>③ <b>CN252 : THERMISTOR</b> #1~#2 : OLP THERMISTOR</p>	<p>④ <b>CN851:S-NET Communication</b> #1 : DC12V #2 : RXD #3 : TXD #4 : GND</p>
<p>⑤ <b>CN701 : EEV</b> #1~#5 : EEV SIGNAL #6 : DC12V</p>	<p>⑥ <b>CN302:Communication(COM1)</b> #1 : COM1(F1) #2 : COM2(F2)</p>	<p>⑦ <b>CN251 : THERMISTOR</b> #1~#2 : OUTDOOR THERMISTOR #3~#4 : DISCHARGE THERMISTOR #5~#6 : COND THERMISTOR</p>	<p>⑧ <b>CN201 : Downloader</b> #1~#10 : Download</p>
<p>⑨ <b>CN901 : BLDC MOTOR</b> #1: DV310V #3: GND #4: DC15V #5: FAN_PWM #6: FAN_Feedback</p>	<p>⑩ <b>CN551: Downloader</b> #1~#10 : Download</p>	<p>⑪ <b>CN451 : COMP POWER</b> #1 : COMP U-Phase #2 : COMP V-Phase #3 : COMP W-Phase</p>	<p>⑫ <b>CN051 : Reactor</b> #1~#2 : Reactor</p>

## 5-2-2 SUB PCB

### ■ AC018JXADCH

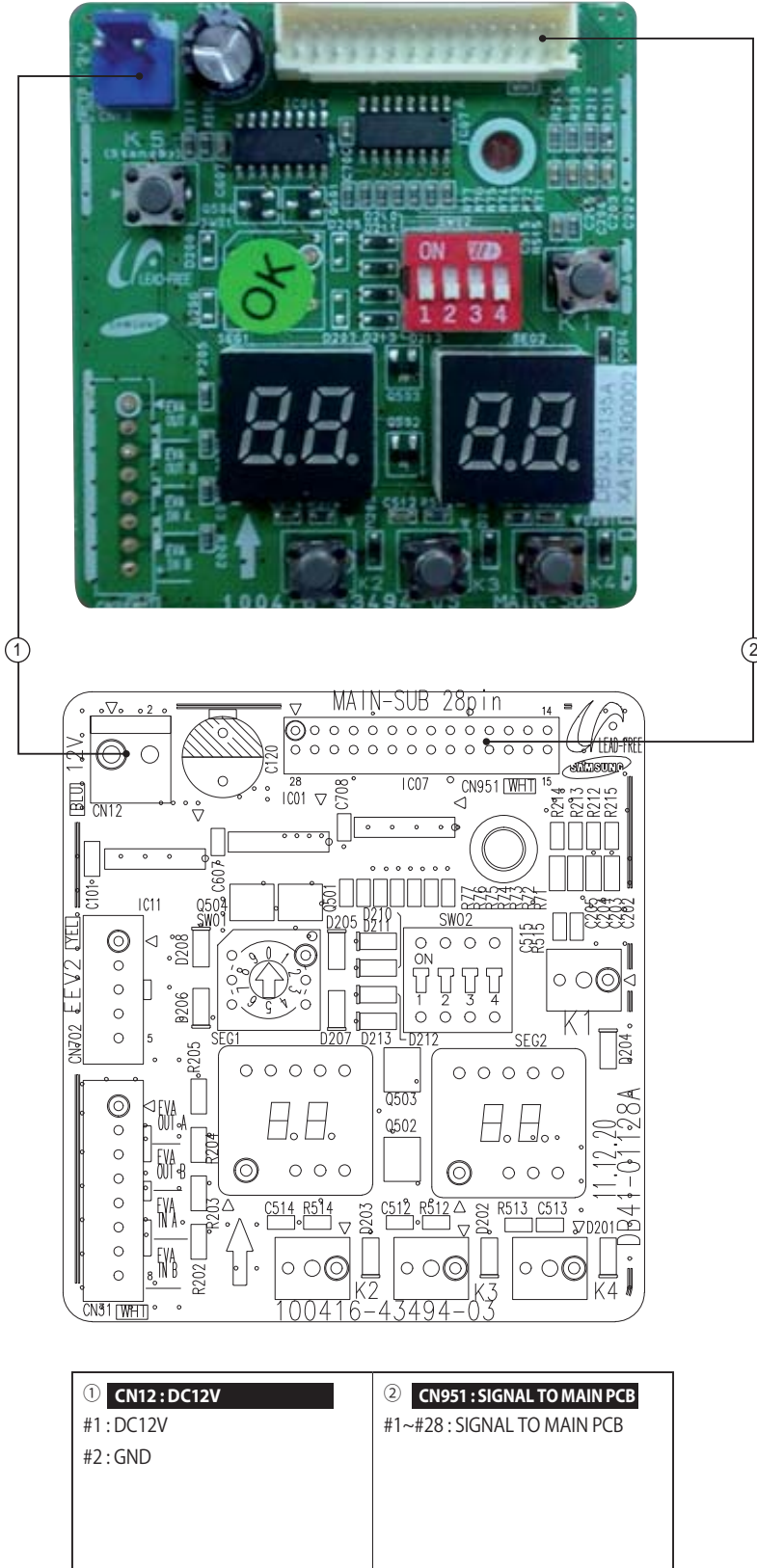

## 5-2-3 MAIN PCB

## ■ AC024JXADCH, AC030JXADCH, AC036JXADCH, AC042JXADCH, AC048JXADCH

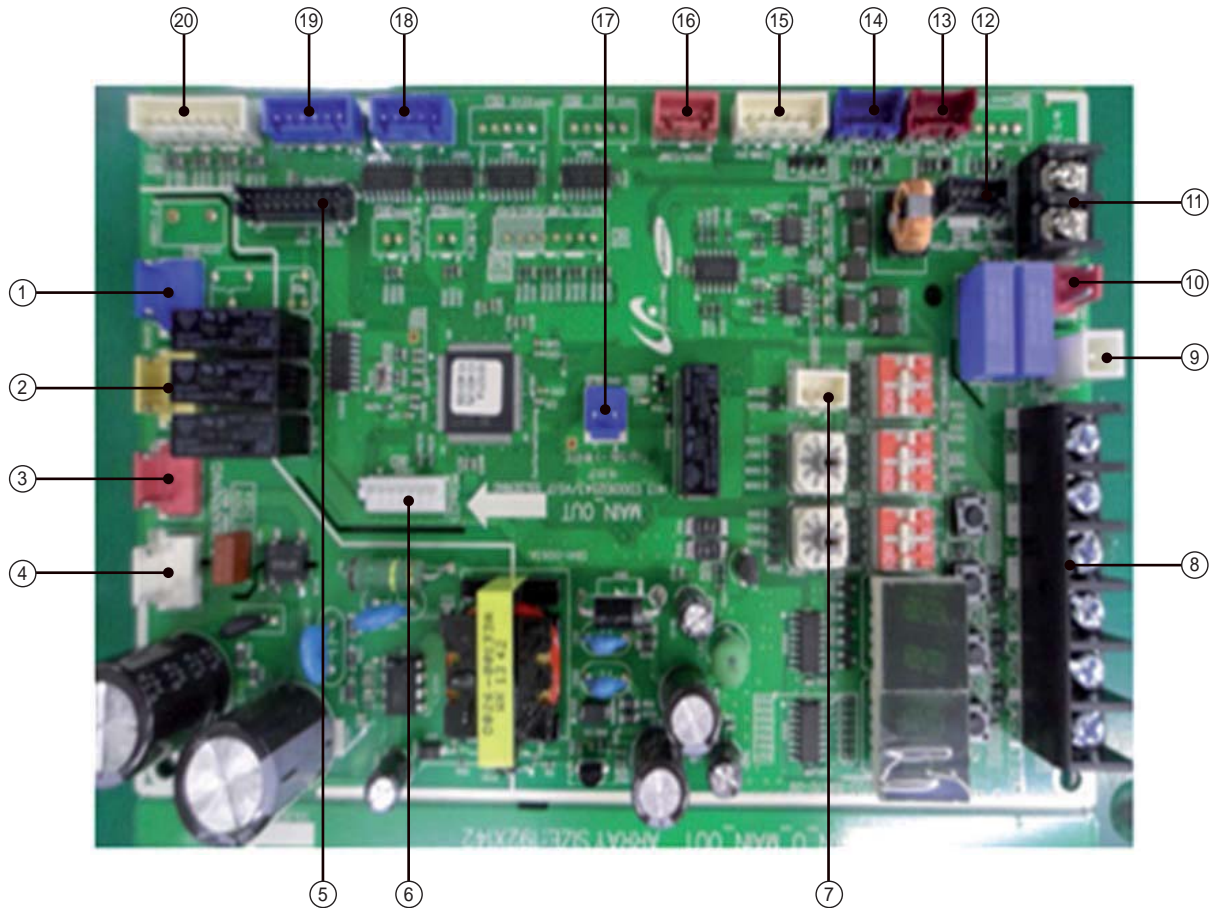

No	Part Code	Local	Function	Description
1	3711-003404	CN703	BASE-HEATER	YW396-03AV BLU
2	3711-003406	CN702	4WAY-1	YW396-03AV YEL
3	3711-003407	CN701	HOTGAS	YW396-03AV RED
4	3711-002023	CN101	POWER	YW396-03AV WHT
5	3711-002001	CN306	DOWNLOAD	YDW200-20P BLK
6	3711-007817	CN806	EEPROM	B7P-MQ WHT
7	3711-000024	CN501	MODE SELECTOR	SMW250-03 WHT
8	DB65-00320A	CN304	DRED	DAPC-2009-6P BLK
9	3711-000744	CN103	EARTH	YDW236-01 WHT
10	3711-000177	CN303	COMM-INDOOR	YW396-02V RED
11	3716-001162	CN003	QUIET S/W	BR-7623-2P BLK
12	3711-005096	CN302	COMM-OPTION	SMW200-05 BLK
13	3711-007069	CN402	HIGH PRESSURE S/W	B04B-XARK-1 RED
14	3711-007325	CN401	LOW PRESSURE S/W	B04B-XARK-1 BLU
15	3711-001038	CN305	COMM INV	SMW250-06 WHT
16	3711-000939	CN801	ERROR/COMP CHECK	SMW250-04 RED
17	3711-000176	CN12	DC12V	YW396-02V BLU
18	3711-000997	CN803	EEV1	SMW250-05 BLU
19	3711-001036	CN802	EEV4	SMW250-06 BLU
20	3711-001084	CN403	OUT TEMP/COND/DISQ/OLP	SMW250-08 WHT



### 5-2-4 INVERTER PCB

#### ■ AC024JXADCH, AC030JXADCH, AC036JXADCH, AC042JXADCH, AC048JXADCH

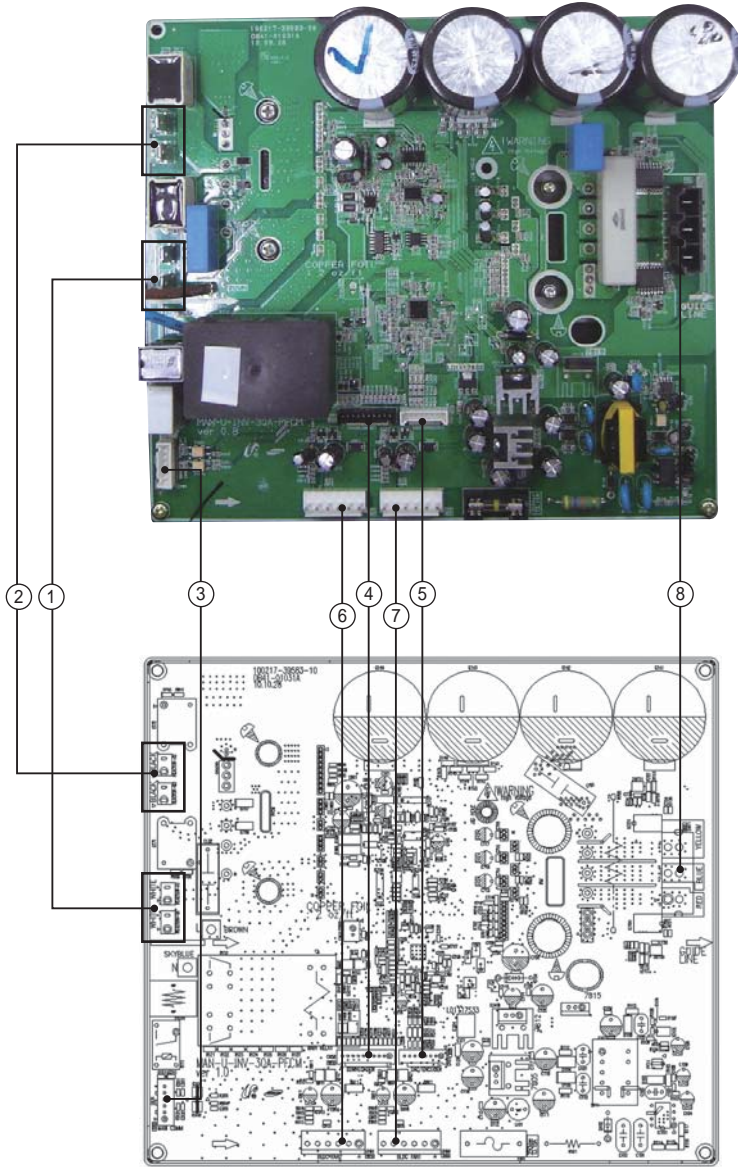

<p>① <b>Reactor-A1/B1</b> #Reactor-A2 : WHT #Reactor-B2 : WHT</p>	<p>② <b>Reactor-A2/B2</b> #Reactor-A2 : BLK #Reactor-B2 : BLK</p>	<p>③ <b>CN50(2PIN/RED)-Communication</b> #1 : RXD, #2 : TXD #3 : GND, #4 : DC 5V #5 : DC 12V, #6 : INV. SMPS signal</p>	<p>④ <b>CN22-Downloader</b> #1 : RXD_ATARO, #2 : TXD_ATARO #3, #8 : N.C, #4~#7 : DATA signal #9 : GND, #10 : DC 5V</p>
<p>⑤ <b>CN21-DAC/ENCODER</b> For S/W engineer debugging</p>	<p>⑥ <b>CN91-FAN2</b> #1 : DC 360V #2 : N.C #3 : GND #4 : DC 15V #5 : FAN RPM #6 : FAN RPM feedback</p>	<p>⑦ <b>CN90-FAN1</b> #1 : DC 360V #2 : N.C #3 : GND #4 : DC 15V #5 : FAN RPM #6 : FAN RPM feedback</p>	<p>⑧ <b>CN71-COMP.</b> #1 : COMP. U-phase(RED) #2 : COMP. V-phase(BLU) #3 : COMP. U-phase(YEL)</p>

### 5-2-5 EMI PCB

#### ■ AC024JXADCH, AC030JXADCH, AC036JXADCH, AC042JXADCH, AC048JXADCH

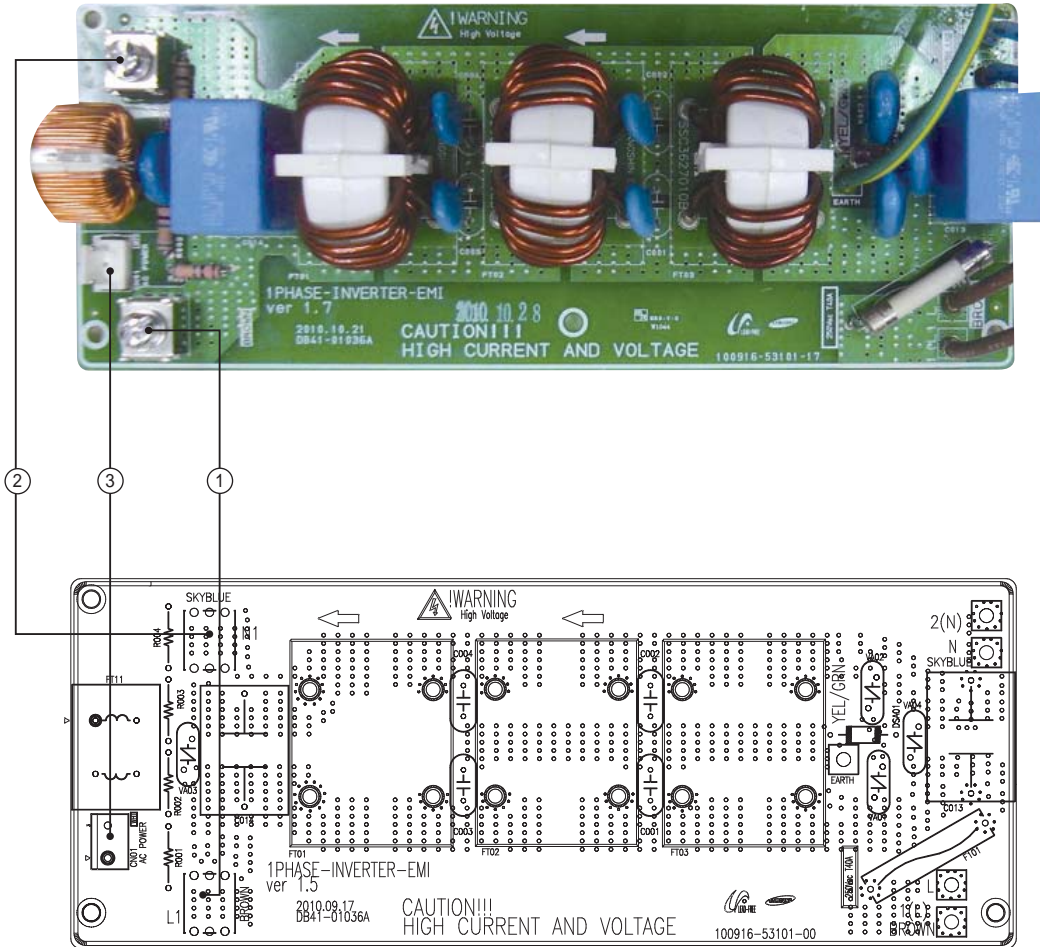

<p>① <b>L1-AC POWER L phase</b> L1 : BRN</p>	<p>② <b>N1-AC POWER N phase</b> N1 : SKY-BLU</p>	<p>③ <b>CN01-AC POWER</b> #1-#3 : AC 220~240V</p>
--	--	---



# 6. Wiring Diagram

## 6-1 Indoor Unit

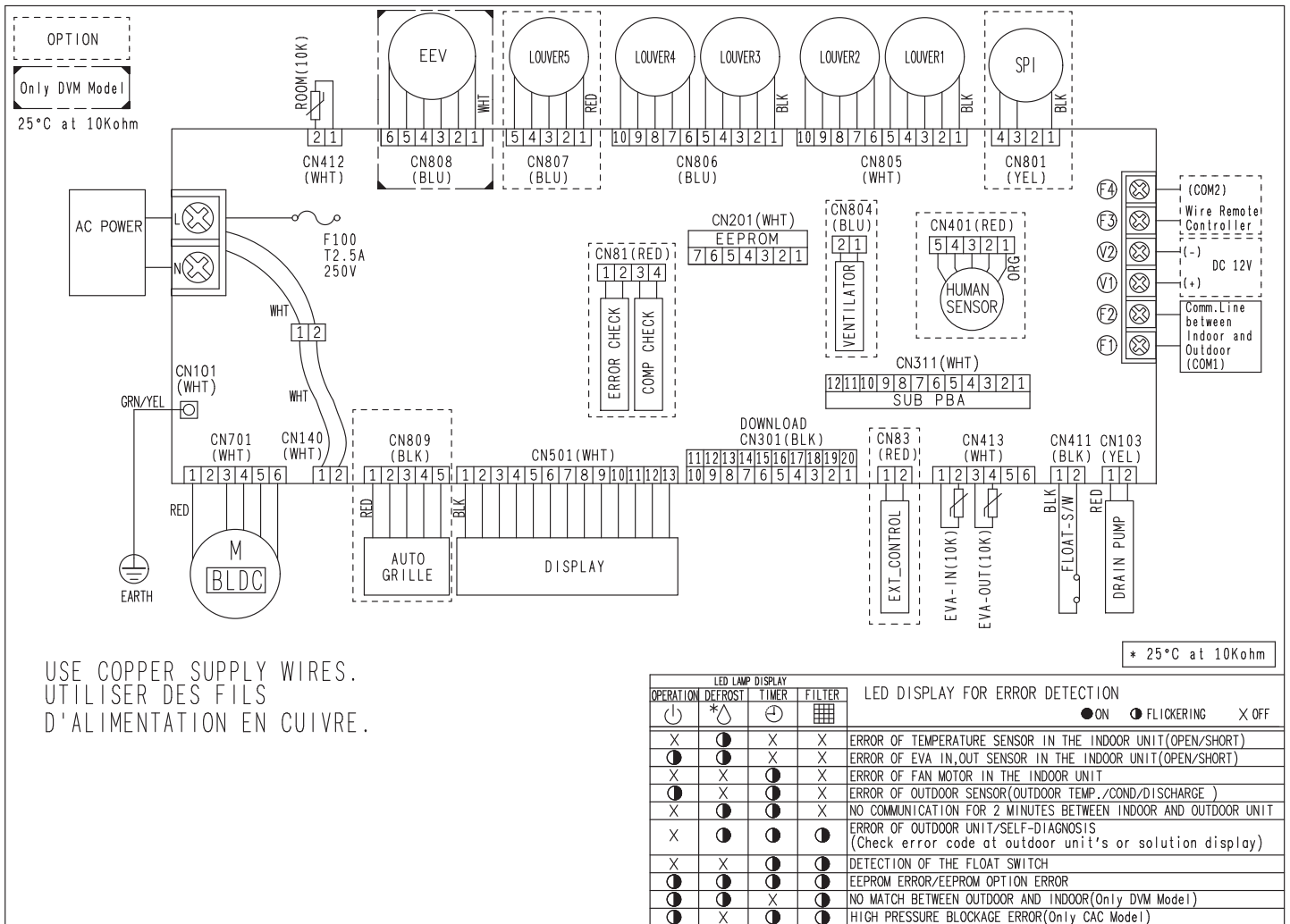

USE COPPER SUPPLY WIRES.  
 UTILISER DES FILS  
 D'ALIMENTATION EN CUIVRE.

This Document can not be used without Samsung's authorization.

## 6-2 Outdoor unit

### ■ AC018JXADCH

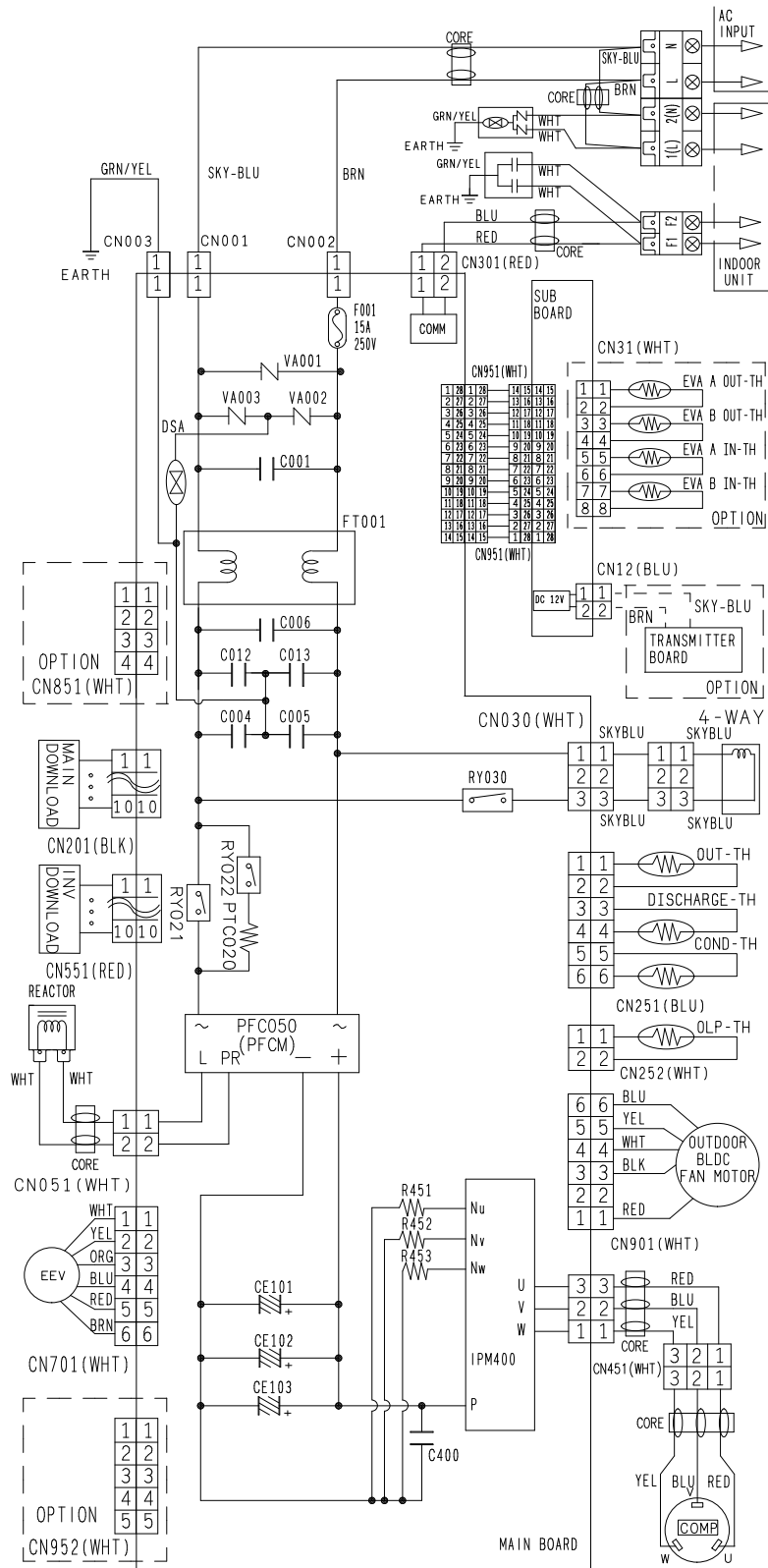

This Document can not be used without Samsung's authorization.

■ AC024JXADCH, AC030JXADCH, AC036JXADCH, AC042JXADCH, AC048JXADCH

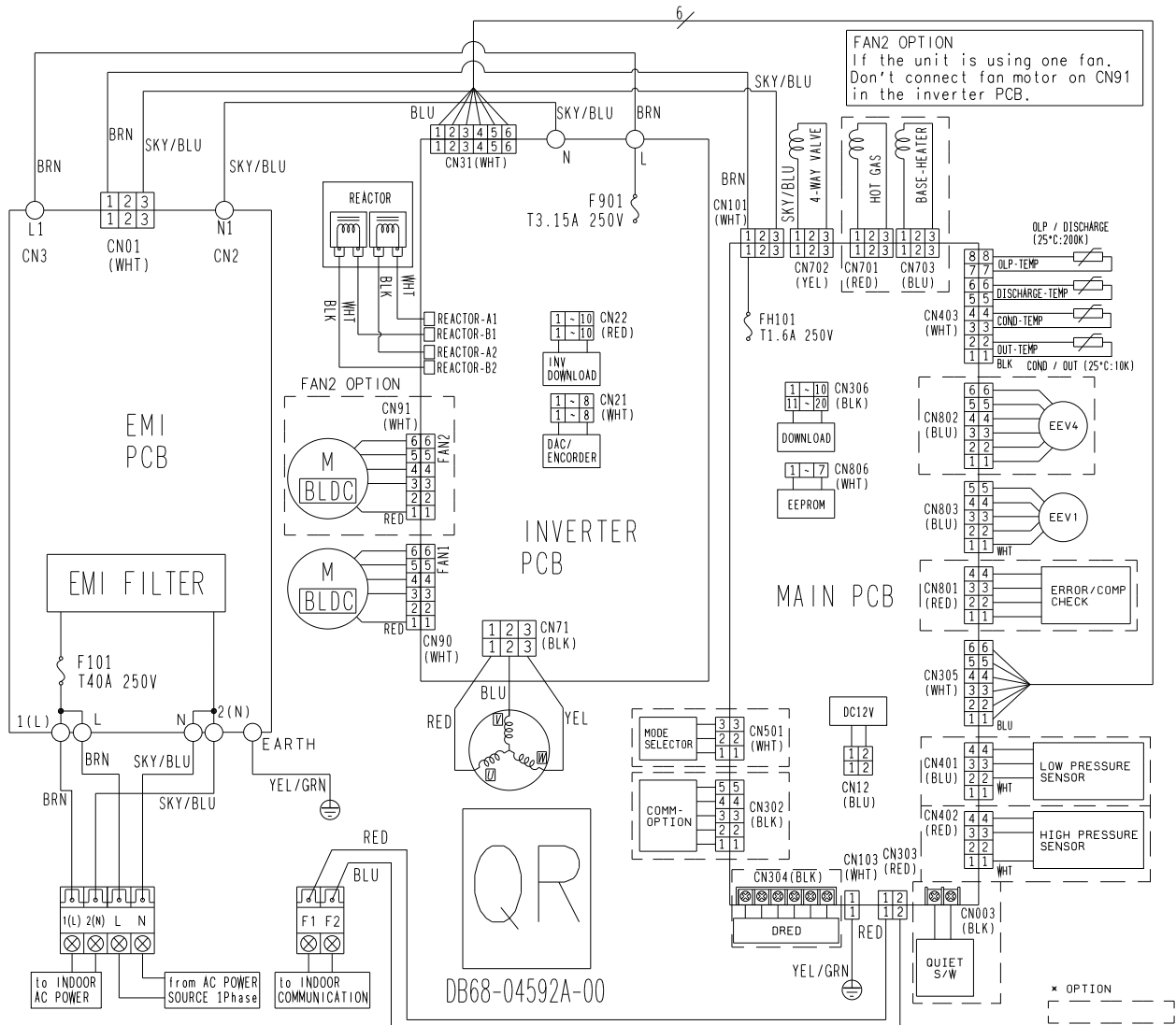

This Document can not be used without Samsung's authorization.

# 7. Reference Sheet

## 7-1 Index for Model Name

### 7-1-1 Indoor Unit

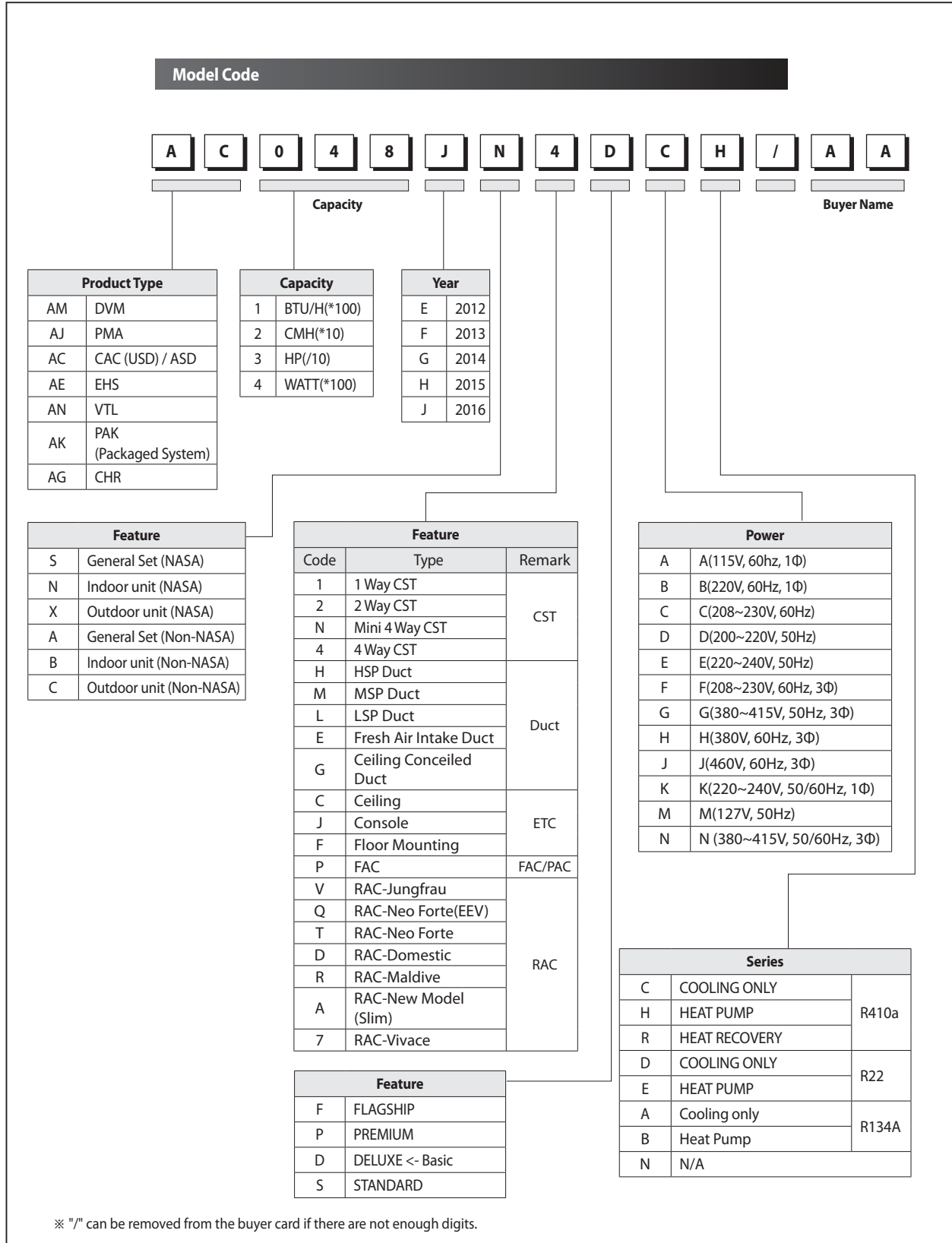

### 7-1-2 Outdoor Unit

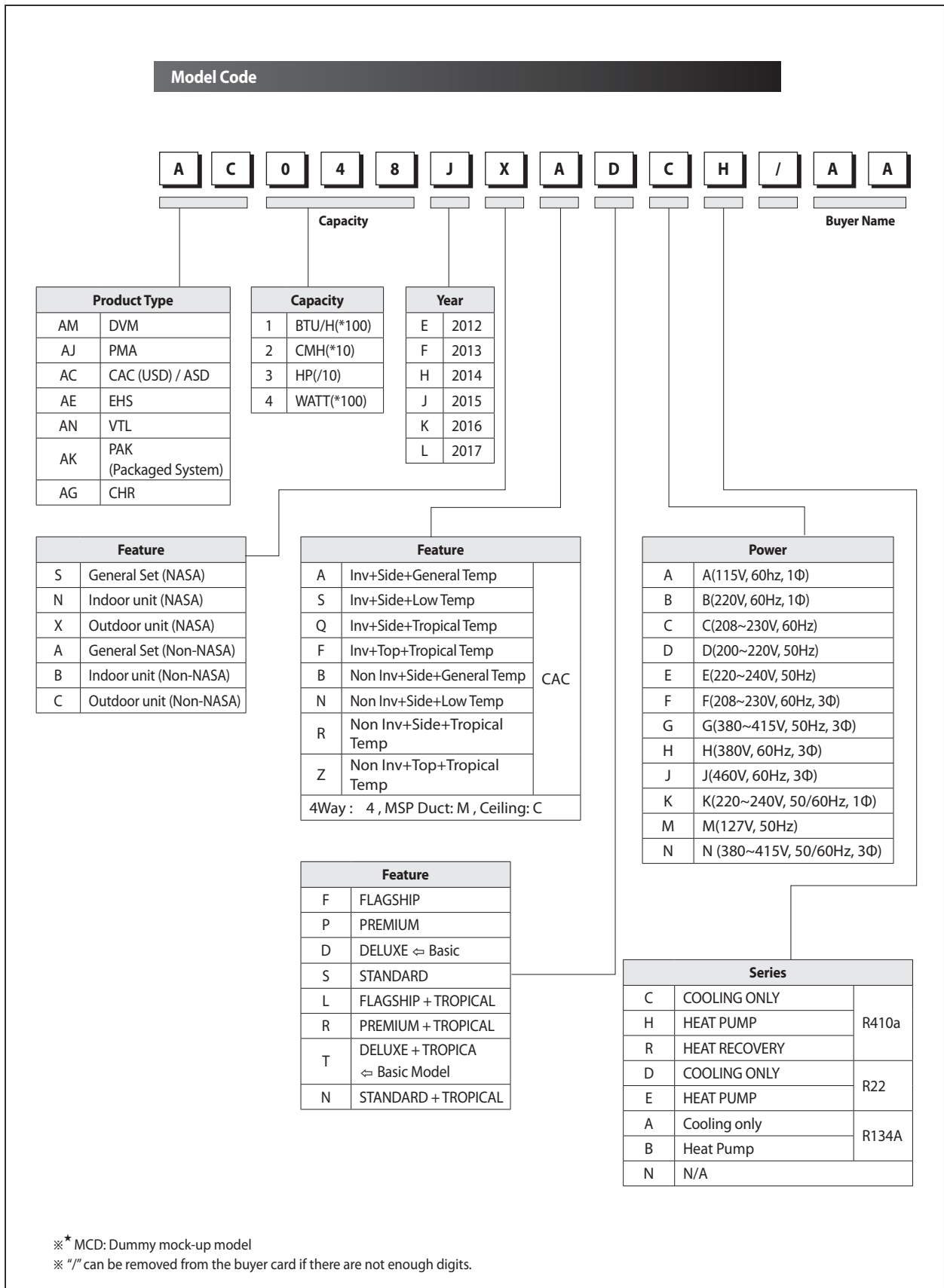

### 7-1-3 Panel

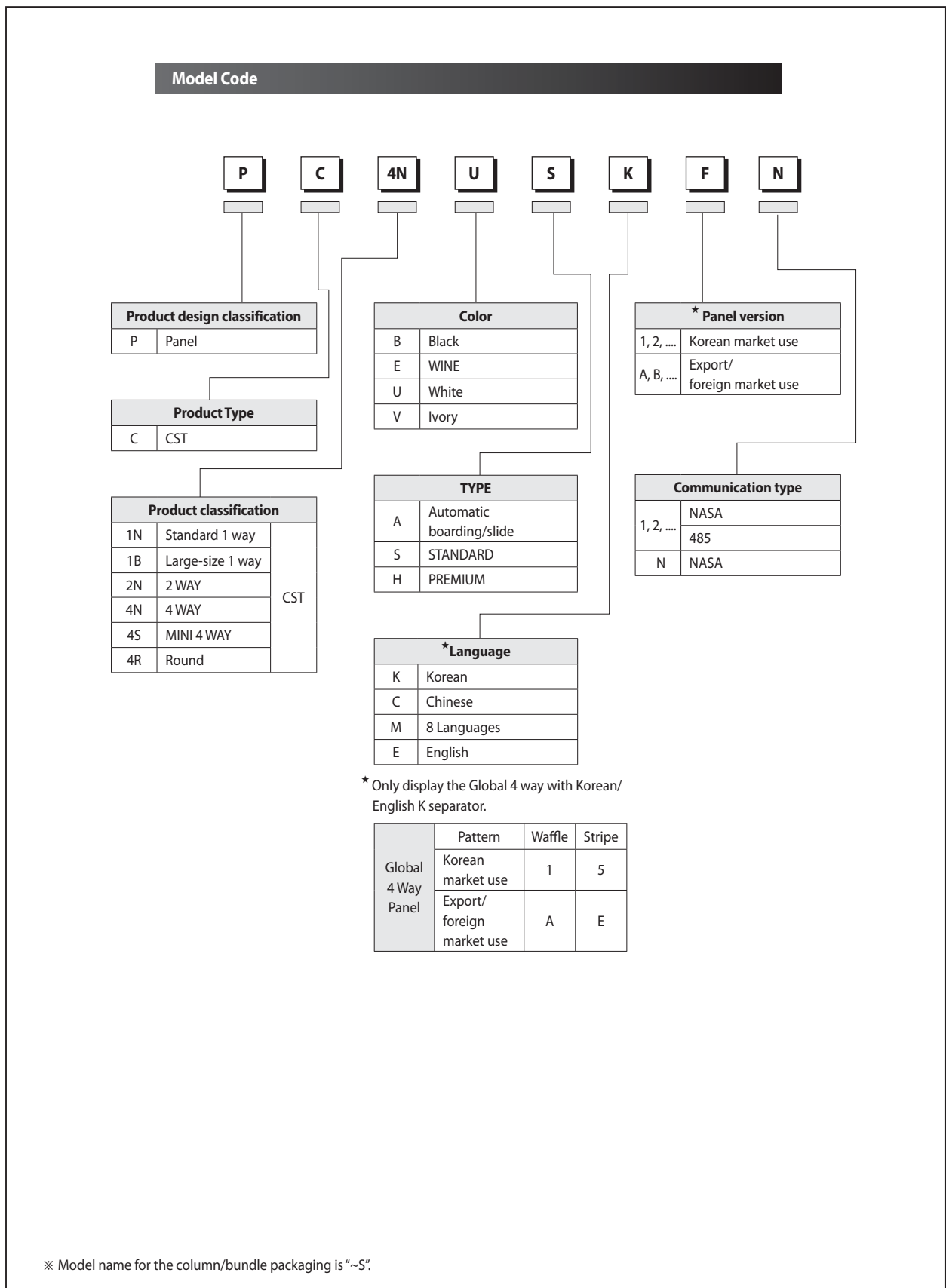

## 7-2 Refrigerating Cycle Diagram

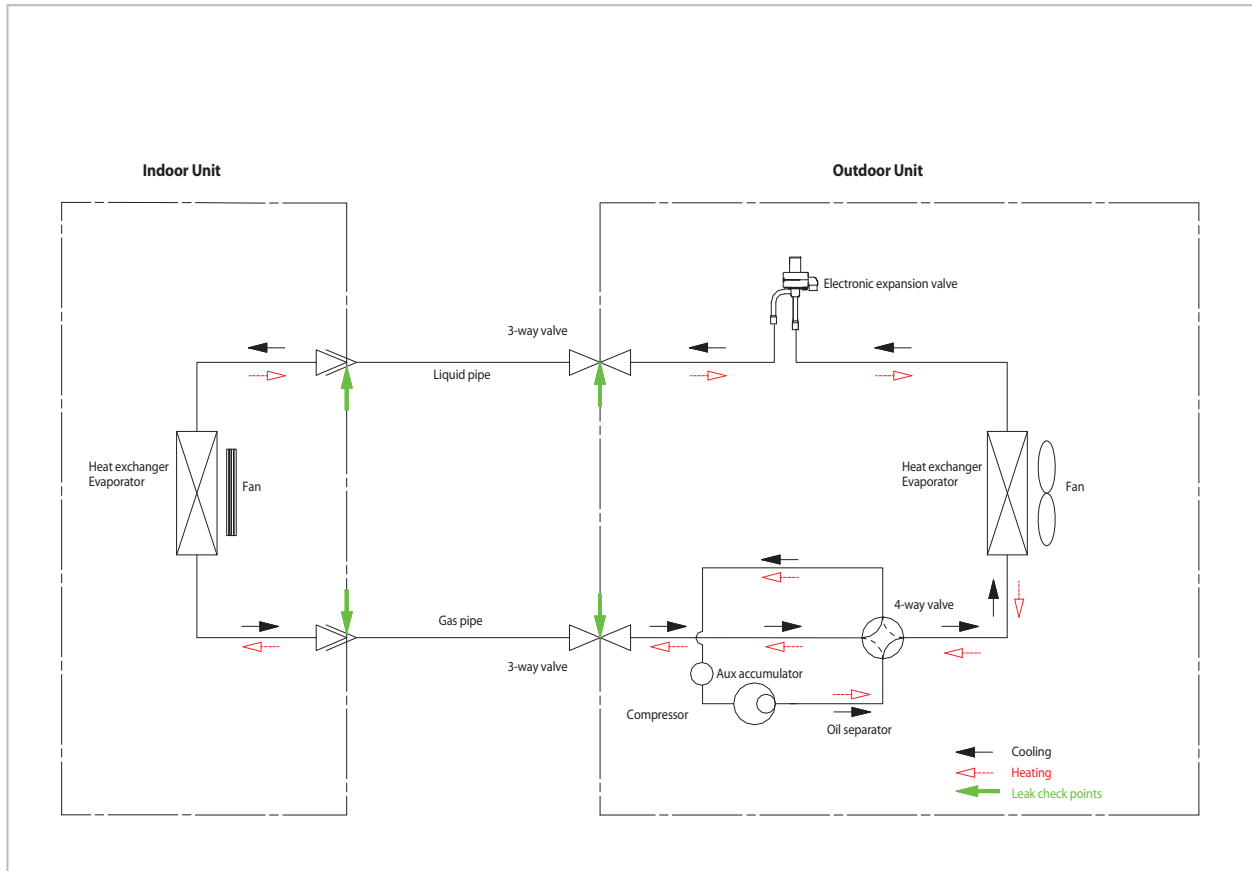

### ■ CONDENSER

High temperature and high pressure gas state coolant discharged from the compressor is converted to a liquid state as it is cooled down by the heat emission in the outdoor condenser unit, and sent to the evaporator.

### ■ COMPRESSOR

Low temperature and low pressure coolant is compressed and sent to the cycling system

### ■ EVAPORATOR

Liquid coolant sucked in through the capillary tubes cools down the room by absorbing the surrounding heat as it evaporates (converting from liquid to gas). (Absorbing heat required for evaporation)

### ■ SERVICE VALVE

You can open the valve by turning the need valve counterclockwise using hex wrench, and it is used for vacuum, gas purging, coolant injection, coolant purging, and indoor-outdoor unit connection.

### ■ ACCUMULATOR

Accumulator prevents the flow of liquid-state coolant into the compressor. (Liquid-state coolant flowing into the compressor will overload the compressor.)



### **GSPN (GLOBAL SERVICE PARTNER NETWORK)**

<b>Area</b>	<b>Web Site</b>
Europe, CIS, Mideast & Africa	<a href="http://gspn1.samsungcsportal.com">gspn1.samsungcsportal.com</a>
Asia	<a href="http://gspn2.samsungcsportal.com">gspn2.samsungcsportal.com</a>
North & Latin America	<a href="http://gspn3.samsungcsportal.com">gspn3.samsungcsportal.com</a>
China	<a href="http://china.samsungportal.com">china.samsungportal.com</a>

This Service Manual is a property of Samsung Electronics Co., Ltd.  
Any unauthorized use of Manual can be punished under applicable  
International and/or domestic law.

© Samsung Electronics Co., Ltd. January. 2015.  
Printed in Korea.  
Code No. AC-00094E\_1