

Job Name/Location:

Tag #:

Date:

For: File Resubmit
 Approval Other _____

PO No.:

Architect:

GC:

Engr:

Mech:

Rep:

(Company)

(Project Manager)

LS360HV2
Standard Single Zone Inverter
 Outdoor Unit (ODU)-LSU360HV2 Indoor Unit (IDU)-LSN360HV2

Performance:

Cooling:

Capacity (Btu/h)	33,000
SEER	16.1
EER	8.2

SEER - Seasonal Energy Efficiency Ratio EER - Energy Efficiency Ratio

Heating:

Capacity (Btu/h)	35,200
HSPF	9.9

HSPF - Heating Seasonal Performance Factor

Cooling Nominal Test Conditions: Indoor: 80°F DB/67°F WB
 Outdoor: 95°F DB/75°F W

Heating Nominal Test Conditions: Indoor: 70°F DB/60°F WB
 Outdoor: 47°F DB/43°F WB

Electrical:

Outdoor Unit:

Power Supply (V ¹ /Hz/Ø)	208-230/60/1
MOP (A)	30
MCA (A)	19
Cooling Rated Amps (A)	15.4
Heating Rated Amps (A)	15.4
Compressor (A)	14.6
Fan Motor (A)	0.75

MOP - Maximum Overcurrent Protection MCA - Minimum Circuit Ampacity

Indoor Unit:

Power Supply (V ¹ /Hz/Ø)	208-230/60/1
Cooling Power Input (kW)	4.03
Heating Power Input (kW)	3.84

Piping:

Liquid Line (in, OD)	3/8
Vapor Line (in, OD)	5/8
Additional Refrigerant (oz/ft)	0.38
Max Pipe Length (ft) ²	98
Max Elevation (ft)	49

Controls Features:

- 24-Hour on/off timer
- Auto changeover
- Auto restart
- Auto sleep mode
- Built-in low ambient standard, down to 14°F (cooling mode)
- Chaos swing
- Condensate Sensor Connection
- Defrost control
- Energy saving
- Evaporator frost control
- Inverter (variable speed compressor)
- Jet cool
- Manual power switch
- Plasma air purifying system
- Self-cleaning indoor coil
- Temperature display on indoor unit
- Ultra-quiet operation

Optional Accessories:

- 7-Day Programmable Controller (Black) - PQRCVSL0
- 7-Day Programmable Controller (White) - PQRCVSLOQW
- Dry Contact for third party thermostat - PQDSBNGCM1
- Low Ambient Wind Baffle (Cooling operation to 0°F) - ZLABGP02A
- PI-485 - PMNFP14A0

For continual product development, LG reserves the right to change specifications without notice.

LG Electronics U.S.A., Inc., Englewood Cliffs, NJ. All rights reserved. "LG Life's Good" is a registered trademark of LG Corp. /www.lghvac.com



PQWRHSFO

Operating Range:

Outdoor Unit:

Cooling (°F DB)	14-118
Heating (°F DB)	5-75

Indoor Unit:

Cooling (°F DB)	64-90
Heating (°F DB)	61-86

Unit Data:

Refrigerant Type	R410A
Refrigerant Control	EEV
Refrigerant Charge (lbs)	4.41
ODU Sound Pressure Max (±3 dB(A)) ³	55
IDU Sound Pressure (H/M/L) (±3 dB(A)) ³	49/44/39
ODU Net Weight (lbs)	142
ODU Shipping Weight (lbs)	153
IDU Net Weight	34
IDU Shipping Weight (lbs)	45
Heat Exchanger Coating	GoldFin™
Communication Cable (No x AWG) ⁴	4 x 18

Fan:

ODU Type	Propeller
IDU Type	Cross Flow
Fan Speeds (Fan/Cooling/Heating)	3/4/3
Quantity (ODU + IDU)	1 + 1
Motor/Drive	Brushless Digitally Controlled/Direct
ODU Max Air Flow Rate (CFM)	2,119
IDU Max Air Flow H/M/L (CFM)	740/670/450
Dehumidification (pts/hr)	10.6

Notes:

1. Acceptable operating voltage: 187V - 253V.
2. Piping lengths are equivalent.
3. Sound Pressure levels are tested in an anechoic chamber under ISO Standard 1996.
4. All communication cable to be minimum 18 AWG, 2-conductor, stranded, shielded and must comply with applicable local and national code.
5. See Engineering Manual for sensible and latent capacities.
6. Power wiring cable size must comply with the applicable local and national code.
7. This unit comes with a dry helium charge.
8. This data is rated 0 ft above sea level, with 24.6 ft of refrigerant line and a 0 ft level difference between outdoor and indoor units.
9. Must follow installation instructions in the applicable LG installation manual.

Standard Features:

- Limited Seven Year Compressor Warranty
- Limited Five Year Functional Parts Warranty



Outdoor Unit (ODU)-LSU360HV2
Standard Single Zone Inverter



Tag #:

Date:

PO No.:

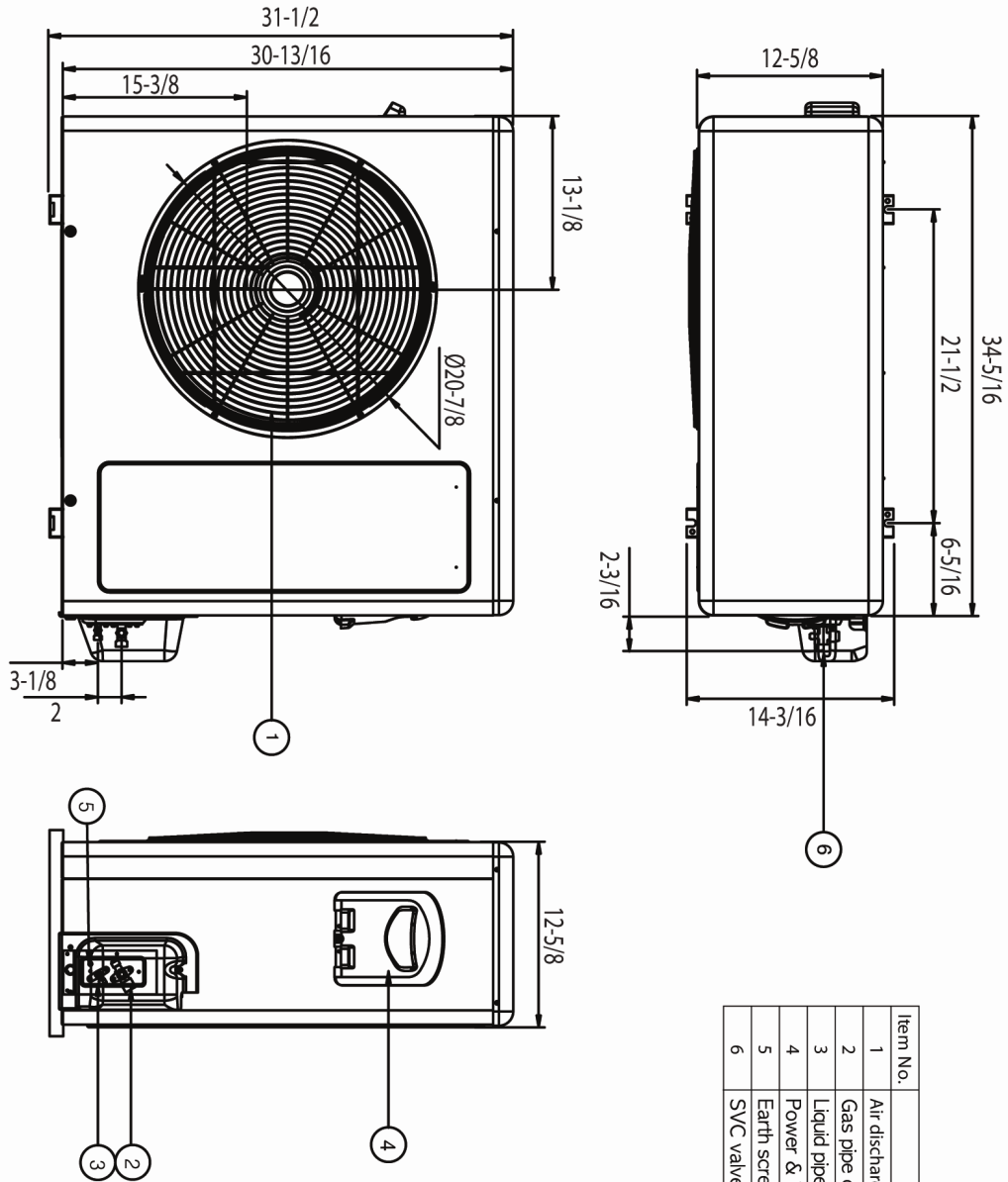

Unit: inch

Item No.	Part Name	Remarks
1	Air discharge grille	
2	Gas pipe connection	
3	Liquid pipe connection	
4	Power & Transmission connection	
5	Earth screw	
6	SVC valve cover	

Indoor Unit (IDU)-LSN360HV2
Standard Single Zone Inverter



Tag #:

Date:

PO No.:

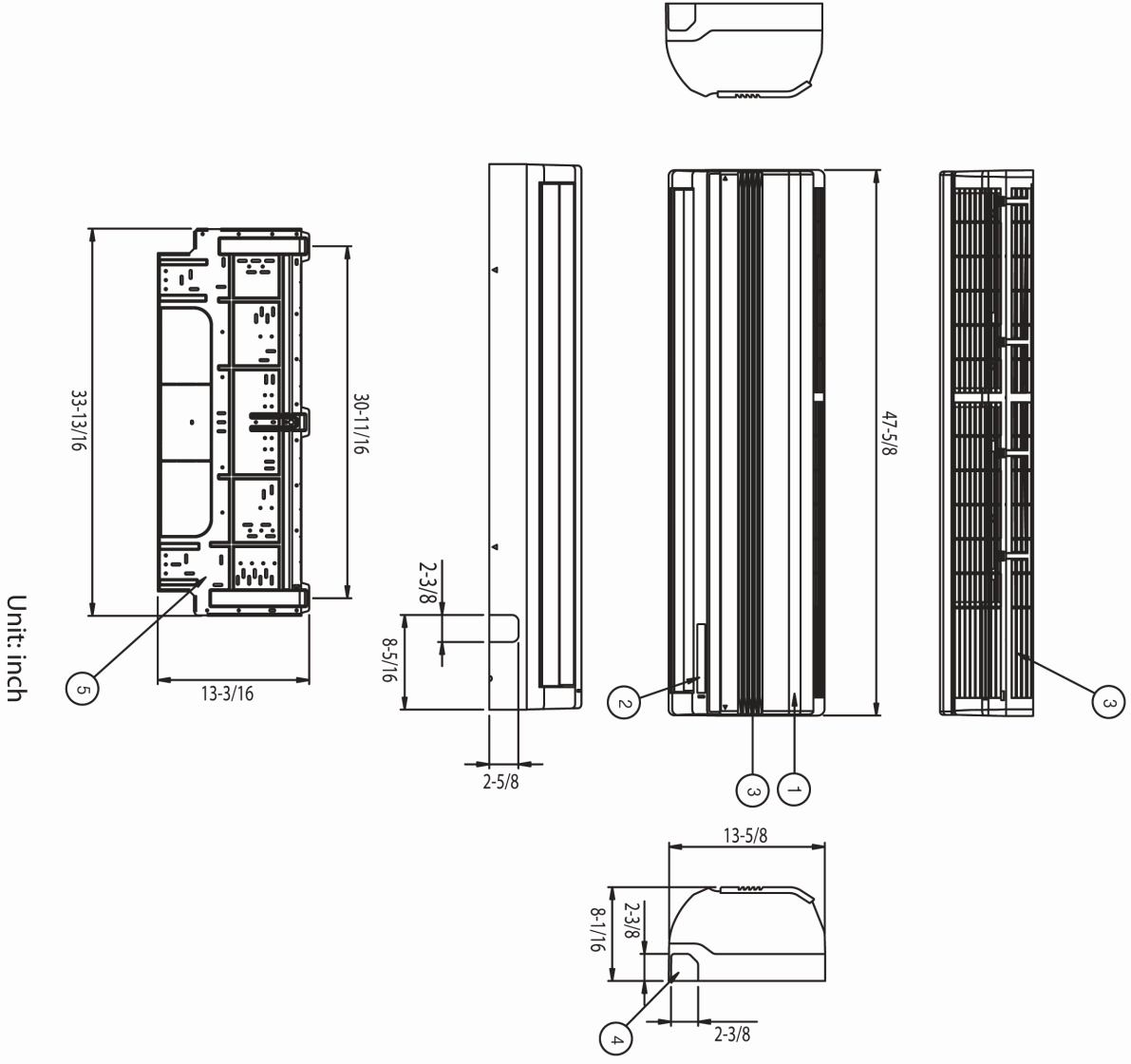

Unit: inch

Item No.	Part Name	Remarks
1	Front panel	
2	Display & signal receiver	
3	Air suction grille	
4	Knockout hole	For pipe and cable
5	Installation plate	